

cdmaOne Guide

Agilent Technologies PSA Series and VSA E4406A

Option BAC

This manual provides documentation for the following instruments:

**Transmitter Tester:
E4406A**

**Spectrum Analyzers:
E4440A (3 Hz - 26.5 GHz)
E4443A (3 Hz - 6.7 GHz)
E4445A (3 Hz - 13.2 GHz)
E4446A (3 Hz - 44.0 GHz)
E4447A (3 Hz - 42.98 GHz)
E4448A (3 Hz - 50.0 GHz)**



**Manufacturing Part Number: E4406-90309
Supersedes E4440-90259**

Printed in USA

May 2007

© Copyright 1999 - 2007 Agilent Technologies, Inc.

The information contained in this document is subject to change without notice.

Agilent Technologies makes no warranty of any kind with regard to this material, including but not limited to, the implied warranties of merchantability and fitness for a particular purpose. Agilent Technologies shall not be liable for errors contained herein or for incidental or consequential damages in connection with the furnishing, performance, or use of this material.

1. Introduction	
What Does the Agilent PSA Series or VSA E4406A Do?	20
Installing Optional Measurement Personalities	21
2. Making Measurements	
cdmaOne Measurements	32
Instrument Front Panel Highlights	33
Setting up and Making a Measurement	36
Adjacent Channel Power Ratio (ACPR) Measurements	38
Channel Power Measurements	44
Modulation Accuracy (Composite Rho) Measurements	47
Code Domain Measurements (Base Station)	51
Spur Close Measurements	55
Spectrum (Frequency Domain) Measurements	62
Waveform (Time Domain) Measurements	77
Using Basic Mode	89
If You Have a Problem	90
3. Key Reference	
Front Panel Keys	92
cdmaOne Measurement Keys	100
4. Programming Commands	
SCPI Command Subsystems	162
Programming Command Compatibility	
Across Model Numbers and Across Modes	163
CALCulate Subsystem	168
CONFigure Subsystem	193
DISPlay Subsystem	194
FETCh Subsystem	204
FORMat Subsystem	205
INITiate Subsystem	207
INSTrument Subsystem	209
MEASure Group of Commands	213
READ Subsystem	264
SENSe Subsystem	265
TRIGger Subsystem	334
5. Concepts	
What Is the cdmaOne (IS-95) Communication System?	342
Channel Power Measurement Concepts	344
Modulation Accuracy (Rho) Measurement Concepts	345
Code Domain Measurement Concepts	
(Base Station Only)	346
Spur Close Measurement Concepts	348
Spectrum (Frequency Domain) Measurement Concepts	351
Waveform (Time Domain) Measurement Concepts	352

Contents

Adjacent Channel Power Ratio (ACPR) Measurement Concepts	353
Other Sources of Measurement Information	355
6. Menu Maps	
cdmaOne Measurement Key Flow	358

List of Commands

:CALCulate:ACP:LIMit:STATe OFF ON 0 1	168
:CALCulate:ACP:LIMit:STATe?	168
:CALCulate:CLIMits:FAIL?	169
:CALCulate:CLIMits:FAIL?	217
:CALCulate:DATA<n>:COMPRESS? BLOCK CFIT MAXimum MINimum MEAN DMEan RMS RMSCubed SAMPLE SDEVIation PPHase [,<soffset>[,<length>[,<roffset>[,<rlimit>]]]].	169
:CALCulate:DATA<n>:PEAKs? <threshold>,<excursion>[,AMPLitude FREQuency TIME] ...	179
:CALCulate:DATA[n]?	169
:CALCulate:<measurement>:MARKer:AOFF	184
:CALCulate:<measurement>:MARKer[1] 2 3 4:FUNCTion:RESult?	184
:CALCulate:<measurement>:MARKer[1] 2 3 4:MAXimum	184
:CALCulate:<measurement>:MARKer[1] 2 3 4:MINimum	185
:CALCulate:<measurement>:MARKer[1] 2 3 4:MODE POSition DELTA	185
:CALCulate:<measurement>:MARKer[1] 2 3 4:MODE POSition DELTA RMSDegree RMSRadian RFM RMSJitter OFF.	185
:CALCulate:<measurement>:MARKer[1] 2 3 4:MODE?	185
:CALCulate:<measurement>:MARKer[1] 2 3 4:TRACe <trace_name>	186
:CALCulate:<measurement>:MARKer[1] 2 3 4:TRACe?	186
:CALCulate:<measurement>:MARKer[1] 2 3 4:X <param>	190
:CALCulate:<measurement>:MARKer[1] 2 3 4:X:POSition <integer>	191
:CALCulate:<measurement>:MARKer[1] 2 3 4:X:POSition?	191
:CALCulate:<measurement>:MARKer[1] 2 3 4:X?	190
:CALCulate:<measurement>:MARKer[1] 2 3 4:Y?	191
:CALCulate:<measurement>:MARKer[1] 2 3 4[:STATe] OFF ON 0 1	186
:CALCulate:<measurement>:MARKer[1] 2 3 4[:STATe]?	186
:CONFigure:ACP	218
:CONFigure:CDPower	226
:CONFigure:CHPower	242
:CONFigure:CSPur.	243
:CONFigure:RHO	244
:CONFigure:SPECTrum	259

List of Commands

:CONFigure:WAVeform	262
:CONFigure:<measurement>	193
:CONFigure?	193
:CONFigure?	217
:DISPlay:ACP:VIEW BGRaph SPECTrum	194
:DISPlay:ACP:VIEW?	194
:DISPlay:FORMat:TILE	194
:DISPlay:FORMat:ZOOM	195
:DISPlay:SPECTrum[n]:WINDow[m]:TRACe:Y[:SCALe]:PDIVision <power>	195
:DISPlay:SPECTrum[n]:WINDow[m]:TRACe:Y[:SCALe]:PDIVision?	195
:DISPlay:SPECTrum[n]:WINDow[m]:TRACe:Y[:SCALe]:RLEVel <power>	196
:DISPlay:SPECTrum[n]:WINDow[m]:TRACe:Y[:SCALe]:RLEVel?	196
:DISPlay:TRACe[n][:STATe] OFF ON 0 1	197
:DISPlay:TRACe[n][:STATe]?	197
:DISPlay:WAVeform[n]:WINDow[m]:TRACe:Y[:SCALe]:PDIVision <power>	202
:DISPlay:WAVeform[n]:WINDow[m]:TRACe:Y[:SCALe]:PDIVision?	202
:DISPlay:WAVeform[n]:WINDow[m]:TRACe:Y[:SCALe]:RLEVel <power>	203
:DISPlay:WAVeform[n]:WINDow[m]:TRACe:Y[:SCALe]:RLEVel?	203
:FETCh:ACP[n]?	218
:FETCh:CDPower[n]?	226
:FETCh:CHPower[n]?	242
:FETCh:CSPur[n]?	243
:FETCh:RHO[n]?	244
:FETCh:SPECTrum[n]?	259
:FETCh:WAVeform[n]?	262
:FETCh:<measurement>[n]?	204
:FORMat:BORDER NORMal SWAPped	205
:FORMat:BORDER?	205
:FORMat[:DATA] ASCii REAL,32 REAL,64	205
:FORMat[:DATA]?	205
:FORMat[:TRACe][:DATA] ASCii INTeger,16 INTeger,32 REAL,32 REAL,64 UINTegeR,16	205

List of Commands

:FORMat[:TRACe][:DATA] ASCii REAL[,32]	205
:FORMat[:TRACe][:DATA]?	205
:FORMat[:TRACe][:DATA]?	205
:INITiate:ACP	218
:INITiate:CDPower	226
:INITiate:CHPower	242
:INITiate:CONTinuous OFF ON 0 1	207
:INITiate:CONTinuous?	207
:INITiate:CSPur	243
:INITiate:REStart	208
:INITiate:RHO	244
:INITiate:SPECtrum	259
:INITiate:WAVEform	262
:INITiate:<measurement>	207
:INITiate[:IMMEDIATE]	208
:INSTrument:CATalog?	209
:INSTrument:CATalog[:FULL]?	209
:INSTrument:NSElect <integer>	209
:INSTrument:NSElect?	209
:INSTrument[:SElect] BASIC SERVICE CDMA CDMA2K GSM EDGE GSM IDEN WIDEN NADC PDC WCDMA CDMA1XEV	210
:INSTrument[:SElect] SA PNOISE BASIC CDMA CDMA2K EDGE GSM NADC PDC WCDMA CDMA1XEV NFIGURE WLAN TDSCDMA TDDEMOD MRECEIVE EMC DEMODULATION	211
:INSTrument[:SElect]?	211
:MEASure:ACP[n]?	218
:MEASure:CDPower[n]?	226
:MEASure:CHPower[n]?	242
:MEASure:CSPur[n]?	243
:MEASure:RHO[n]?	244
:MEASure:SPECtrum[n]?	259
:MEASure:WAVEform[n]?	262

List of Commands

:READ:ACP[n]?	218
:READ:CDPower[n]?	226
:READ:CHPower[n]?	242
:READ:CSPur[n]?	243
:READ:RHO[n]?	244
:READ:SPECTrum[n]?	259
:READ:WAVeform[n]?	262
:READ:<measurement>[n]?	264
:TRIGger[:SEQuence]:AUTO:STATe OFF ON 0 1	334
:TRIGger[:SEQuence]:AUTO:STATe?	334
:TRIGger[:SEQuence]:AUTO[:TIME] <time>	334
:TRIGger[:SEQuence]:AUTO[:TIME]?	334
:TRIGger[:SEQuence]:EXTernal[1] 2:DELay <time>	335
:TRIGger[:SEQuence]:EXTernal[1] 2:DELay?	335
:TRIGger[:SEQuence]:EXTernal[1] 2:LEVel <voltage>	335
:TRIGger[:SEQuence]:EXTernal[1] 2:LEVel?	335
:TRIGger[:SEQuence]:EXTernal[1] 2:SLOPe NEGative POSitive	335
:TRIGger[:SEQuence]:EXTernal[1] 2:SLOPe?	336
:TRIGger[:SEQuence]:FRAMe:ADJust <time>	336
:TRIGger[:SEQuence]:FRAMe:PERiod <time>	336
:TRIGger[:SEQuence]:FRAMe:PERiod?	336
:TRIGger[:SEQuence]:FRAMe:SYNC EXTFront EXTRear OFF	337
:TRIGger[:SEQuence]:FRAMe:SYNC:OFFSet <time>	337
:TRIGger[:SEQuence]:FRAMe:SYNC:OFFSet?	337
:TRIGger[:SEQuence]:FRAMe:SYNC?	337
:TRIGger[:SEQuence]:HOLDoff <time>	338
:TRIGger[:SEQuence]:HOLDoff?	338
:TRIGger[:SEQuence]:IF:DELay <time>	338
:TRIGger[:SEQuence]:IF:DELay?	338
:TRIGger[:SEQuence]:IF:LEVel <ampl>	338
:TRIGger[:SEQuence]:IF:LEVel?	338

List of Commands

:TRIGger[:SEQuence]:IF:SLOPe NEGative POSitive	339
:TRIGger[:SEQuence]:IF:SLOPe?	339
:TRIGger[:SEQuence]:RFBurst:DELay <time>	339
:TRIGger[:SEQuence]:RFBurst:DELay?	339
:TRIGger[:SEQuence]:RFBurst:LEVel <rel_power>	339
:TRIGger[:SEQuence]:RFBurst:LEVel?	339
:TRIGger[:SEQuence]:RFBurst:SLOPe NEGative POSitive	340
:TRIGger[:SEQuence]:RFBurst:SLOPe?	340
[:SENSe]:ACP:AVERAge:COUNt <integer>	265
[:SENSe]:ACP:AVERAge:COUNt?	265
[:SENSe]:ACP:AVERAge:TCONtrol EXPOnential REPeat	266
[:SENSe]:ACP:AVERAge:TCONtrol?	266
[:SENSe]:ACP:AVERAge:TYPE MAXimum RMS	266
[:SENSe]:ACP:AVERAge:TYPE?	266
[:SENSe]:ACP:AVERAge[:STATe] OFF ON 0 1	265
[:SENSe]:ACP:AVERAge[:STATe]?	265
[:SENSe]:ACP:BANDwidth[n] BWIDth[n]:INTegration <freq>	267
[:SENSe]:ACP:BANDwidth[n] BWIDth[n]:INTegration?	267
[:SENSe]:ACP:BANDwidth[n] BWIDth[n]:INTegration[m] <freq>	267
[:SENSe]:ACP:BANDwidth[n] BWIDth[n]:INTegration[m]?	267
[:SENSe]:ACP:BANDwidth BWIDth:INTegration <freq>	267
[:SENSe]:ACP:BANDwidth BWIDth:INTegration?	267
[:SENSe]:ACP:DYNAmic[n]:RANGe[m] HIGH NORMAl MODified	268
[:SENSe]:ACP:DYNAmic[n]:RANGe[m]?	268
[:SENSe]:ACP:FFTSegment <integer>	268
[:SENSe]:ACP:FFTSegment:AUTO OFF ON 0 1	269
[:SENSe]:ACP:FFTSegment:AUTO?	269
[:SENSe]:ACP:FFTSegment?	269
[:SENSe]:ACP:FREQuency:SPAN?	269
[:SENSe]:ACP:OFFSet:ABSolute <power>	270
[:SENSe]:ACP:OFFSet:ABSolute?	270

List of Commands

[:SENSe]:ACP:OFFSet:BANDwidth BWIDth <res_bw>	271
[:SENSe]:ACP:OFFSet:BANDwidth BWIDth?	271
[:SENSe]:ACP:OFFSet:LIST:ABSolute <power>,<power>,<power>,<power>,<power>	270
[:SENSe]:ACP:OFFSet:LIST:ABSolute?	270
[:SENSe]:ACP:OFFSet:LIST:AVERAge:TYPE MAXimum RMS	271
[:SENSe]:ACP:OFFSet:LIST:AVERAge:TYPE?	271
[:SENSe]:ACP:OFFSet:LIST:BANDwidth BWIDth <res_bw>,<res_bw>,<res_bw>,<res_bw>,<res_bw>	272
[:SENSe]:ACP:OFFSet:LIST:BANDwidth BWIDth?	272
[:SENSe]:ACP:OFFSet:LIST:FFTSegment <integer>,<integer>,<integer>,<integer>,<integer> ..	273
[:SENSe]:ACP:OFFSet:LIST:FFTSegment:AUTO OFF ON 0 1, OFF ON 0 1, OFF ON 0 1, OFF ON 0 1, OFF ON 0 1	273
[:SENSe]:ACP:OFFSet:LIST:FFTSegment:AUTO?	274
[:SENSe]:ACP:OFFSet:LIST:FFTSegment?	273
[:SENSe]:ACP:OFFSet:LIST:POINts <integer>,<integer>,<integer>,<integer>,<integer>	275
[:SENSe]:ACP:OFFSet:LIST:POINts:AUTO OFF ON 0 1, OFF ON 0 1, OFF ON 0 1, OFF ON 0 1, OFF ON 0 1	276
[:SENSe]:ACP:OFFSet:LIST:POINts:AUTO?	276
[:SENSe]:ACP:OFFSet:LIST:POINts?	275
[:SENSe]:ACP:OFFSet:LIST:RATTenuation:AUTO OFF ON 0 1	278
[:SENSe]:ACP:OFFSet:LIST:RATTenuation:AUTO?	278
[:SENSe]:ACP:OFFSet:LIST:RATTenuation <rel_powr>,<rel_powr>,<rel_powr>,<rel_powr>,<rel_powr>	277
[:SENSe]:ACP:OFFSet:LIST:RATTenuation?	277
[:SENSe]:ACP:OFFSet:LIST:RCARrier <rel_power>,<rel_power>,<rel_power>,<rel_power>,<rel_power>	278
[:SENSe]:ACP:OFFSet:LIST:RCARrier?	278
[:SENSe]:ACP:OFFSet:LIST:RPSDensity <rel_power>,<rel_power>,<rel_power>,<rel_power>,<rel_power>	280
[:SENSe]:ACP:OFFSet:LIST:RPSDensity?	280
[:SENSe]:ACP:OFFSet:LIST:SIDE BOTH NEGative POSitive, BOTH NEGative POSitive, BOTH NEGative POSitive, BOTH NEGative POSitive, BOTH NEGative POSitive	281
[:SENSe]:ACP:OFFSet:LIST:SIDE?	281

List of Commands

[[:SENSe]:ACP:OFFSet:LIST:STATe OFF ON 0 1, OFF ON 0 1, OFF ON 0 1, OFF ON 0 1, OFF ON 0 1	282
[[:SENSe]:ACP:OFFSet:LIST:STATe?	282
[[:SENSe]:ACP:OFFSet:LIST:SWEep:TIME:AUTO OFF ON 0 1, OFF ON 0 1, OFF ON 0 1, OFF ON 0 1, OFF ON 0 1	283
[[:SENSe]:ACP:OFFSet:LIST:SWEep:TIME:AUTO?	283
[[:SENSe]:ACP:OFFSet:LIST:SWEep:TIME <seconds>,<seconds>,<seconds>,<seconds>,<seconds>	283
[[:SENSe]:ACP:OFFSet:LIST:SWEep:TIME?	283
[[:SENSe]:ACP:OFFSet:LIST:TEST ABSolute AND OR RELative, ABSolute AND OR RELative, ABSolute AND OR RELative, ABSolute AND OR RELative, ABSolute AND OR RELative	284
[[:SENSe]:ACP:OFFSet:LIST:TEST?	284
[[:SENSe]:ACP:OFFSet:LIST[:FREQuency] <f_offset>,<f_offset>,<f_offset>,<f_offset>,<f_offset>	274
[[:SENSe]:ACP:OFFSet:LIST[:FREQuency]?	274
[[:SENSe]:ACP:OFFSet:RCARrier <rel_power>	278
[[:SENSe]:ACP:OFFSet:RCARrier?	278
[[:SENSe]:ACP:OFFSet:RPSDensity <rel_power>	279
[[:SENSe]:ACP:OFFSet:RPSDensity?	280
[[:SENSe]:ACP:OFFSet:TEST ABSolute AND OR RELative	284
[[:SENSe]:ACP:OFFSet:TEST?	284
[[:SENSe]:ACP:OFFSet[n]:LIST:ABSolute <power>,<power>,<power>,<power>,<power>	270
[[:SENSe]:ACP:OFFSet[n]:LIST:ABSolute?	270
[[:SENSe]:ACP:OFFSet[n]:LIST:BANDwidth BWIDth <res_bw>,<res_bw>,<res_bw>,<res_bw>,<res_bw>	272
[[:SENSe]:ACP:OFFSet[n]:LIST:BANDwidth BWIDth?	272
[[:SENSe]:ACP:OFFSet[n]:LIST:RCARrier <rel_power>,<rel_power>,<rel_power>,<rel_power>,<rel_power>	278
[[:SENSe]:ACP:OFFSet[n]:LIST:RCARrier?	278
[[:SENSe]:ACP:OFFSet[n]:LIST:RPSDensity <rel_power>,<rel_power>,<rel_power>,<rel_power>,<rel_power>	280
[[:SENSe]:ACP:OFFSet[n]:LIST:RPSDensity?	280
[[:SENSe]:ACP:OFFSet[n]:LIST:STATe OFF ON 0 1, OFF ON 0 1,	

List of Commands

OFF ON 0 1, OFF ON 0 1, OFF ON 0 1.....	282
[:SENSe]:ACP:OFFSet[n]:LIST:STATe?	282
[:SENSe]:ACP:OFFSet[n]:LIST:TEST ABSolute AND OR RELative, ABSolute AND OR RELative, ABSolute AND OR RELative, ABSolute AND OR RELative, ABSolute AND OR RELative.....	284
[:SENSe]:ACP:OFFSet[n]:LIST:TEST?	284
[:SENSe]:ACP:OFFSet[n]:LIST[n]:BANDwidth BWIDTH <res_bw>,<res_bw>,<res_bw>,<res_bw>,<res_bw>	272
[:SENSe]:ACP:OFFSet[n]:LIST[n]:BANDwidth BWIDTH?.....	272
[:SENSe]:ACP:OFFSet[n]:LIST[n]:RCARrier <rel_power>,<rel_power>,<rel_power>,<rel_power>,<rel_power>.....	278
[:SENSe]:ACP:OFFSet[n]:LIST[n]:RCARrier?.....	278
[:SENSe]:ACP:OFFSet[n]:LIST[n]:RPSDensity <rel_power>,<rel_power>,<rel_power>,<rel_power>,<rel_power>.....	280
[:SENSe]:ACP:OFFSet[n]:LIST[n]:RPSDensity?.....	280
[:SENSe]:ACP:OFFSet[n]:LIST[n]:STATe OFF ON 0 1, OFF ON 0 1, OFF ON 0 1, OFF ON 0 1, OFF ON 0 1.....	282
[:SENSe]:ACP:OFFSet[n]:LIST[n]:STATe?.....	282
[:SENSe]:ACP:OFFSet[n]:LIST[n]:TEST, ABSolute AND OR RELative, ABSolute AND OR RELative, ABSolute AND OR RELative, ABSolute AND OR RELative.....	284
[:SENSe]:ACP:OFFSet[n]:LIST[n]:TEST?	284
[:SENSe]:ACP:OFFSet[n]:LIST[n][:FREQuency] <f_offset>,<f_offset>,<f_offset>,<f_offset>,<f_offset>.....	274
[:SENSe]:ACP:OFFSet[n]:LIST[n][:FREQuency]?.....	274
[:SENSe]:ACP:OFFSet[n]:LIST[:FREQuency] <f_offset>,<f_offset>,<f_offset>,<f_offset>,<f_offset>.....	274
[:SENSe]:ACP:OFFSet[n]:LIST[:FREQuency]?	274
[:SENSe]:ACP:OFFSet[:FREQuency] <f_offset>	274
[:SENSe]:ACP:OFFSet[:FREQuency]?	274
[:SENSe]:ACP:POINts <integer>	286
[:SENSe]:ACP:POINts:AUTO OFF ON 0 1	286
[:SENSe]:ACP:POINts:AUTO?	286
[:SENSe]:ACP:POINts?	286
[:SENSe]:ACP:SPECTrum:ENABle OFF ON 0 1	287

List of Commands

[:SENSe]:ACP:SPECtrum:ENABLE?	287
[:SENSe]:ACP:SWEep:BANDwidth BWIDth[:RESolution] <freq>	287
[:SENSe]:ACP:SWEep:BANDwidth BWIDth[:RESolution]:AUTO OFF ON 0 1	287
[:SENSe]:ACP:SWEep:BANDwidth BWIDth[:RESolution]:AUTO?	287
[:SENSe]:ACP:SWEep:BANDwidth BWIDth[:RESolution]?	287
[:SENSe]:ACP:SWEep:TIME <seconds>	288
[:SENSe]:ACP:SWEep:TIME:AUTO OFF ON 0 1	288
[:SENSe]:ACP:SWEep:TIME:AUTO?	288
[:SENSe]:ACP:SWEep:TIME?	288
[:SENSe]:ACP:TRIGger:SOURce EXTernal[1] EXTernal2 FRAMe IF IMMEDIATE RFBurst ..	289
[:SENSe]:ACP:TRIGger:SOURce?	289
[:SENSe]:ACP:TYPE PSDRef TPRef	290
[:SENSe]:ACP:TYPE?	290
[:SENSe]:CDPower:ASET:THReshold <rel_power>	293
[:SENSe]:CDPower:ASET:THReshold?	293
[:SENSe]:CDPower:AVERage:COUNt <integer>	292
[:SENSe]:CDPower:AVERage:COUNt?	292
[:SENSe]:CDPower:AVERage:TCONtrol EXPonential REPeat	292
[:SENSe]:CDPower:AVERage:TCONtrol?	292
[:SENSe]:CDPower:AVERage[:STATe] OFF ON 0 1	292
[:SENSe]:CDPower:AVERage[:STATe]?	292
[:SENSe]:CDPower:METHod FPOWER POWER TPHase	293
[:SENSe]:CDPower:METHod?	293
[:SENSe]:CDPower:SPECtrum INVert NORMal	293
[:SENSe]:CDPower:SPECtrum?	293
[:SENSe]:CDPower:SWEep:TIME <time>	294
[:SENSe]:CDPower:SWEep:TIME?	294
[:SENSe]:CHANnel:PNOFfset <integer>	294
[:SENSe]:CHANnel:PNOFfset?	294
[:SENSe]:CHPower:AVERage:COUNt <integer>	295
[:SENSe]:CHPower:AVERage:COUNt?	295

List of Commands

[[:SENSe]:CHPower:AVERage:TCONtrol EXPonential REPeat]	.296
[[:SENSe]:CHPower:AVERage:TCONtrol?	.296
[[:SENSe]:CHPower:AVERage[:STATe] OFF ON 0 1]	.295
[[:SENSe]:CHPower:AVERage[:STATe]?	.295
[[:SENSe]:CHPower:BANDwidth BWIDth:INTegration <freq>]	.296
[[:SENSe]:CHPower:BANDwidth BWIDth:INTegration?	.296
[[:SENSe]:CHPower:FREQuency:SPAN <freq>]	.297
[[:SENSe]:CHPower:FREQuency:SPAN?	.297
[[:SENSe]:CHPower:POINts <integer>]	.297
[[:SENSe]:CHPower:POINts:AUTO OFF ON 0 1]	.297
[[:SENSe]:CHPower:POINts:AUTO?	.297
[[:SENSe]:CHPower:POINts?	.297
[[:SENSe]:CHPower:SWEep:TIME <time>]	.298
[[:SENSe]:CHPower:SWEep:TIME:AUTO OFF ON 0 1]	.298
[[:SENSe]:CHPower:SWEep:TIME:AUTO?	.298
[[:SENSe]:CHPower:SWEep:TIME?	.298
[[:SENSe]:CHPower:TRIGger:SOURce EXTernal[1] EXTernal2 IMMediate]	.299
[[:SENSe]:CHPower:TRIGger:SOURce?	.299
[[:SENSe]:CORRection:BS[:RF]:LOSS <rel_power>]	.300
[[:SENSe]:CORRection:BS[:RF]:LOSS?	.300
[[:SENSe]:CORRection:MS[:RF]:LOSS <rel_power>]	.300
[[:SENSe]:CORRection:MS[:RF]:LOSS?	.300
[[:SENSe]:CSPur:AVERage:COUNt <integer>]	.301
[[:SENSe]:CSPur:AVERage:COUNt?	.301
[[:SENSe]:CSPur:AVERage:TCONtrol EXPonential REPeat]	.301
[[:SENSe]:CSPur:AVERage:TCONtrol?	.301
[[:SENSe]:CSPur:AVERage:TYPE LOG MAXimum RMS SCALar]	.302
[[:SENSe]:CSPur:AVERage:TYPE?	.302
[[:SENSe]:CSPur:AVERage[:STATe] OFF ON 0 1]	.301
[[:SENSe]:CSPur:AVERage[:STATe]?	.301
[[:SENSe]:CSPur:TYPE EXAMine FULL]	.302

List of Commands

[[:SENSe]:CSPur:TYPE?	302
[[:SENSe]:FEED RF AREFERENCE IFALIGN	304
[[:SENSe]:FEED RF IQ IONLY QONLY AREFERENCE IFALIGN	304
[[:SENSe]:FEED?	304
[[:SENSe]:POWER:IQ:RANGe[:UPPer] <power> [DBM] DBMV W	291
[[:SENSe]:POWER:IQ:RANGe[:UPPer]?	291
[[:SENSe]:POWER[:RF]:ATTenuation <rel_power>	305
[[:SENSe]:POWER[:RF]:ATTenuation?	305
[[:SENSe]:POWER[:RF]:RANGe:AUTO OFF ON 0 1	305
[[:SENSe]:POWER[:RF]:RANGe:AUTO?	305
[[:SENSe]:POWER[:RF]:RANGe[:UPPer] <power>	305
[[:SENSe]:POWER[:RF]:RANGe[:UPPer]?	305
[[:SENSe]:RADio:CARRier:NUMBer SINGLE MULTIPLE	307
[[:SENSe]:RADio:CARRier:NUMBer?	307
[[:SENSe]:RADio:DEVice BS MS	307
[[:SENSe]:RADio:DEVice?	307
[[:SENSe]:RADio:STANdard:BAND IS95A JSTD8 IS97D	307
[[:SENSe]:RADio:STANdard:BAND:CLASs BC0 BC1 BC3 BC4	308
[[:SENSe]:RADio:STANdard:BAND:CLASs?	308
[[:SENSe]:RADio:STANdard:BAND?	307
[[:SENSe]:RHO:AVERAge:COUNt <integer>	309
[[:SENSe]:RHO:AVERAge:COUNt?	309
[[:SENSe]:RHO:AVERAge:TCONtrol EXPonential REPeat	309
[[:SENSe]:RHO:AVERAge:TCONtrol?	309
[[:SENSe]:RHO:AVERAge[:STATe] OFF ON 0 1	309
[[:SENSe]:RHO:AVERAge[:STATe]?	309
[[:SENSe]:RHO:SPECTrum INVert NORMal	310
[[:SENSe]:RHO:SPECTrum?	310
[[:SENSe]:RHO:SWEep:TIME <time>	310
[[:SENSe]:RHO:SWEep:TIME?	310
[[:SENSe]:RHO:TRIGger:SOURce EXTernal[1] External2 FRAMe IF IMMEDIATE RFBurst ..	310

List of Commands

[[:SENSe]:RHO:TRIGger:SOURce?	310
[[:SENSe]:SPECTrum:ACQuisition:PACKing AUTO LONG MEDIUm SHORT	312
[[:SENSe]:SPECTrum:ACQuisition:PACKing?	312
[[:SENSe]:SPECTrum:ADC:DITHer[:STATe] AUTO ON OFF 2 1 0	312
[[:SENSe]:SPECTrum:ADC:DITHer[:STATe]?	312
[[:SENSe]:SPECTrum:ADC:RANGe AUTO APEak APLock M6 P0 P6 P12 P18 P24	312
[[:SENSe]:SPECTrum:ADC:RANGe AUTO APEak APLock NONE P0 P6 P12 P18	313
[[:SENSe]:SPECTrum:ADC:RANGe?	313
[[:SENSe]:SPECTrum:AVERage:CLear	314
[[:SENSe]:SPECTrum:AVERage:COUNT <integer>	314
[[:SENSe]:SPECTrum:AVERage:COUNT?	314
[[:SENSe]:SPECTrum:AVERage:TCONtrol EXPonential REPeat	315
[[:SENSe]:SPECTrum:AVERage:TCONtrol?	315
[[:SENSe]:SPECTrum:AVERage:TYPE LOG MAXimum MINimum RMS SCALar	315
[[:SENSe]:SPECTrum:AVERage:TYPE?	315
[[:SENSe]:SPECTrum:AVERage[:STATe] OFF ON 0 1	315
[[:SENSe]:SPECTrum:AVERage[:STATe]?	315
[[:SENSe]:SPECTrum:BANDwidth BWIDth:IF:AUTO OFF ON 0 1	316
[[:SENSe]:SPECTrum:BANDwidth BWIDth:IF:AUTO?	316
[[:SENSe]:SPECTrum:BANDwidth BWIDth:IF:FLATness OFF ON 0 1	316
[[:SENSe]:SPECTrum:BANDwidth BWIDth:IF:FLATness?	316
[[:SENSe]:SPECTrum:BANDwidth BWIDth:PADC OFF ON 0 1	317
[[:SENSe]:SPECTrum:BANDwidth BWIDth:PADC?	317
[[:SENSe]:SPECTrum:BANDwidth BWIDth:PFFT:TYPE FLAT GAUSSian	318
[[:SENSe]:SPECTrum:BANDwidth BWIDth:PFFT:TYPE?	318
[[:SENSe]:SPECTrum:BANDwidth BWIDth:PFFT[:SIZE] <freq>	317
[[:SENSe]:SPECTrum:BANDwidth BWIDth:PFFT[:SIZE]?	317
[[:SENSe]:SPECTrum:BANDwidth BWIDth[:RESolution] <freq>	318
[[:SENSe]:SPECTrum:BANDwidth BWIDth[:RESolution]:AUTO OFF ON 0 1	319
[[:SENSe]:SPECTrum:BANDwidth BWIDth[:RESolution]:AUTO?	319
[[:SENSe]:SPECTrum:BANDwidth BWIDth[:RESolution]?	318

List of Commands

[[:SENSe]:SPEcTrum:DECimate[:FACTor] <integer>	319
[[:SENSe]:SPEcTrum:DECimate[:FACTor]?	319
[[:SENSe]:SPEcTrum:FFT:LENGth <integer>	320
[[:SENSe]:SPEcTrum:FFT:LENGth:AUTO OFF ON 0 1	320
[[:SENSe]:SPEcTrum:FFT:LENGth:AUTO?	320
[[:SENSe]:SPEcTrum:FFT:LENGth?	320
[[:SENSe]:SPEcTrum:FFT:RBWPoints <real>	321
[[:SENSe]:SPEcTrum:FFT:RBWPoints?	321
[[:SENSe]:SPEcTrum:FFT:WINDow:DELay <real>	321
[[:SENSe]:SPEcTrum:FFT:WINDow:DELay?	321
[[:SENSe]:SPEcTrum:FFT:WINDow:LENGth <integer>	322
[[:SENSe]:SPEcTrum:FFT:WINDow:LENGth?	322
[[:SENSe]:SPEcTrum:FFT:WINDow[:TYPE] BH4Tap BLACKman FLATtop GAUSSian HAMMING HANNing KB70 KB90 KB110 UNIFORM	322
[[:SENSe]:SPEcTrum:FFT:WINDow[:TYPE]?	322
[[:SENSe]:SPEcTrum:FREQuency:SPAN <freq>	323
[[:SENSe]:SPEcTrum:FREQuency:SPAN?	323
[[:SENSe]:SPEcTrum:SWEep:TIME:AUTO OFF ON 0 1	324
[[:SENSe]:SPEcTrum:SWEep:TIME:AUTO	324
[[:SENSe]:SPEcTrum:SWEep:TIME?	323
[[:SENSe]:SPEcTrum:SWEep:TIME[:VALue] <time>	323
[[:SENSe]:SPEcTrum:TRIGger:SOURce EXTernal[1] EXTernal2 FRAME IF LINE IMMEDIATE RFBURSt	324
[[:SENSe]:SPEcTrum:TRIGger:SOURce?	324
[[:SENSe]:SYNC ESECond EXTernal[1] EXTernal2 NONE PSEQUence	325
[[:SENSe]:SYNC?	325
[[:SENSe]:VOLTage:IQ:RANGe[:UPPer] <level>	291
[[:SENSe]:VOLTage:IQ:RANGe[:UPPer]?	291
[[:SENSe]:WAVEform:ACQuistion:PACKing AUTO LONG MEDIUM SHORT	326
[[:SENSe]:WAVEform:ACQuistion:PACKing?	326
[[:SENSe]:WAVEform:ADC:DITHer[:STATe] OFF ON 0 1	326
[[:SENSe]:WAVEform:ADC:DITHer[:STATe]?	326

List of Commands

[[:SENSe]:WAVeform:ADC:FILTer[:STATe] OFF ON 0 1326
[[:SENSe]:WAVeform:ADC:FILTer[:STATe]?326
[[:SENSe]:WAVeform:ADC:RANGe AUTO APEak APLock GROund M6 P0 P6 P12 P18 P24327
[[:SENSe]:WAVeform:ADC:RANGe AUTO APEak APLock GROund NONE P0 P6 P12 P18327
[[:SENSe]:WAVeform:ADC:RANGe?327
[[:SENSe]:WAVeform:APERture?328
[[:SENSe]:WAVeform:AVERage:COUNT <integer>328
[[:SENSe]:WAVeform:AVERage:COUNT?328
[[:SENSe]:WAVeform:AVERage:TCONtrol EXPonential REPeat329
[[:SENSe]:WAVeform:AVERage:TCONtrol?329
[[:SENSe]:WAVeform:AVERage:TYPE LOG MAXimum MINimum RMS SCALar329
[[:SENSe]:WAVeform:AVERage:TYPE?329
[[:SENSe]:WAVeform:AVERage[:STATe] OFF ON 0 1328
[[:SENSe]:WAVeform:AVERage[:STATe]?328
[[:SENSe]:WAVeform:BANDwidth:RESolution]:ACTual?330
[[:SENSe]:WAVeform:BANDwidth BWIDth[:RESolution] <freq>330
[[:SENSe]:WAVeform:BANDwidth BWIDth[:RESolution]:TYPE FLATtop GAUSSian331
[[:SENSe]:WAVeform:BANDwidth BWIDth[:RESolution]:TYPE?331
[[:SENSe]:WAVeform:BANDwidth BWIDth[:RESolution]?330
[[:SENSe]:WAVeform:DECimate:STATe OFF ON 0 1332
[[:SENSe]:WAVeform:DECimate:STATe?332
[[:SENSe]:WAVeform:DECimate[:FACTor] <integer>331
[[:SENSe]:WAVeform:DECimate[:FACTor]?331
[[:SENSe]:WAVeform:SWEep:TIME <time>332
[[:SENSe]:WAVeform:SWEep:TIME?332
[[:SENSe]:WAVeform:TRIGger:SOURce EXTernal[1] EXTernal2 FRAME IF IMMEDIATE LINE RFBurst333
[[:SENSe]:WAVeform:TRIGger:SOURce?333

1 Introduction

This chapter provides overall information on the cdmaOne communications system Option BAC and describes cdmaOne measurements made by the analyzer. Installation instructions for adding this option to your analyzer are provided in this section, in case you purchased this option separately.

What Does the Agilent PSA Series or VSA E4406A Do?

This instrument can help determine if a cdmaOne transmitter is working correctly. When configured for cdmaOne, the instrument can be used for the testing of a cdmaOne transmitter, according to the Electronics Industry Association and Telecommunications Industry Association TIA/EIA-95B, TIA/EIA-97C, and TIA/EIA-98C documents. These documents define complex, multi-part measurements used to maintain an interference-free environment. For example, the documents include measuring the power of a carrier. This instrument automatically makes measurements using the measurement methods and limits defined in the standards. The detailed results displayed by the measurements allow you to analyze cdmaOne system performance. You may alter the measurement parameters for specialized analysis.

For infrastructure test, the instrument will test base station transmitters in a non-interfering manner by means of a coupler or power splitter.

This instrument makes the following measurements:

- Channel Power
- Modulation Accuracy (Rho)
- Spurious Close
- ACPR (Adjacent Channel Power Ratio)
- Code Domain - power, timing, and phase
- Spectrum (Frequency Domain)
- Waveform (Time Domain)

Installing Optional Measurement Personalities

When you install a measurement personality, you need to follow a three step process:

1. Determine whether your memory capacity is sufficient to contain all the options you want to load. If not, decide which options you want to install now, and consider upgrading your memory. Details follow in [“Do You Have Enough Memory to Load All Your Personality Options?”](#) on page 21.
2. Install the measurement personality firmware into the instrument memory. Details follow in [“Loading an Optional Measurement Personality”](#) on page 25.
3. Enter a license key that activates the measurement personality. Details follow in [“Obtaining and Installing a License Key”](#) on page 26.

Adding measurement personalities requires the purchase of an upgrade kit for the desired option. The upgrade kit contains the measurement personality firmware and an entitlement certificate that is used to generate a license key from the internet website. A separate license key is required for each option on a specific instrument serial number and host ID.

For the latest information on Agilent Spectrum Analyzer options and upgrade kits, visit the following web location:

http://www.agilent.com/find/sa_upgrades

Do You Have Enough Memory to Load All Your Personality Options?

If you do not have memory limitations then you can skip ahead to the next section [“Loading an Optional Measurement Personality”](#) on page 25. If after installing your options you get error messages relating to memory issues, you can return to this section to learn more about how to optimize your configuration.

If you have 64 MBytes of memory installed in your instrument, you should have enough memory to install at least four optional personalities, with plenty of memory for data and states.

The optional measurement personalities require different amounts of memory. So the number of personalities that you can load varies. This is also impacted by how much data you need to save. If you are having memory errors you must swap the applications in or out of memory as needed. If you only have 48 MBytes of memory, you can upgrade your

hardware to 64 MBytes.

Additional memory can be added to any PSA Series analyzer by installing Option 115. With this option installed, you can install all currently available measurement personalities in your analyzer and still have memory space to store more state and trace files than would otherwise be possible.

To see the size of your installed memory for PSA Series Spectrum Analyzers:

1. Ensure that the spectrum analyzer is in spectrum analyzer mode because this can affect the screen size.
2. Press **System, More, Show Hdw.**
3. Read Flash Memory size in the table. If Option 115 is installed (PSA only), the table will also show Compact Flash Type and Compact Flash Size.

PSA Flash Memory Size	Available Memory Without Option B7J and Option 122 or 140	Available Memory With Option B7J and Option 122 or 140
64 Mbytes	32.5 MBytes	30.0 MBytes
48 Mbytes	16.9 MBytes	14.3 MBytes

PSA Compact Flash Memory Size	Available Additional Memory for Measurement Personalities
512 Mbytes (Opt. 115)	512 MBytes

To see the size of your installed memory for E4406A Transmitter Testers:

1. Press the **System** key, **MORE (1 of 3)**, and **MORE (2 of 3)** keys.
2. Read the **File System Key** - The total of the entries for **Used** and **Free** memory will total the installed flash memory, either 48 or 64 MBytes.

If you have 48 MBytes of memory, and you want to install more than 3 optional personalities, you may need to manage your memory resources. The following section, [“How to Predict Your Memory Requirements” on page 23](#), will help you decide how to configure your installed options to provide optimal operation.

How to Predict Your Memory Requirements

If you plan to install many optional personalities, you should review your memory requirements, so you can determine whether you have enough memory (unless you have a PSA Series with Option 115). There is an Agilent “Memory Calculator” available online that can help you do this, or you can make a calculated approximation using the information that follows. You will need to know your instrument’s installed memory size as determined in the previous section and then select your desired applications.

NOTE If you have a PSA Series analyzer with Option 115, there is adequate memory to install all of the available optional personalities in your instrument.

To calculate the available memory on your E4406, see:
<http://sa.tm.agilent.com/E4406A/memory/>

To calculate the available memory on your PSA, see:
<http://sa.tm.agilent.com/PSA/memory/>

Select the “Memory Calculator” link. You can try any combination of available personalities to see if your desired configuration is compatible with your installed memory.

NOTE For PSA: After loading all your optional measurement personalities, you should have a reserve of ~2 MBytes memory to facilitate mode switching. Less available memory will increase mode switching time. For example, if you employ excessive free memory by saving files of states and/or data, your mode switching time can increase to more than a minute.

You can manually estimate your total memory requirements by adding up the memory allocations described in the following steps. Compare the desired total with the available memory that you identified in the previous section.

1. Program memory - Select option requirements from the table “[Measurement Personality Options and Memory Required](#)” on [page 24](#).
2. For PSA only: shared libraries require 7.72 MBytes.
3. For PSA only: recommended mode swap space is 2 MBytes.
4. Screens - .gif files need 20-25 kBytes each.
5. State memory - State file sizes range from 21 kB for SA mode to 40 kB for W-CDMA. The state of every mode accessed since power-on will be saved in the state file. File sizes can exceed 150 kB each when several modes are accessed, for each state file saved.

TIP State memory retains settings for all states accessed before the **Save State** command. To reduce this usage to a minimum, reduce the modes accessed before the **Save State** is executed. You can set the PSA to boot into a selected mode by accessing the desired mode, then pressing the **System, Power On/Preset, Power On** keys and toggle the setting to **Last**.

Measurement Personality Options and Memory Required

Personality Options for PSA Series Spectrum Analyzers ^a	Option	File Size (PSA Rev: A.10)
cdmaOne measurement personality	BAC	1.91 Mbytes
NADC and PDC measurement personalities (not available separately)	BAE	2.43 Mbytes
W-CDMA or W-CDMA, HSDPA, HSUPA measurement personality	BAF, 210	5.38 Mbytes ^b
cdma2000 or cdma2000 w/ 1xEV-DV measurement personality	B78, 214	4.00 Mbytes ^b
1xEV-DO measurement personality	204	5.61 Mbytes ^b
GSM (with EDGE) measurement personality	202	3.56 Mbytes ^b
Shared measurement library ^b	n/a	7.72 Mbytes
Phase Noise measurement personality	226	2.82 Mbytes ^c
Noise Figure measurement personality	219	4.68 Mbytes ^c
Basic measurement personality with digital demod hardware	B7J	Cannot be deleted (2.64 Mbytes)
Programming Code Compatibility Suite ^d (8560 Series, 8590 Series, and 8566/8568)	266	1.18 Mbytes ^c
TD-SCDMA Power measurement personality	211	5.47 Mbytes ^c
TD-SCDMA Modulation Analysis or TD-SCDMA Modulation Analysis w/ HSDPA/8PSK measurement personality	212, 213	1.82 Mbytes
Flexible Digital Modulation Analysis	241	2.11 Mbytes ^b
WLAN measurement personality	217	3.24 Mbytes ^b
External Source Control	215	0.72 Mbytes ^c
Measuring Receiver Personality (available with Option 23A - Trigger support for AM/FM/PM and Option 23B - CCITT filter)	233	2.91 Mbytes ^b
EMC Analyzer	239	4.06 Mbytes ^b

- a. Available as of the print date of this guide.
- b. Many PSA Series personality options use a 7.72 Mbyte shared measurement library. If you are loading multiple personalities that use this library, you only need to add this memory allocation once.
- c. Shared measurement library allocation not required.
- d. This is a no charge option that does not require a license key.

Personality Options for E4406A Transmitter Tester ^a	Option	File Size (E4406A Rev: A.10)
cdmaOne measurement personality	BAC	1.82 Mbytes
NADC measurement personality	BAE	1.10 Mbytes
PDC measurement personality	BAE	1.23 Mbytes
W-CDMA or W-CDMA, HSDPA, HSUPA measurement personality	BAF, 210	5.00 Mbytes
cdma2000 or cdma2000 w/ 1xEV-DV measurement personality	B78, 214	3.88 Mbytes
1xEV-DO measurement personality	204	4.84 Mbytes
GSM (with EDGE) measurement personality	202	3.56 Mbytes
GSM measurement personality	BAH	2.51 Mbytes
EDGE upgrade from BAH measurement personality	252 (202)	3.56 Mbytes
iDEN measurement personality	HN1	2.10 Mbytes
WiDEN measurement personality	HN1	1.58 Mbytes
Baseband I/Q Inputs	B7C	n/a (hardware only)

a. Available as of the print date of this guide.

Memory Upgrade Kits

The PSA 64 MByte Memory Upgrade kit part number is E4440AU-ANE. The PSA Compact Flash Upgrade kit part number is E4440AU-115.

The VSA 64 MByte Memory Upgrade kit part number is E4406AU-ANE.

For more information about memory upgrade kits contact your local sales office, service office, or see:

http://www.agilent.com/find/sa_upgrades

Loading an Optional Measurement Personality

You must use a PC to load the desired personality option into the instrument memory. Loading can be done from a firmware CD-ROM or by downloading the update program from the internet. An automatic loading program comes with the files and runs from your PC.

You can check the Agilent internet website for the latest PSA firmware versions available for downloading:

http://www.agilent.com/find/psa_firmware

You can check the Agilent internet website for the latest E4406 firmware versions available for downloading:

http://www.agilent.com/find/e4406a_firmware

NOTE

When you add a new option, or update an existing option, you will get the updated versions of all your current options as they are all reloaded simultaneously. This process may also require you to update the instrument core firmware so that it is compatible with the new option.

Depending on your installed hardware memory, you may not be able to fit all of the available measurement personalities in instrument memory at the same time. You may need to delete an existing option file from memory and load the one you want. Use the automatic update program that is provided with the files. Refer to the table showing “[Measurement Personality Options and Memory Required](#)” on page 24. The approximate memory requirements for the options are listed in this table. These numbers are worst case examples. Some options share components and libraries, therefore the total memory usage of multiple options may not be exactly equal to the combined total.

Obtaining and Installing a License Key

If you purchase an optional personality that requires installation, you will receive an “Entitlement Certificate” which may be redeemed for a license key specific to one instrument. Follow the instructions that accompany the certificate to obtain your license key.

To install a license key for the selected personality option, use the following procedure:

NOTE

You can also use this procedure to reinstall a license key that has been deleted during an uninstall process, or lost due to a memory failure.

For PSA:

1. Press **System, More, More, Licensing, Option** to access the alpha editor. Use this alpha editor to enter letters (upper-case), and the front-panel numeric keys to enter numbers for the option designation. You will validate your option entry in the active function area of the display. Then, press the **Enter** key.
2. Press **License Key** to enter the letters and digits of your license key. You will validate your license key entry in the active function area of the display. Then, press the **Enter** key.
3. Press the **Activate License** key.

For E4406:

1. Press **System, More, More, Install, Choose Option** to access the alpha editor. Use this alpha editor to enter letters (upper-case), and the front-panel numeric keys to enter numbers for the option designation. You will validate your option entry in the active function area of the display. Then, press the **Done** key.

NOTE

Before you enter the license key for the EDGE Retrofit Option 252, you must already have entered the license key for the GSM Option BAH.

2. Press **License Key** to enter the letters and digits of your license key. You will validate your license key entry in the active function area of the display. Then, press the **Done** key.
3. Press the **Install Now** key. The message “New option keys become active after reboot.” will appear, along with the **Yes/No** menu: press the **Yes** key and cycle the instrument power off and then on to complete your installation process, or press the **No** key to cancel the installation process.

Viewing a License Key

Measurement personalities purchased with your instrument have been installed and activated at the factory before shipment. The instrument requires a **License Key** unique to every measurement personality purchased. The license key is a hexadecimal number specific to your measurement personality, instrument serial number and host ID. It enables you to install, or reactivate that particular personality.

Use the following procedure to display the license key unique to your personality option that is already installed in your PSA:

Press **System, More, More, Licensing, Show License**. The **System, Personality** key displays the personalities loaded, version information, and whether the personality is licensed.

Use the following procedure to display the license key unique to your personality option that is already installed in your E4406:

Press **System, More, More, Install, Choose Option** to enter the letters and numbers for the option you want. You can see the key on the **License Key** menu key. Press the **Done** key.

NOTE

*You will want to keep a copy of your license key in a secure location. Press **System, More**, then **Licensing, Show License Show System**, and print out a copy of the display that shows the license numbers. If you should lose your license key, call your nearest Agilent Technologies service or sales office for assistance.*

Using the Delete License Key on PSA

This key will make the option unavailable for use, but will not delete it from memory. Write down the 12-digit license key for the option before you delete it. If you want to use that measurement personality later, you will need the license key to reactivate the personality firmware.

NOTE

Using the **Delete License** key does not remove the personality from the instrument memory, and does not free memory to be available to install another option. If you need to free memory to install another option, refer to the instructions for loading firmware updates located at the URL :
<http://www.agilent.com/find/psa/>

1. Press **System, More, More, Licensing, Option**. Pressing the **Option** key will activate the alpha editor menu. Use the alpha editor to enter the letters (upper-case) and the front-panel numeric keyboard to enter the digits (if required) for the option, then press the **Enter** key. As you enter the option, you will see your entry in the active function area of the display.
2. Press **Delete License** to remove the license key from memory.

Using the Uninstall Key on E4406A

This key will make the option unavailable for use, but will not delete it from memory. The message “Application Not Licensed” will appear in the Status/Info bar at the bottom of the display. Record the 12-digit license key for the option before you delete it. If you want to use that measurement personality later, you will need the license key to reactivate the personality firmware.

NOTE

Using the **Uninstall** key does not remove the personality firmware from the instrument memory, and does not free memory to be available to install another option. If you need to free memory to install another option, refer to the instructions for loading firmware updates available at the URL: <http://www.agilent.com/find/vsa/>

1. Press **System, More(1 of 3), More(2 of 3), Uninstall, Choose Option** to access the alpha editor. Use this alpha editor to enter the letters (upper-case), and the front-panel numeric keys to enter the numbers (if required) for the installed option. You will validate your option entry in the active function area of the display. Then, press the **Done** key.

2. Pressing the **Uninstall Now** key will activate the **Yes/No** menu: press the **Yes** key to continue your uninstall process, or press the **No** key to cancel the uninstall process.
3. Cycle the instrument power off and then on to complete the uninstall process.

Ordering Optional Measurement Personalities

When you order a personality option, you will receive an entitlement certificate. Then you will need to go to the Web site to redeem your entitlement certificate for a license key. You will need to provide your instrument serial number and host ID, and the entitlement certificate number.

Required Information:	Front Panel Key Path:
Model #: (Ex. E4440A)	
Host ID: _____	System, Show System
Instrument Serial Number: _____	System, Show System

2

Making Measurements

This chapter describes procedures used for making measurements of cdmaOne BTS or MS. Instructions to help you set up and perform the measurements are provided, and examples of cdmaOne measurement results are shown.

cdmaOne Measurements

Once in the cdmaOne mode, the following measurements are available by pressing the **MEASURE** key:

- “Channel Power Measurements” on page 44
- “Modulation Accuracy (Composite Rho) Measurements” on page 47
- “Code Domain Measurements (Base Station)” on page 51
- “Spur Close Measurements” on page 55
- “Spectrum (Frequency Domain) Measurements” on page 62
- “Waveform (Time Domain) Measurements” on page 77
- “Adjacent Channel Power Ratio (ACPR) Measurements” on page 38
- “Using Basic Mode” on page 89

These are referred to as one-button measurements. When you press the key to select the measurement it will become the active measurement, using settings and a display unique to that measurement. Data acquisitions will automatically begin provided trigger requirements, if any, are met.

Instrument Front Panel Highlights

The most commonly used function keys on the VSA and PSA front panels are located as shown in the illustrations below. The operation of the keys is briefly explained on the following page. Refer to your User's Guide for complete details on all keys.

Figure 2-1 Selected E4406A VSA Series Front Panel Feature Locations

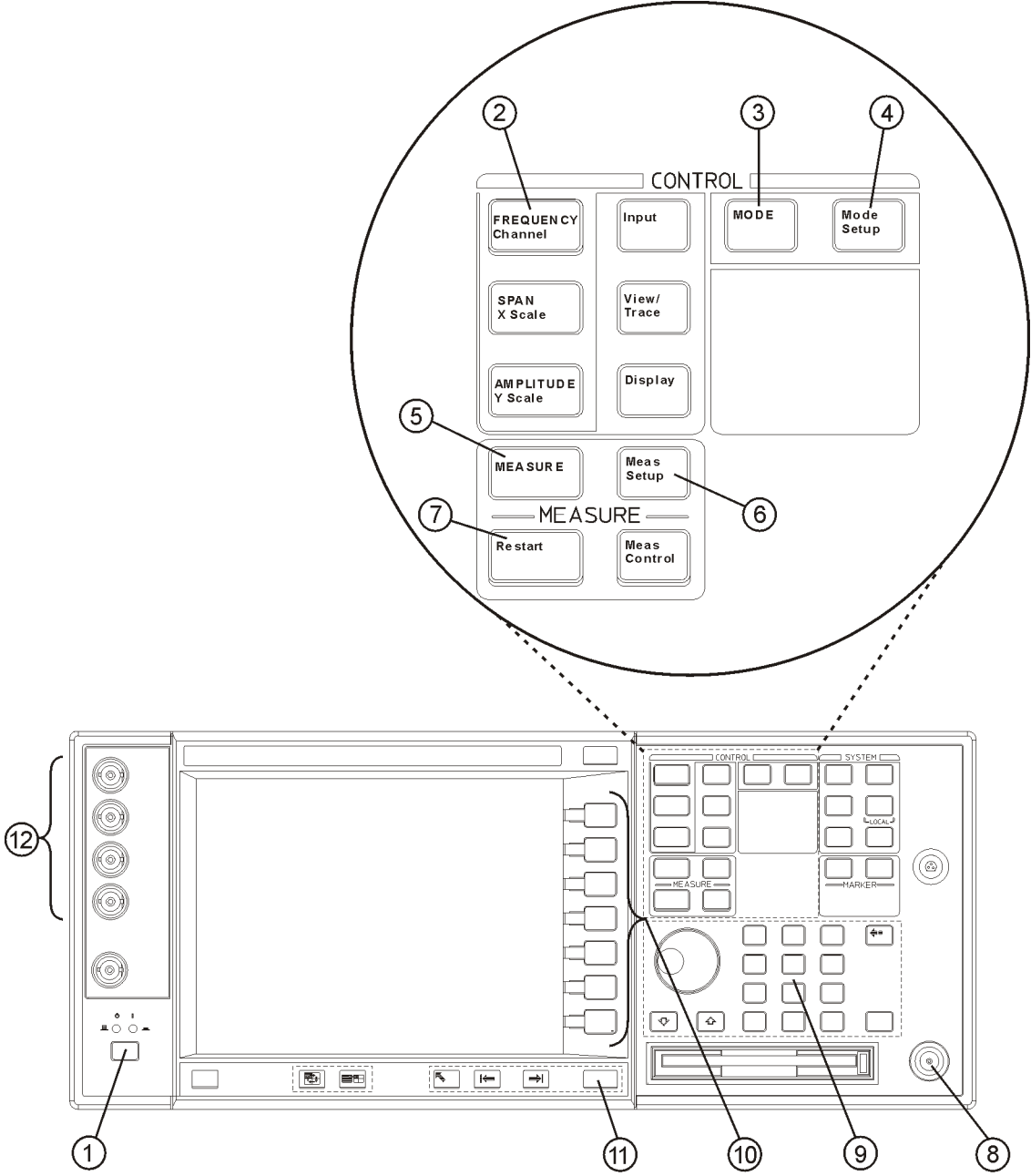

aa81a

Figure 2-2 Selected PSA Series Front Panel Feature Locations

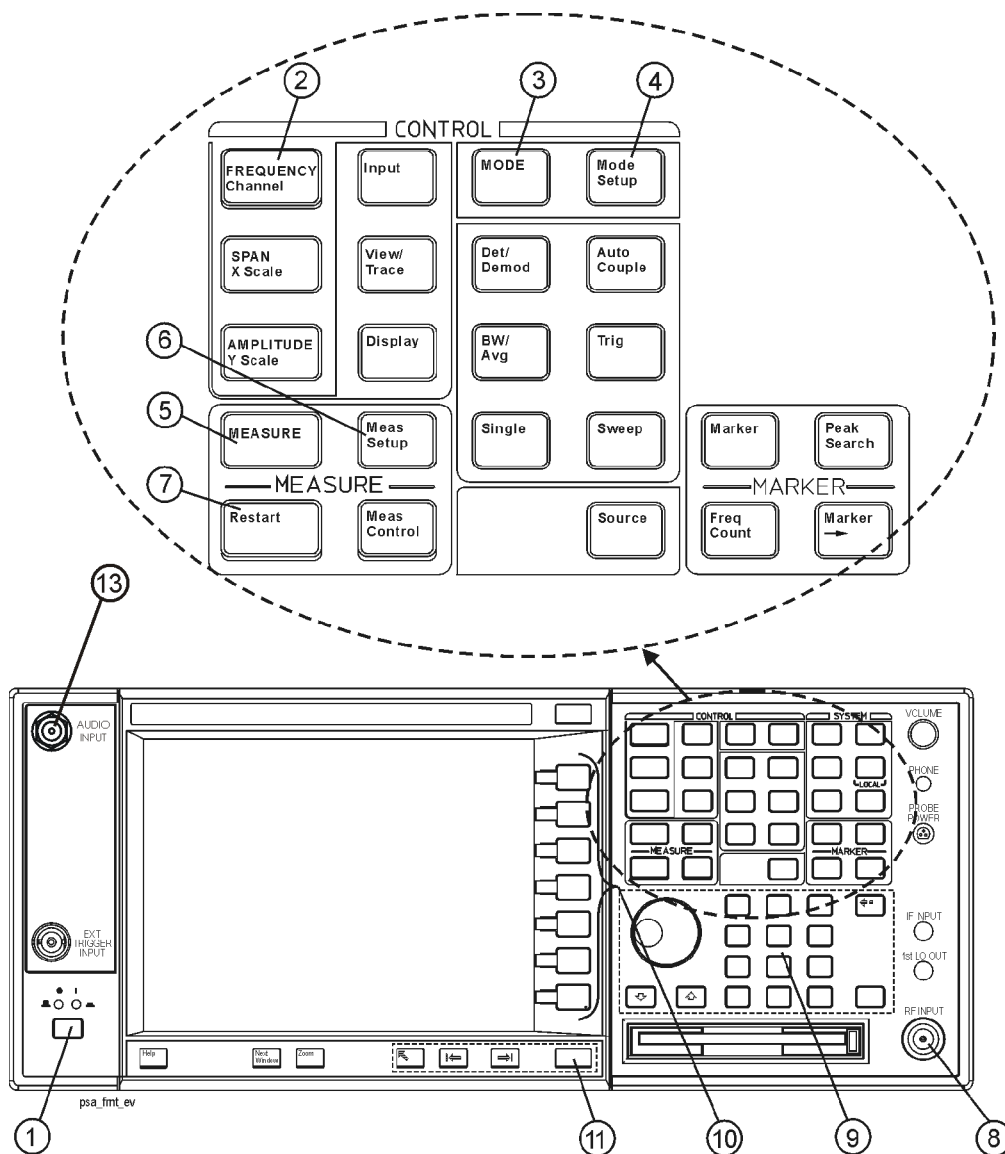

Selected E4406A VSA and PSA Front-Panel Features

1. The **On/Off** switch toggles the AC Line power between On and Standby. A green LED will light when the instrument is On. When energized in the standby mode, a yellow LED is lit above the switch.
2. **FREQUENCY Channel** accesses a key menu to set the analyzer center frequency in units of Hz, kHz, MHz, or GHz, or by channel number. These parameters apply to all measurements in the current mode.
3. **MODE** accesses a key menu to select one of the measurement

personalities installed in the instrument. Each mode is independent from all other modes.

4. **Mode Setup** accesses a key menu that sets parameters specific to the current mode and can affect all measurements within that mode.
5. **MEASURE** accesses a display key menu to initiate one of the various measurements that are specific to the current mode.
6. **Meas Setup** accesses the menus of test parameters that are specific to the current measurement.
7. **Restart** causes a measurement to start again from the initial process according to the current measurement setup parameters.
8. **RF INPUT** port: Type N connector for the E4406A VSA and E4443A, E4445A, and E4440A PSAs. It is a 2.4 mm connector on the E4446A and E4448A PSAs and a 3.5 mm connector on all PSAs with Opt BAB. The maximum input power level is shown next to the port.
9. The **Data Entry** keypad is used to enter numeric values. Keypad entries are displayed in the active function area of the screen and become valid for the current measurement upon pressing the **Enter** key or selecting a unit of measurement, depending on the parameter.
10. The Display Menu keys allow you either to activate a feature or to access a more detailed sub-menu. An arrow on the right side of a softkey label indicates that the key has a further selection menu. The active menu key is highlighted, however, grayed-out keys are currently unavailable for use or only show information. If a menu has multiple pages, successive pages are accessed by pressing the **More** key located at the bottom of the menu.
11. **Return** allows you to exit the current menu and display the previous menu. If you are on the first page of a mult-page menu (a menu with **(1 of 3)** for example), the **Return** key will exit from that menu. When you activate another measurement, the return list is cleared. The **Return** key will not return you to a previously activated mode, nor will it alter any values you have entered in previous menus.
12. **Baseband I/Q Inputs** (E4406A Option B7C only) Allow you to analyze signals at baseband frequencies.
13. **BNC Audio Input** (PSA Option 233 Measuring Receiver only) Provides a 100 kOhm input for audio measurements. Frequency range is 20 Hz to 250 kHz. The safe input level is 7 Vrms or 20 V DC.

Setting up and Making a Measurement

Making the Initial Signal Connection

CAUTION

Before connecting a signal to the instrument, make sure the instrument can safely accept the signal level provided. The signal level limits are marked next to the connectors on the front panel.

See “Input Key Menu” for details on selecting input ports and setting internal attenuation to prevent overloading the instrument.

For PSA only, the “Input Key Menu” also provides details of **Int Preamp** operation.

Using Instrument Mode and Measurement Presets

If you want to set your current measurement personality to a known, factory default state, press **Preset**. This initializes the instrument by returning the mode setup and all of the measurement setups in the mode to the factory default parameters.

NOTE

For PSA, note that pressing the **Preset** key will switch instrument modes unless the type of preset is selected under **System, Power On/Preset** is set to **Mode** or **Save User Preset**.

To preset only the parameters that are specific to an active, selected measurement, press **Meas Setup**, then **Restore Meas Defaults**. **Restore Meas Defaults** will return all the measurement setup parameters to the factory defaults, but only for the currently selected measurement. The **Restore Meas Defaults** key may not appear on the first page of the **Meas Setup** menu. If not, press **More** until the key is available.

The 3 Steps to Set Up and Make Measurements

All measurements need to be set up in 3 steps: first at the Mode level, second at the Measurement level, then finally the result display may be adjusted.

1. Select and Set Up the Mode

Press **MODE** - All licensed, installed Modes available are shown. Press **cdmaOne**, or select **Basic** mode to make measurements of signals with non-standard formats.

Press **Mode Setup** - Make any required adjustments to the mode settings. These settings apply to all measurement in the mode.

2. Select and Set Up the Measurement

Press **MEASURE** - Select a specific measurement to be performed (e.g. **ACP**, **Spectrum** or **Waveform**). The measurement begins as soon as any required trigger conditions are met. The resulting data is shown on the display or is available for export.

Press **Meas Setup** - Make any adjustments as required to the selected measurement settings. The settings only apply to this measurement.

3. Select and Set Up a View of the Results

Press **Trace/View** - Select a display format for the current measurement data. Depending on the mode and measurement selected, other graphical and tabular data presentations may be available. **X-Scale** and **Y-Scale** adjustments may also be made now.

NOTE

A setting may be reset at any time, and will be in effect on the next measurement cycle or View.

Step	Primary Key	Setup Keys	Related Keys
1. Select & set up a Mode	MODE	Mode Setup , Input (E4406A) , Input/Output (PSA) , FREQUENCY Channel	System
2. Select & set up a Measurement	MEASURE	Meas Setup	Meas Control , Restart
3. Select & set up a View of the Results	View/Trace (E4406A) , Trace/View (PSA)	SPAN X Scale , AMPLITUDE Y Scale , Display , Next Window , Zoom	File , Save , Print , Print Setup , Marker , Search (E4406A) , Peak Search (PSA)

Adjacent Channel Power Ratio (ACPR) Measurements

This section explains how to make an adjacent channel power ratio (ACPR) measurement on a cdmaOne cellular mobile station. ACPR is a measurement of the amount of interference, or power, in an adjacent frequency channel. The results are displayed as a bar graph or as spectrum data, along with measurement data at specified offset.

Configuring the Measurement System

The mobile station (MS) under test has to be set to transmit the RF power remotely through the system controller. This transmitting signal is connected to the instruments RF input port. Connect the equipment as shown.

Figure 2-3 Adjacent Channel Power Ratio Measurement System

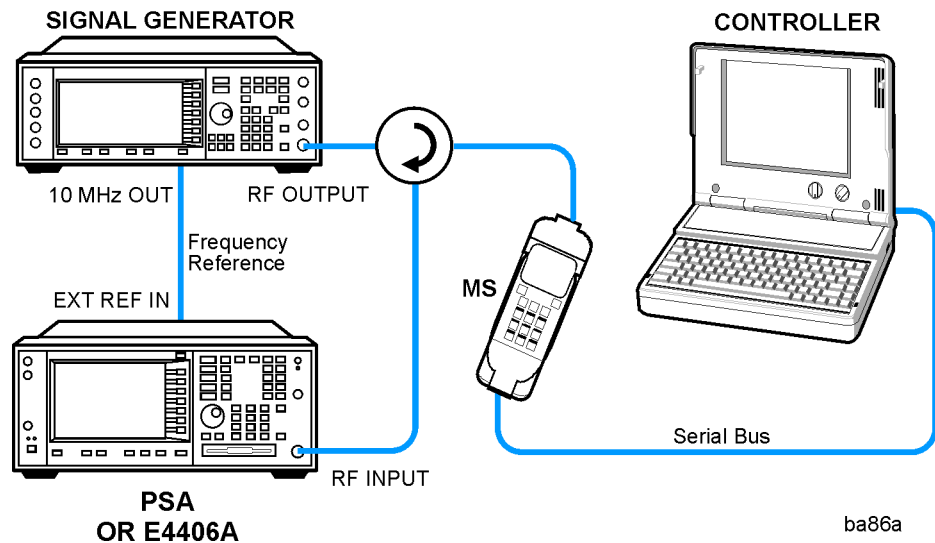

1. Using the appropriate cables, adapters, and circulator, connect the output signal from the MS to the RF input port of the instrument.
2. Connect the base transmission station simulator or signal generator to the MS through a circulator to initiate a link constructed with the sync and pilot channels, if required.
3. Connect a BNC cable between the 10 MHz OUT port of the signal generator and the EXT REF IN port of the instrument.
4. Connect the system controller to the MS through the serial bus cable to control the MS operation.

Setting the MS

From the base transmission station simulator and the system controller, set up a call using loopback mode to transmit the RF power.

Measurement Procedure

- Step 1.** Press the **Preset** key to preset the instrument. The settings will default to IS-95 standards.
- Step 2.** Press the **MODE**, **cdmaOneBasic** keys to enable the **cdmaOneBasic Mode** measurements.
- Step 3.** Press the **Mode Setup**, **Radio**, **Device** keys and toggle to select **MS** or **BTS**.
- Step 4.** To use settings different than for an IS-95 signal, press the **Meas Setup**, **Offsets and Limits** keys and select settings for your signal of interest. For more information see [“Adjacent Channel Power Ratio \(ACPR/ACLR\) Keys” on page 1](#).
- Step 5.** To set the measurement center frequency press the **FREQUENCY Channel** key, enter a numerical frequency using the front-panel keypad, and complete the entry by selecting a units key, like **MHz**. Depending on the measurement selected, you may have other keys available to select a channel or slot. For more information see **“FREQUENCY Channel Key Menu”**.
- Step 6.** Press the **MEASURE**, **ACP** keys to initiate the adjacent channel leakage power ratio measurement.

The following figure shows an example result of ACPR (Total Pwr Ref) measurements in the bar graph window. The absolute and relative power levels on both sides of the carrier frequency are displayed in the graphic window and text window.

Figure 2-4 ACPR Measurement - Bar Graph (Default) View

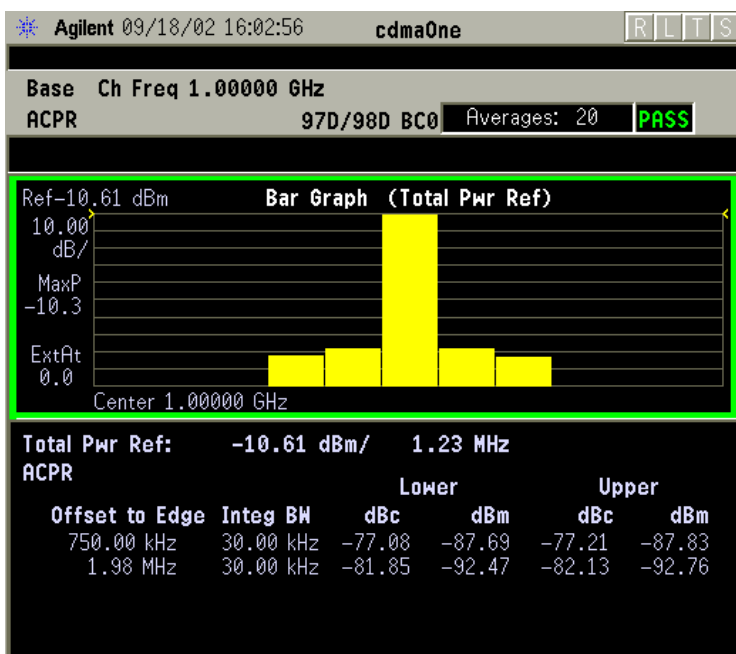
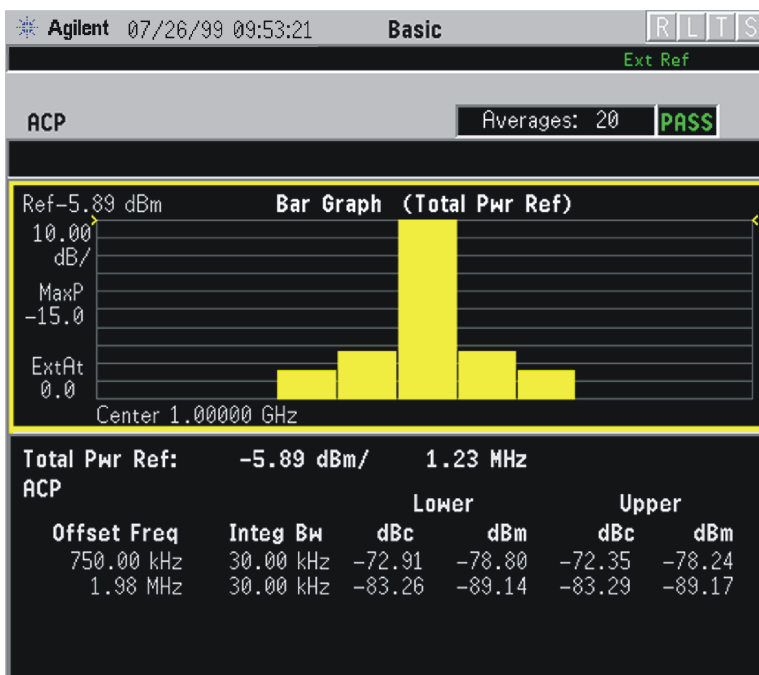

Figure 2-5 Basic ACP Measurement - Bar Graph (Default) View



The ACP Bar Graph measurement result should look like the above figure. The bar graph (referenced to the total power) and a text window are displayed. The text window shows the absolute total power reference, while the lower and upper offset channel power levels are displayed in both absolute and relative readings. In this example the test failed because of excessive power in the lower region.

In the factory default condition, 5 of the total integration power levels, centered at the carrier frequency and ± 765.0 kHz and ± 1.995 MHz offset frequencies, are shown in the default result display. The corresponding measured data is shown in the text window. When **Radio** is set to **IS-97D** **IS-98D**, Offset to Edge considering the measurement bandwidth is shown in the measurement result window instead of Offset Freq for other radios. Depending on the **Meas Type** selection, one of the two following displays is obtained:

Bar Graph (Total Pwr Ref) - A histogram of powers referenced to the total power

Bar Graph (PSD Ref) - A histogram of powers referenced to the mean power spectral density of the carrier in dBm/Hz

Step 7. Press the **View/Trace, Spectrum** keys to see the ACPR Spectrum graph view with the bandwidth marker lines in the graph window. In the factory default condition, the frequency spectrum with the FFT sweep type is displayed with the bandwidth marker lines in the graph window. The corresponding measured data in the text window is the total integration power levels, in dBc and dBm, within the defined bandwidth as shown in the figure below.

Figure 2-6 ACPR Measurement - Spectrum View

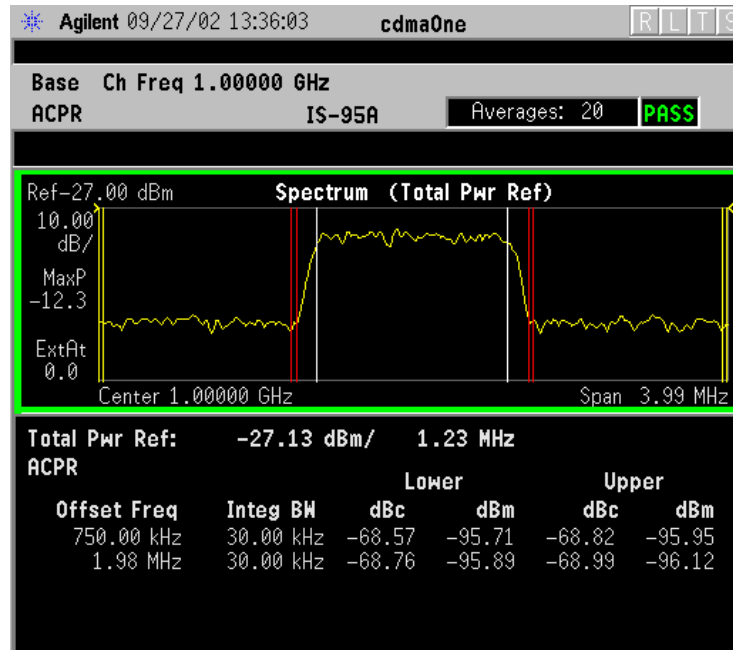
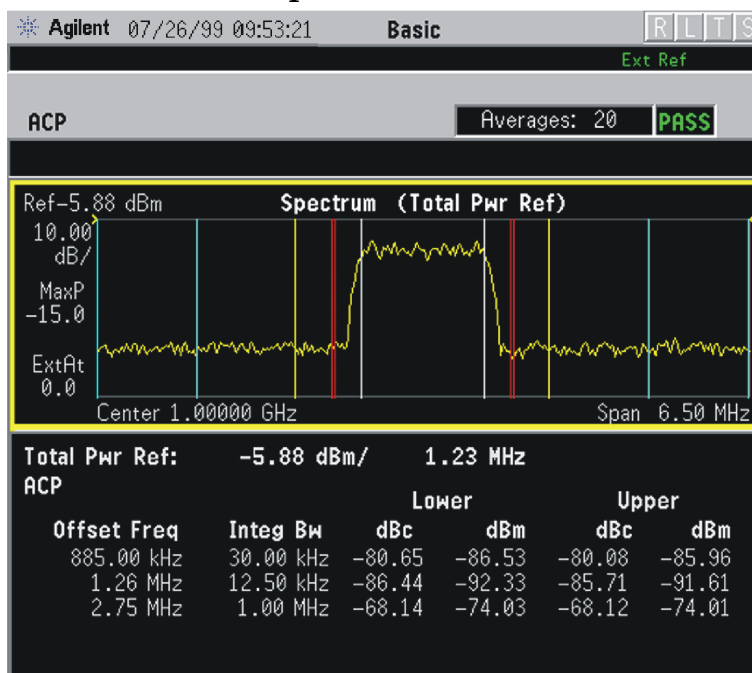

Figure 2-7 ACP Measurement - Spectrum View



Step 8. If desired, select a **Meas Type** setting. Depending on the **Meas Type** setting, one of the two following displays is obtained:

Spectrum (Total Pwr Ref) - A spectrum display referenced to the total power

Spectrum (PSD Ref) - A spectrum display referenced to the mean power spectral density of the carrier in dBm/Hz

You can improve the update speed of the displayed data values by turning off the spectrum trace in **Meas Setup**.

If **Sweep Type** is set to **Swp**, the swept frequency ACPR is displayed as shown below and only **Spectrum** is available for **View/Trace**.

While in this view, you can change the vertical scale by pressing the **AMPLITUDE Y Scale** key.

NOTE The **Marker** key is not available for this measurement.

Troubleshooting Hints

The adjacent channel power ratio measurement can reveal degraded or defective parts in the transmitter section of the UUT. The following examples are some areas which can contribute to poor ACPR:

- DC power supply control of the transmitter power amplifier, RF power control of the pre-power amplifier stage, and/or I/Q control of the baseband stage.

- Gain and output power levels of the power amplifier, caused by degraded gain control and/or increased distortion.
- Amplifier linearity.

Power amplifiers are one of the final stage elements of a base or mobile transmitter and are a critical part of meeting the important power and spectral efficiency specifications. Since ACPR measures the spectral response of the amplifier to a complex wideband signal, it is a key measurement linking amplifier linearity and other performance characteristics to the stringent system specifications.

NOTE

If an external attenuator is used, be sure to use the **Ext RF Atten** key to include the attenuation value in the displayed measurement result.

For more information on ACP measurements see [“Adjacent Channel Power Ratio \(ACPR/ACLR\) Measurement Concepts”](#) on page 1.

Channel Power Measurements

This section explains how to make a cdmaOne cellular measurement on a cdmaOne cellular mobile station. This test measures the total RF power present in the channel. The results are displayed graphically as well as in total power (dB) and power spectral density (dBm/Hz).

Configuring the Measurement System

The mobile station (MS) under test has to be set to transmit the RF power remotely through the system controller. This transmitting signal is connected to the instrument's RF input port. Connect the equipment as shown.

Figure 2-8

Channel Power Measurement System

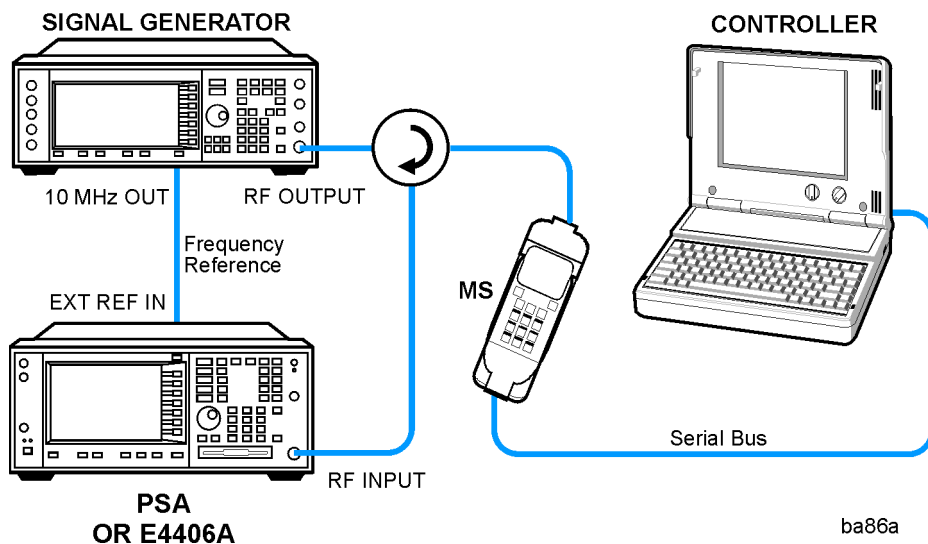

1. Using the appropriate cables, adapters, and circulator, connect the output signal from the MS to the RF input port of the instrument.
2. Connect the base transmission station simulator or signal generator to the MS through a circulator to initiate a link constructed with the sync and pilot channels, if required.
3. Connect a BNC cable between the 10 MHz OUT port of the signal generator and the EXT REF IN port of the instrument.
4. Connect the system controller to the MS through the serial bus cable to control the MS operation.

Setting Up the MS

From the base transmission station simulator and the system controller, set up a call using loopback mode for the MS to transmit RF power.

Measurement Procedure

- Step 1.** Press the **Preset** key to preset the instrument.
- Step 2.** Press the **System, Reference, Freq Ref** keys to toggle the frequency reference to EXT, if required. In the annunciator bar you will see EXT REF displayed in green.
- Step 3.** Press the **MODE, More (1 of 2), cdmaOnebasic** keys to enable cdmaOneBasic Mode measurements.
- Step 4.** Press the **Mode Setup, Radio, Device** keys and toggle to select **MS** or **BTS**.
- Step 5.** Press the **MEASURE, Channel Power** keys to initiate the channel power measurement.
- Step 6.** Press the **FREQUENCY Channel** key to set the measurement center frequency. This frequency should be at the exact center of the band for which you want to measure the channel power.
- Step 7.** Press the **Meas Setup, Chan Power Span** keys to set the display span for the channel power measurement. (This does not set the integration bandwidth. See **Integ BW** in Step 8 below.) Enter a number by using the front panel keypad, and selecting a unit of frequency like **1855, MHz**, or by rotating the RPG knob. This setting should be the exact desired span of the channel for which you have set the center frequency in Step 5 above. See [“Channel Power Keys” on page 1](#) for more information.
- Step 8.** Set the power measurement integration bandwidth for the channel power measurement. Press the **Integ BW** key, and enter a number by using the front panel keypad, and selecting a unit of frequency like **1855, MHz**, or by rotating the RPG knob. The adjustment of this value is coupled to the measurement span setting. The setting can be any integer frequency between 10% and 61.5% of the span of the channel which you set in Step 6 above. If desired, once the bandwidth setting is accomplished, the channel power span may be reset to a value greater than that allowed by the Span coupling function. The fastest measurement speed is obtained by using a channel power span that is only slightly greater than the integration bandwidths. Using Channel Power Spans that are much greater than the integration bandwidths slow the measurement and may degrade accuracy.

For more information see [“Channel Power Measurement Concepts” on page 1](#)

Figure 2-9 Channel Power Measurement Result

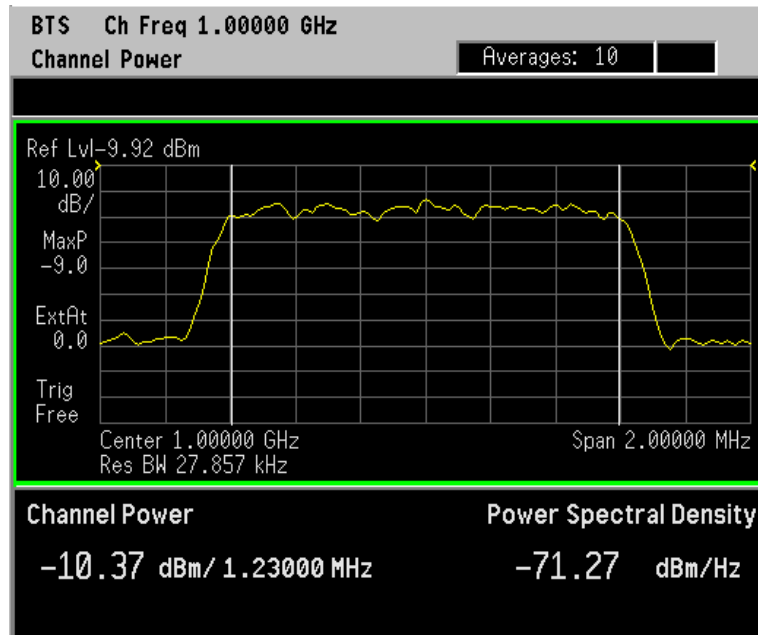

Your result should look like the screen above. The total RF power in the measurement channel span is shown at the left of the lower text window. The vertical white lines indicate the integration bandwidth setting.

Step 9. Press the **Meas Setup, More (1 of 2)** keys to check the keys available to change the measurement parameters from the default condition.

Troubleshooting Hints

If an external attenuator is used, be sure to use the **Ext RF Atten** key to include the attenuation value in the displayed measurement result.

The channel power measurement can reveal the effects of degraded or defective parts in the transmitter section of the UUT. The following are areas of concern which can contribute to performance degradation:

- DC power supply control of the transmitter power amplifier, RF power control of the pre-power amplifier stage, and/or I/Q control of the baseband stage.
- Gain and output power levels of the power amplifier, caused by degraded gain control and/or increased distortion.
- Amplifier linearity.

Modulation Accuracy (Composite Rho) Measurements

This section explains how to make a modulation accuracy (composite Rho) measurement on a cdmaOne mobile station. Rho is the ratio of the correlated power in a multi coded channel to the total signal power.

Configuring the Measurement System

The mobile station (MS) under test has to be set to transmit the RF power remotely through the system controller. This transmitting signal is connected to the instruments RF input port. Connect the equipment as shown.

Figure 2-10 Modulation Accuracy Measurement System

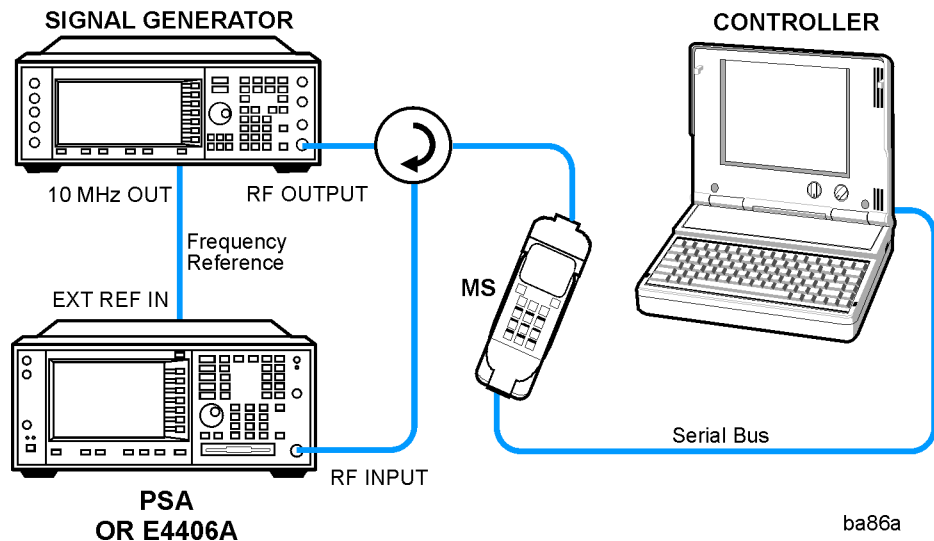

1. Using the appropriate cables, adapters, and circulator, connect the output signal of the MS to the RF input of the instrument.
2. Connect the base transmission station simulator or signal generator to the MS through a circulator to initiate a link constructed with sync and pilot channels, if required.
3. Connect a BNC cable between the 10 MHz OUT port of the signal generator and the EXT REF IN port of the instrument.
4. Connect the system controller to the MS through the serial bus cable to control the MS operation.

Setting the MS

From the base transmission station simulator and the system controller, set up a test mode that modulates only the known short code sequences in the reverse link. The measurement will not work with a live phone call on which data is being modulated.

Measurement Procedure

- Step 1.** Press the **Preset** key to preset the instrument.
- Step 2.** Press the **MODE, More (1 of 2), cdmaOne** keys to enable the cdmaOne measurements.
- Step 3.** Press the **Mode Setup, Radio, Device** to toggle the device to **MS**.
- Step 4.** Press the **FREQUENCY Channel, Center Frequency** keys, and enter the center frequency by using the numeric front-panel keypad, then select a units key like **MHz**, to set the center frequency. You can also set the frequency by selecting the **Channel Number** key, and then inputting a channel number using the numeric front-panel keypad, then press **Enter**.
- Step 5.** Press the **MEASURE, Mod Accuracy (RHO)** keys to initiate the measurement.

Figure 2-11 Modulation Accuracy Result - I/Q Measured Compl Vector View

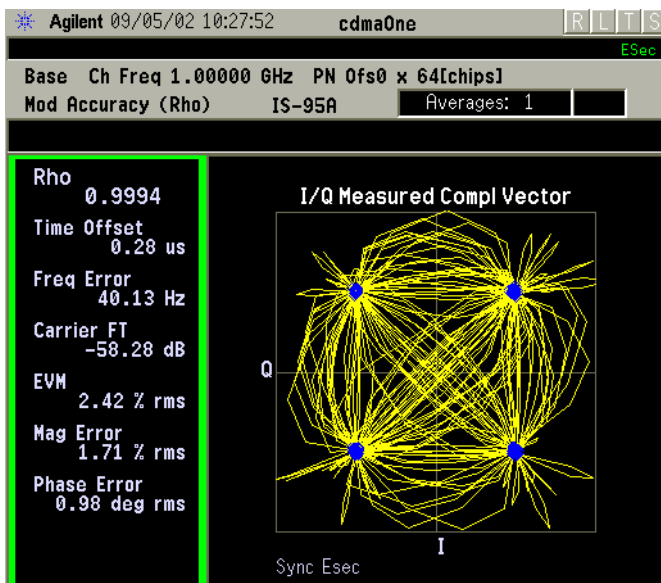

The Mod Accuracy: I/Q Measured Polar Vector measurement result should look like the above figure. The measurement values for modulation accuracy are shown in the summary result window.

Step 6. Press the **View/Trace**, and **I/Q Measured Compl Vector** keys to access a menu which allows you to change the display format to a polar mode, and allows you to choose to turn off the constellation dots in the display.

- **Compl Vector** - Sets view to the I/Q complementary vector graph of the I/Q signals before the IS-95 complementary filter.
- **Compl Constln** - Sets view to the I/Q complementary constellation graph of the I/Q signals before the IS-95 complementary filter.
- **Polar Vector** - Sets view to the I/Q polar vector graph of the I/Q signals after the IS-95 complementary filter.
- **Polar Constln** - Sets view to the I/Q polar constellation graph of the I/Q signals after the IS-95 complementary filter.

Step 7. Press the **View/Trace**, **I/Q Error (Quad View)** keys to display a combination view of the Mag Error, Phase Error, and EVM graphs versus chips in the graph window and the numeric measurement results for Rho, Time Offset, Freq Error in the text window.

Figure 2-12 Modulation Accuracy Result - I/Q Error View (chip dots on)

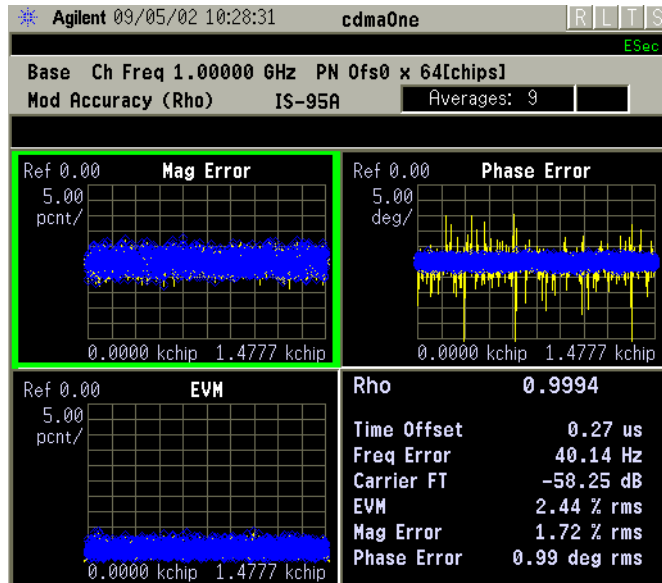

Any of these windows can be selected using the **Next Window** key and made full size using the **Zoom** key.

Step 8. Press the **Display** key access a menu to set the display control as follows:

- **I/Q Points** - Allows you to specify the number of displayed points for the I/Q waveforms. The range is 1 to 5000 points. The default setting is 750.
- **Points/Chip** - Allows you to set the number of sample points displayed per chip to either 2, 4, or 8. The default selection is 4.
- **Chip Dots** - Allows you to switch the chip dot display between **On** and **Off**. The default setting is **On**. Set to **Off** if you do not want the chip dots to be superimposed on the result traces.

Step 9. Press the **Marker** front-panel key to access the menu to configure the markers depending on the display selected:

- **Select** - Allows you to activate up to four markers with the corresponding numbers, respectively. The selected number is underlined and its function is defined by pressing the **Function** key. The default setting is 1.
- **Normal** - Allows you to activate the selected marker to read the magnitude or phase error and the number of chips of the marker position on the selected trace, for example. Marker position is controlled by the RPG knob.
- **Delta** - Allows you to read the differences in the magnitude or phase errors and the number of chips between the selected marker and the next.
- **Function** - Allows you to set the selected marker function to **Band Power**, **Noise**, or **Off**. The default setting is **Off**. The **Band Power** and **Noise** functions are not available for this measurement.
- **Trace** - Allows you to place the selected marker on the **EVM**, **Phase Error**, or **Mag Error** trace. The default setting is **EVM**.
- **Off** - Allows you to turn off the selected marker.
- **Shape** - Allows you to access the menu to set the selected marker shape to **Diamond**, **Line**, **Square**, or **Cross**. The default setting is **Diamond**.
- **Marker All Off** - Allows you to turn off all of the markers.

Step 10. Press the **Meas Setup, More (1 of 2)** keys to check the keys available to change the measurement parameters from the default condition.

If you have a problem, and get an error message, see [“If You Have a Problem” on page 90](#).

Code Domain Measurements (Base Station)

This section explains how to make a code domain measurement on a cdmaOne mobile station. This is the measurement of the power levels of the spread channels in composite RF channels, relative to the total power within the 1.23 MHz channel bandwidth centered at the center frequency.

Configuring the Measurement System

The base transmission station (BS) under test has to be set to transmit the RF power remotely through the system controller. The cdmaOne modulated interference signal is injected to the antenna output port of the BS through an attenuator and circulator. The transmitting signal from the BS is connected to the RF input port of the instrument from the circulator port. Connect the equipment as shown.

Figure 2-13 Intermodulation Product Measurement System

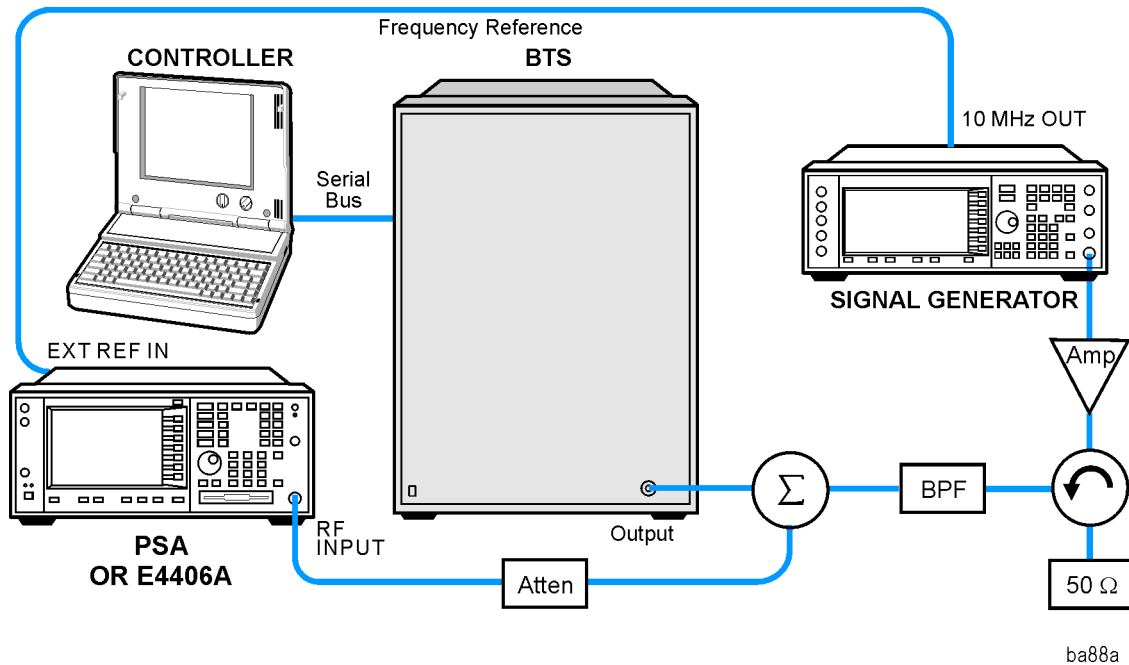

1. Using the appropriate amplifier, circulator, bandpass filter, combiner, cables, and adapters, connect the unmodulated carrier signal from the signal generator to the output connector of the BTS.
2. Connect the circulator output signal to the RF input port of the instrument through the attenuator.
3. Connect a BNC cable between the 10 MHz OUT port of the signal generator and the EXT REF IN port of the instrument.

4. Connect the system controller to the BTS through the serial bus cable.

Setting the MS

From the base transmission station simulator and the system controller, set up a call using loopback mode to transmit RF power.

Measurement Procedure

- Step 1.** Press the **Preset** key to preset the instrument.
- Step 2.** Press the **MODE, More (1 of 2), cdma2000** keys to enable the cdma2000 measurements.
- Step 3.** Press the **Mode Setup, Radio, Device** to toggle the device to **MS**.
- Step 4.** Press the **FREQUENCY Channel, Center Frequency** keys, and enter the center frequency by using the numeric front-panel keypad, then select a units key like **MHz**, to set the center frequency. You can also set the frequency by selecting the **Channel Number** key, and then inputting a channel number using the numeric front-panel keypad, then press **Enter**.
- Step 5.** Press the **MEASURE, Code Domain** keys to initiate the code domain measurement.

The next figure shows an example result of a Code Domain Power measurement. In the graph window, the active channel Walsh code and symbol rates are shown with those widths of the bars and the measured channel powers are shown with those heights. The time offset, frequency error, carrier feedthrough, pilot channel power, paging channel power, and so forth are shown in the text window.

Figure 2-14 Code Domain Measurement - Power Graph and Metrics View

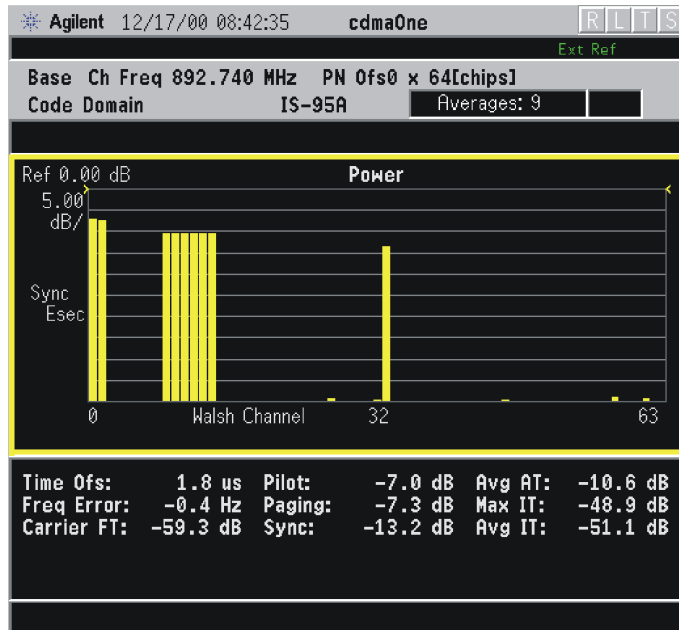

The Code Domain: Power measurement result should look like the above figure. The graph window and a text window is displayed. The text window shows the total power level along with the relative power levels of the various channels.

- Step 6.** Press the **View/Trace** and **Power Graph & Markers** keys to display a combination view of the code domain power graph with markers and the numeric results measured at up to four marker points .

Figure 2-15 Code Domain Measurement - Power Graph and Markers View

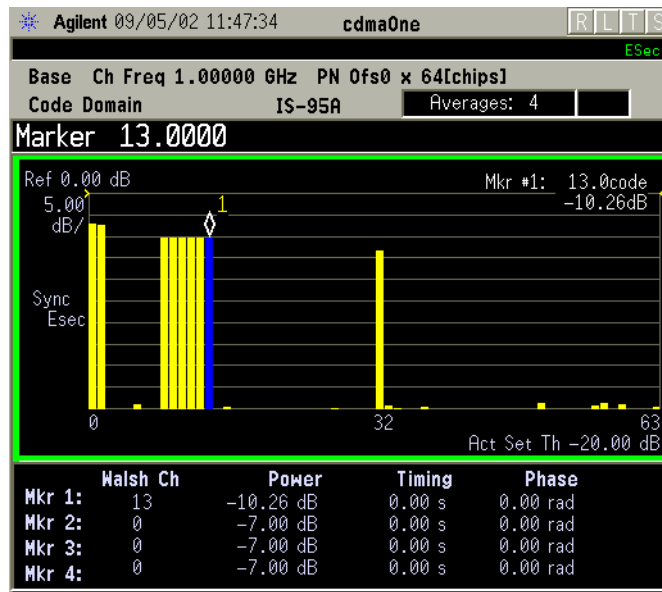

- Step 7.** Press the **Meas Setup** key, and press the **Measurement Method** key to select **Timing Phase**. This will allow the last selection under the **View/Trace** key, **Power Timing and Phase** to be selected.

Figure 2-16 Code Domain Measurement - Power, Timing, and Phase View

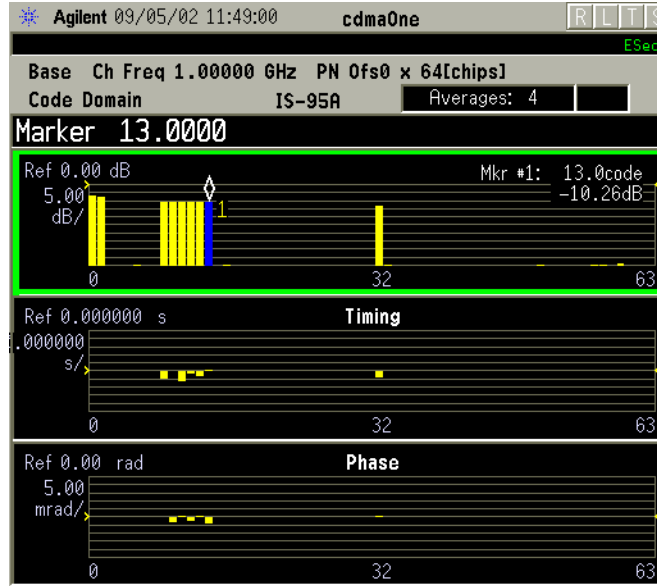

- Step 8.** To make a measurement repeatedly, press **Meas Control**, **Measure** to toggle the setting from **Single** to **Cont**.
- Step 9.** Press the **Meas Setup**, **More (1 of 3)**, **More (2 of 3)** keys to check the keys available to change the measurement parameters from the default condition.

If you have a problem, and get an error message, see [“If You Have a Problem” on page 90](#) or the “Instrument Messages and Functional Tests” manual.

Spur Close Measurements

This procedure measures the spurious emissions in the transmit band relative to channel power in the selected channel. The unit under test is typically set for maximum output power. The measurement can be used when the unit under test is set for output power less than maximum, however the limits used might not be correct.

Configuring the Measurement System

The mobile station (MS) under test has to be set to transmit the RF power remotely through the system controller. This transmitting signal is connected to the instruments RF input port. Connect the equipment as shown.

Figure 2-17 Modulation Accuracy Measurement System

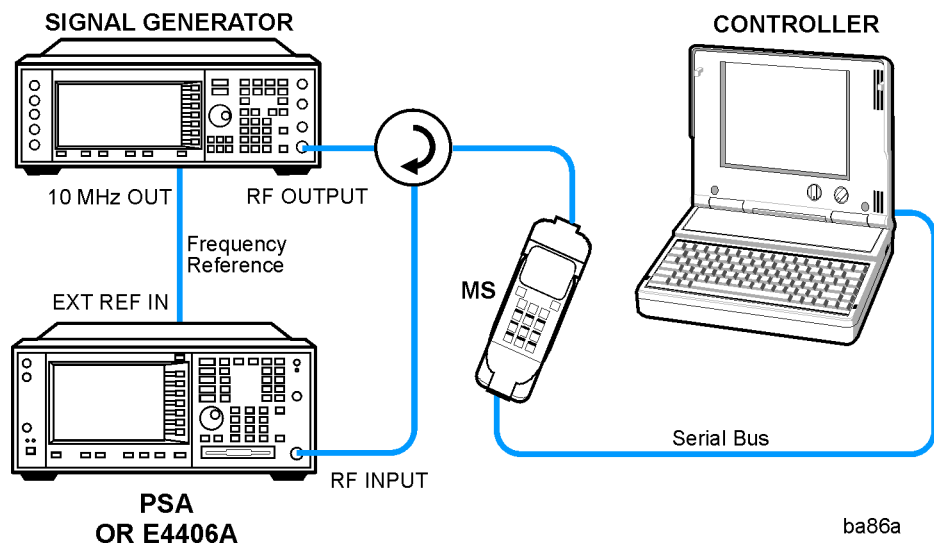

1. Using the appropriate cables, adapters, and circulator, connect the output signal of the MS to the RF input of the instrument.
2. Connect the base transmission station simulator or signal generator to the MS through a circulator to initiate a link constructed with sync and pilot channels, if required.
3. Connect a BNC cable between the 10 MHz OUT port of the signal generator and the EXT REF IN port of the instrument.
4. Connect the system controller to the MS through the serial bus cable to control the MS operation.

Setting the MS

From the base transmission station simulator and the system controller, set up a test mode that modulates only the known short code sequences in the reverse link. The measurement will not work with a live phone call on which data is being modulated.

Measurement Procedure

- Step 1.** Press the **Preset** key to preset the instrument.
- Step 2.** Press the **MODE, More (1 of 2), cdmaOne** keys to enable the cdmaOne measurements.
- Step 3.** Press the **Mode Setup, Radio, Device** to toggle the device to **MS**.
- Step 4.** Press **Radio Standard**, and select the appropriate radio standard for your device. If you select **IS-97D IS98D**, you also need to select a **Band Class** setting.
- Step 5.** Press the **FREQUENCY Channel, Center Frequency** keys, and enter the center frequency by using the numeric front-panel keypad, then select a units key like **MHz**, to set the center frequency. You can also set the frequency by selecting the **Channel Number** key, and then inputting a channel number using the numeric front-panel keypad, then press **Enter**.
- Step 6.** Press the **MEASURE, Spur Close** keys to initiate the measurement.

The following figure shows an example result of Spur Close Spectrum measurement. In the graph window, the center segment spectrum is shown with the limit mask. The total channel power, the worst spur levels from the carrier level and limit level are displayed in the text window. The measurement is repeated continuously.

Figure 2-18 IS-95A Spur Close Measurement - Center Segment View

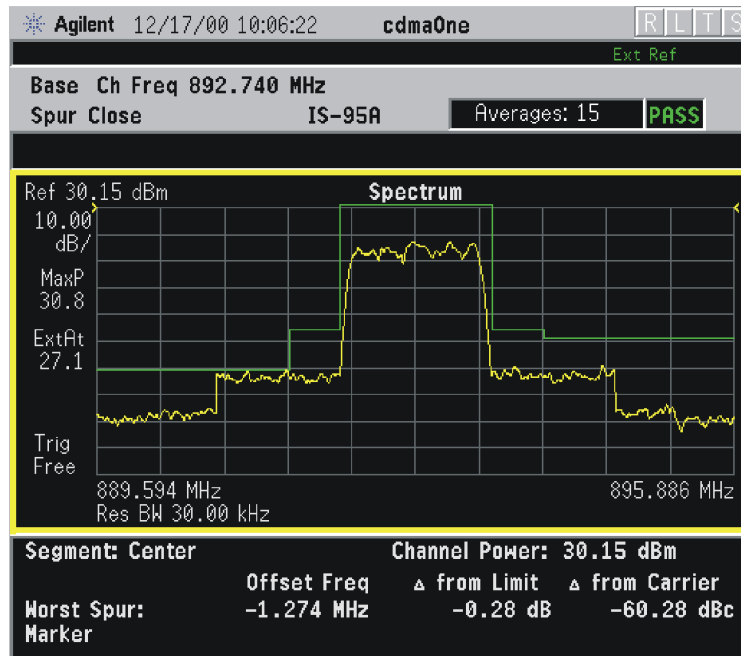

Step 7. Press the **Meas Control**, **Measure** keys to toggle the measurement to **Single** from **Cont**. This will restart a single measurement, and allow you to select a single segment of the spectrum being measured for further investigation.

Step 8. Press the **View/Trace** key. When **Radio Std** is set to **IS-95A**, or when **Radio Std** is set to **IS-97D IS-98D** and **Band Class** is set to **0 (800 MHz)** or **3 (JTACS)** for **Base** and **Mobile** tests, or when **Band Class** is set to **1 (1900 MHz)** or **4 (Korean PCS)** for **Mobile** tests, you can select from three measurement segments as follows:

- **Lower Segment**
- **Center Segment**
- **Upper Segment**

When **Radio Std** is set to **J-STD-008**, or when **Radio Std** is set to **IS-97D IS-98D** and **Band Class** is set to **1 (1900 MHz)** or **4 (Korean PCS)** for **Base** tests, you can select from five measurement segments as follows:

- **Lower Segment**
- **Lower Adj Segment** - Lower 1 MHz adjacent segment
- **Center Segment**
- **Upper Adj Segment** - Upper 1 MHz adjacent segment
- **Upper Segment**

Figure 2-19 IS-95A Spur Close Measurement - Lower Segment View

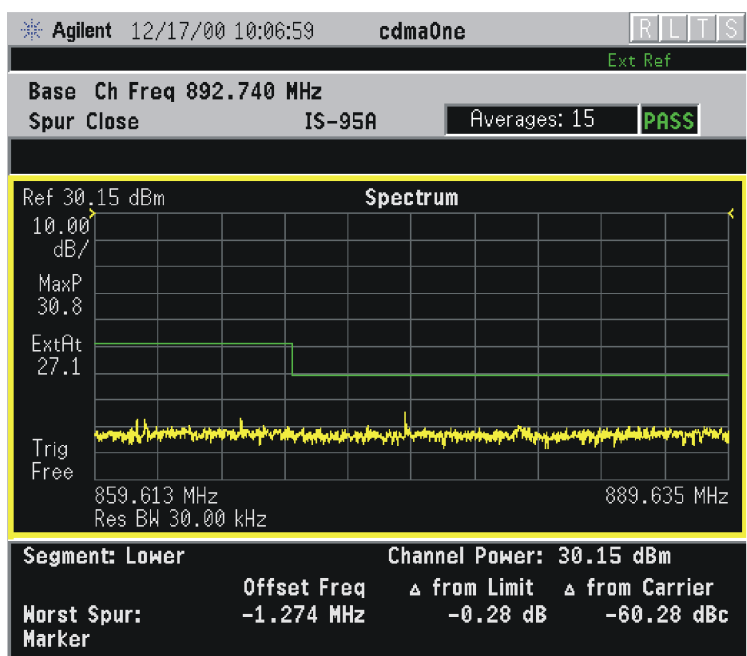
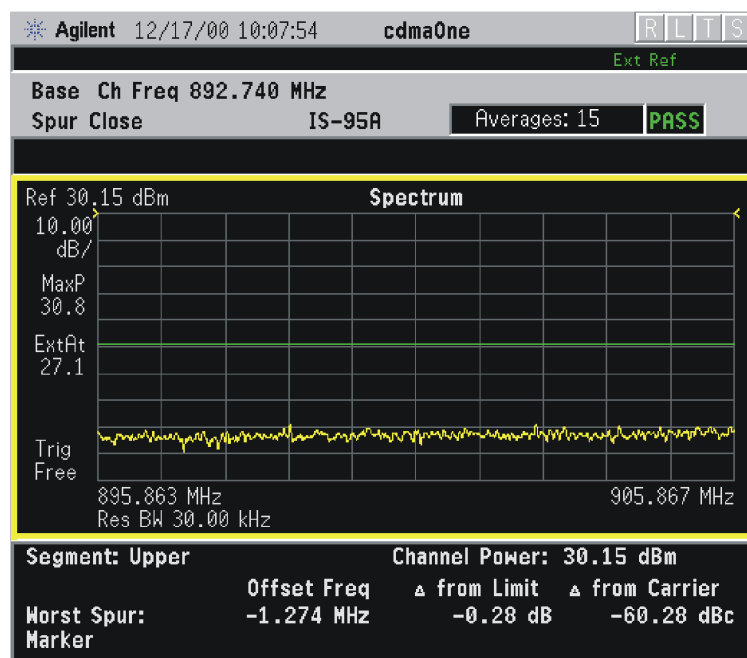

Figure 2-20 IS-95A Spur Close Measurement - Upper Segment View



- Step 9.** Press the **Peak Search** front-panel key to set a marker on the highest spur in the display.
- Step 10.** Press the **Marker** front-panel key to access the menu to configure the markers depending on the display selected.

Step 11. Press the **Meas Setup, More (1 of 2)** keys to check the keys available to change the measurement parameters from the default condition.

Changing the Measurement Setup

This table shows the factory default settings for spurious close measurements.

Table 2-1 Spur Close Measurement Defaults

Measurement Parameter	Factory Default Condition
View/Trace	Center Segment
Avg Number	15; On
Avg Mode	Repeat
Meas Type	Full
Tx Spur >4 MHz Limit	Category A

Make sure the **Spur Close** measurement is selected under the **MEASURE** menu. Press the **Meas Setup** key to access a menu which allows you to modify the averaging parameters as described in [“Setting up and Making a Measurement”](#) on page 36.

In addition, the following parameters can be modified according to your measurement requirement:

- **Meas Type** - Allows you to toggle the measurement bandwidth between **Full** and **Examine**. If set to **Full**, all segments are measured and displayed. If set to **Examine** with the continuous measurement mode, each segment is repetitively measured and the segment where the worst spurious signal is found can be repetitively measured and displayed for further tests.
- **Tx Spur >4 MHz Limit** - Allows you to access the selection menu for the limit masks at the frequency offset more than 4 MHz.
 - **Category A** - Sets to use the limit level of power spectral density – 13 dBm/100 kHz for Band Class 0 or 3, or – 13 dBm/1 MHz for Band Class 1 or 4.
 - **Category B** - Sets to use the limit level of power spectral density – 36 dBm/100 kHz for Band Class 0 or 3, or – 30 dBm/1 MHz for Band Class 1 or 4.
 - **None** - Sets not to use the limit mask, and **Upper Segment** and **Lower Segment** are grayed out.

Changing the View

The **View/Trace** key will allow you to select the desired view of the measurement from the following. Each of these choices selects a different part of the frequency spectrum for viewing. The Center Segment shows the spectrum centered on the carrier channel frequency.

Changing the Display

The **AMPLITUDE Y Scale** key accesses the menu to set the desired measurement scale and associated parameters:

- **Scale/Div** - Allows you to enter a numeric value to change the vertical display sensitivity. The range is 0.10 to 20.00 dB with 0.01 dB resolution. The default setting is 10.00 dB. However, since the **Scale Coupling** default is **On**, this value is automatically determined by the measurement result. When you set a value manually, **Scale Coupling** automatically changes to **Off**.
- **Ref Value** - Allows you to set the absolute power reference value ranging from -250.00 to 250.00 dBm with 0.01 dB resolution. The default setting is 10.00 dBm. However, since the **Scale Coupling** default is **On**, this value is automatically determined by the measurement result. When you set a value manually, **Scale Coupling** automatically changes to **Off**.
- **Ref Position** - Allows you to set the reference position to either **Top**, **Ctr** (center), or **Bot** (bottom). The default setting is **Top**.
- **Scale Coupling** - Allows you to toggle the scale coupling function between **On** and **Off**. The default setting is **On**. Upon pressing the **Restart** front-panel key or the **Restart** softkey under the **Meas Control** menu, this function automatically determines the scale per division and reference values based on the measurement results. When you set a value to either **Scale/Div** or **Ref Value** manually, **Scale Coupling** automatically changes to **Off**.

Using the Markers

The **Marker** front-panel key accesses the menu to configure the markers.

- **Select 1 2 3 4** - Allows you to activate up to four markers with the corresponding numbers, respectively. The selected number is underlined and its function is defined by pressing the **Function** key. The default is 1.
- **Normal** - Allows you to activate the selected marker to read the time position and amplitude of the marker on the Signal envelope trace, for example. Marker position is controlled by the **RPG** knob.
- **Delta** - Allows you to read the differences in time positions and amplitudes between the selected marker and the next.

- **Function** - Allows you to define the selected marker function to be **Band Power**, **Noise**, or **Off**. The default is **Off**. For measuring **Band Power**, you need to place the **Normal** marker and then place the **Delta** marker.
- **Trace** - Allows you to place the selected marker on the **Spectrum** trace.
- **Off** - Allows you to turn off the selected marker.
- **Shape Diamond** - Allows you to access the menu to define the selected marker shape to be **Diamond**, **Line**, **Square**, or **Cross**. The default is **Diamond**.
- **Marker All Off** - Allows you to turn off all of the markers.

The front-panel **Search** key performs a peak search when pressed. A marker will automatically be activated at the highest peak.

Spectrum (Frequency Domain) Measurements

This section explains how to make a frequency domain measurement on a cdmaOne base station. An adjacent or an interfering signal can also be applied, if desired, during spectrum measurements.

If installed, you may use PSA Option 122, the 80 MHz Bandwidth Digitizer hardware, or PSA Option 140, the 40 MHz Bandwidth Digitizer hardware to perform Waveform measurements of wideband signals using Basic Mode.

Configuring the Measurement System

This example shows a base station (BTS) under test set up to transmit RF power, and being controlled remotely by a system controller. The transmitting signal is connected to the analyzer RF input port. Connect the equipment as shown.

Figure 2-21 Spectrum Measurement System

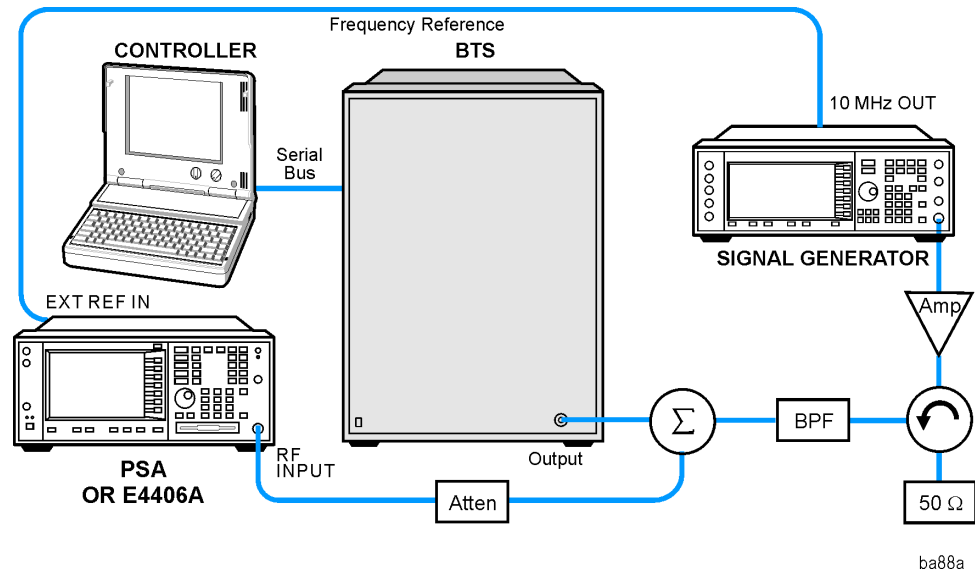

1. Using the appropriate cables, adapters, and circulator, connect the output signal of the BTS to the RF input of the instrument.
2. Connect the base transmission station simulator or signal generator to the BTS through a circulator to initiate a link constructed with sync and pilot channels, if required.
3. Connect a BNC cable between the 10 MHz OUT port of the signal generator and the EXT REF IN port of the instrument.
4. Connect the system controller to the BTS through the serial bus cable to control the BTS operation.

Setting the BTS

From the base transmission station simulator and the system controller, set up a call using loopback mode to allow the BTS to transmit an RF signal.

Measurement Procedure

- Step 1.** Press the **Preset** key to preset the instrument.
- Step 2.** Press the **MODE**, **cdma One Basic** keys to enable the **cdmaOne Basic Mode** measurements.
- Step 3.** To set the measurement center frequency press the **FREQUENCY Channel** key, enter a numerical frequency using the front-panel keypad, and complete the entry by selecting a units key, like **MHz**.
- Step 4.** Press the **SPAN** key, enter a numerical span using the front-panel keypad, and press the **MHz** key to set the measurement span in MHz.
- Step 5.** Press the **MEASURE** to initiate the spectrum measurement, which is the default measurement for **cdmaOne Basic**.

NOTE

A display with both a **Spectrum** window and an **I/Q Waveform** window will appear when you activate a **Spectrum** measurement. The active window is outlined in green. Changes to **FREQUENCY**, **Span**, or **Amplitude** settings will affect only the active window. Use the **Next Window** key to select a different window, and the **Zoom** key to enlarge a window.

The default display shows both **Current** (yellow trace) and **Average** (blue trace) data. To make viewing the display easier, you can view either the **Current** trace or **Average** separately.

- Press **Trace/View**, **Trace Display**, and select the trace(s) desired for display.

Figure 2-22 Spectrum Measurement - Spectrum and I/Q Waveform (Default View)

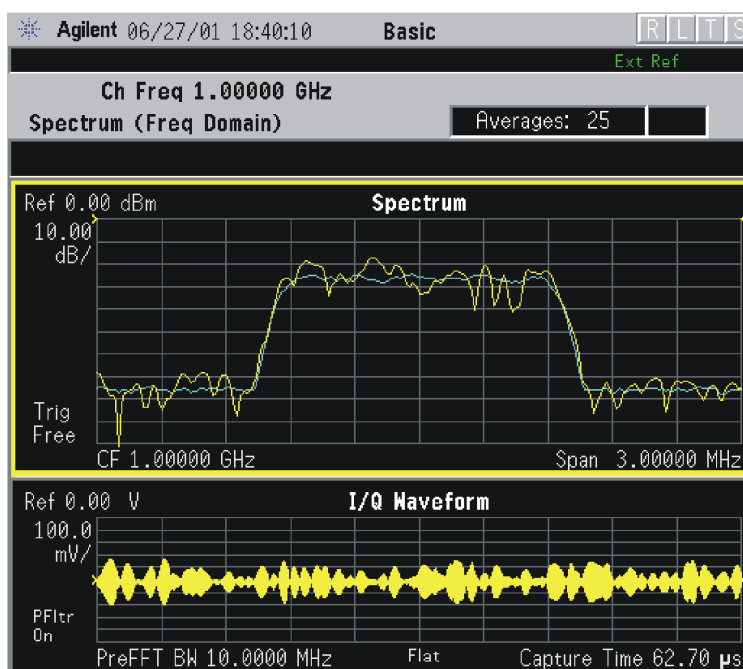
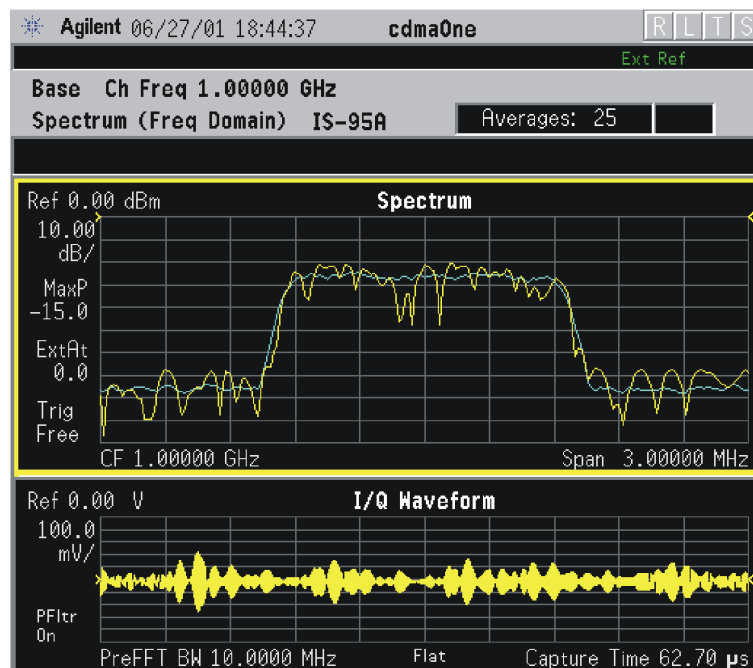

Figure 2-23 Spectrum Measurement - Spectrum and I/Q Waveform (Default View)



The spectrum measurement result should look like the above figure. The measurement result values are shown in the summary result window.

Step 6. Press the **View/Trace** key to display a menu allowing selection of another measurement result display including the following:

- **Spectrum** - Provides a combination view of the spectrum graph in parameters of power versus frequency with semi-log graticules, and the I/Q waveform graph in parameters of voltage and time. Changes to frequency span or power will sometimes affect data acquisition. This is equivalent to changing the selected window with the **Next** key.

Spectrum (Time Domain) I/Q Waveform - (Key for PSA only) This graph is shown below the Spectrum graph in the default dual-window display. I/Q Waveform provides a view of the I/Q waveform in parameters of voltage versus time in linear scale. Changes to sweep time or resolution bandwidth can affect data acquisition.

Figure 2-24 Spectrum (Time Domain) Measurement - I/Q Waveform Result

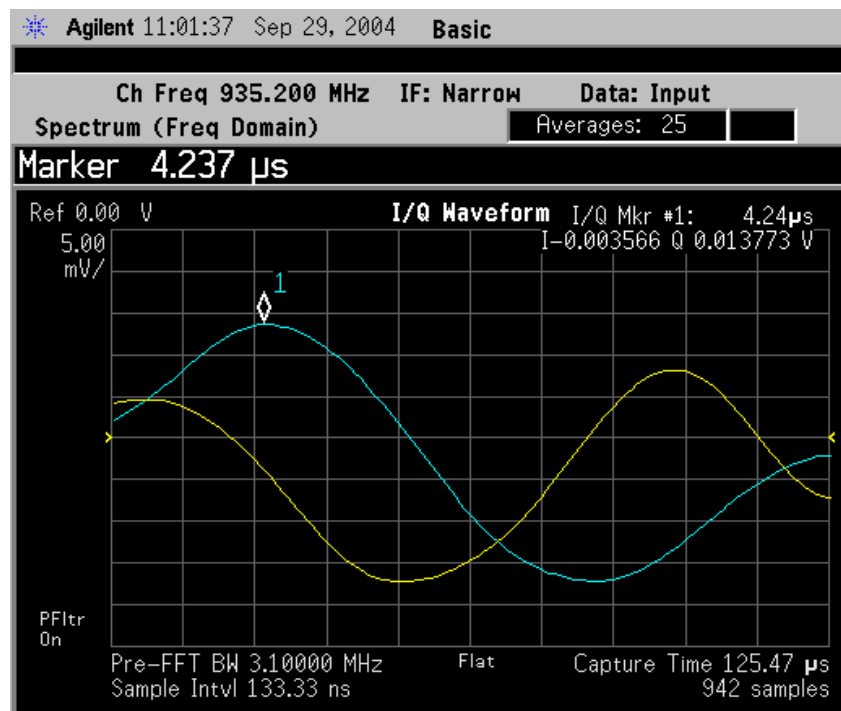

- **Spectrum Linear** - (E4406A) Provides a view of the spectrum graph in parameters of voltage versus frequency in linear scale. Changes to the frequency span or voltage can affect data acquisition.

Figure 2-25 Spectrum Measurement - Linear Spectrum View (for E4406A)

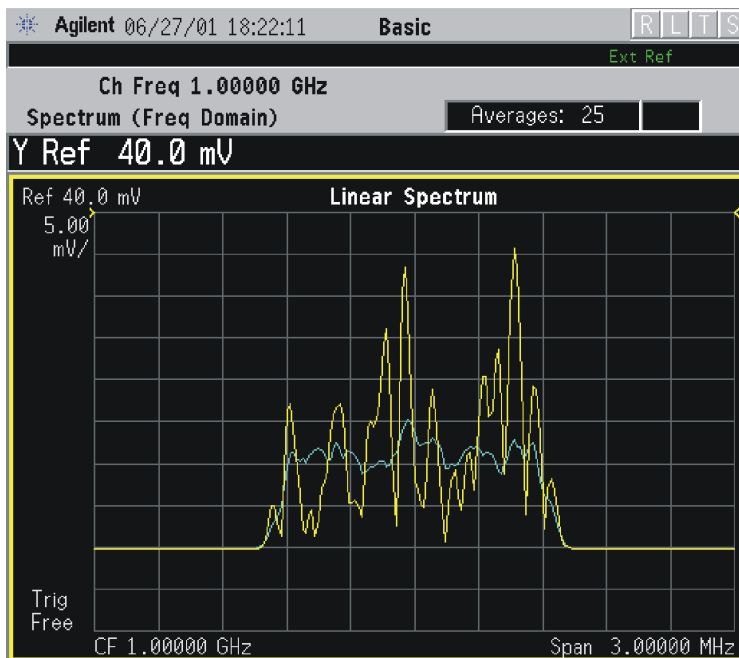

NOTE

(E4406A) For the widest spans, the I/Q window becomes just “ADC time domain samples”, because the I/Q down-conversion is no longer in effect. This is not the case for E4406A Option B7C if the **Input Port** is set to either **I/Q**, **I only**, or **Q only** and you have connected baseband I/Q signals to the **I/Q INPUT** connectors.

- **I and Q Waveform** - (for E4406A) Provides individual views of the I and Q signal waveform windows in parameters of voltage versus time.

To select the I or Q trace view, press the **Next** key at the bottom of the display. The selected window will have a green outline. To view the window full size press the **Zoom** key.

Figure 2-26 Spectrum Measurement - I and Q Waveform View (for E4406A)

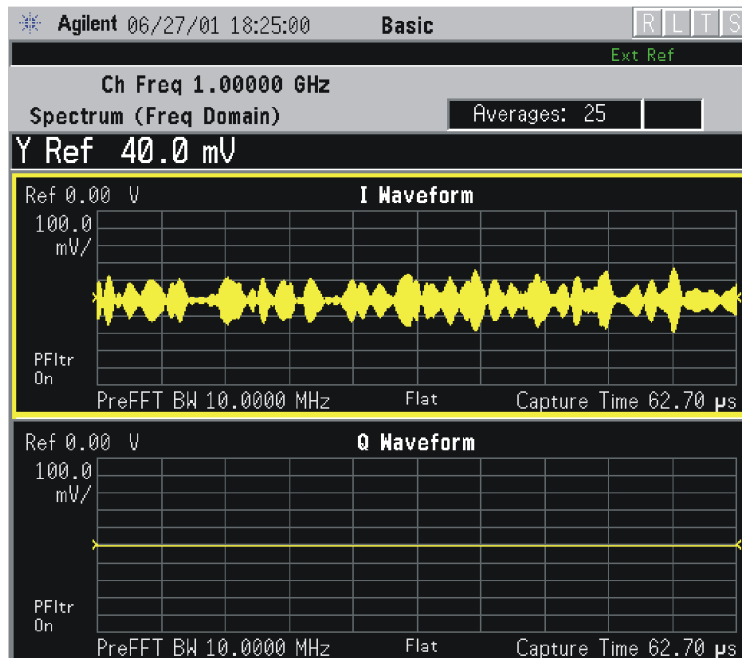
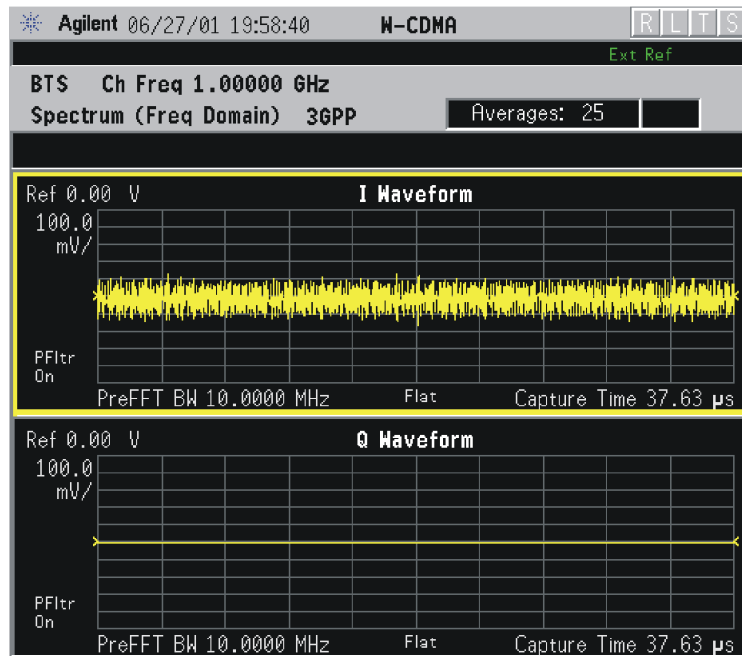

Figure 2-27 Spectrum Measurement - I and Q Waveform View (for E4406A)



*Meas Setup: View/Trace = I and Q Waveform,
Others = Factory default settings

*Input signals: - 10.00 dBm, PCCPCH + SCH

Figure 2-28 Spectrum Measurement - I and Q Waveform View (for E4406A)

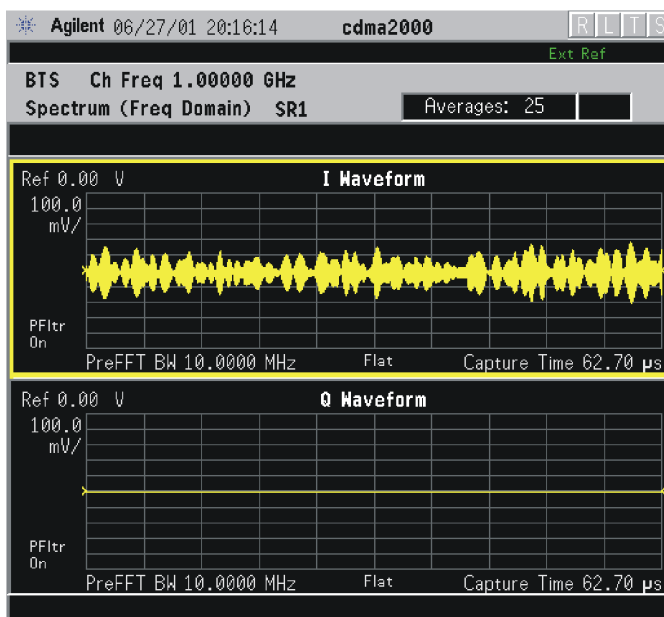

*Meas Setup: View/Trace = I and Q Waveform,
AMPLITUDE Y Scale = 5.00 mV,
Others = Factory default settings

*Input signals: - 10.00 dBm, 9 channels of SR1, cdma2000 Rev 8

Figure 2-29 Spectrum Measurement - I and Q Waveform View (for E4406A)

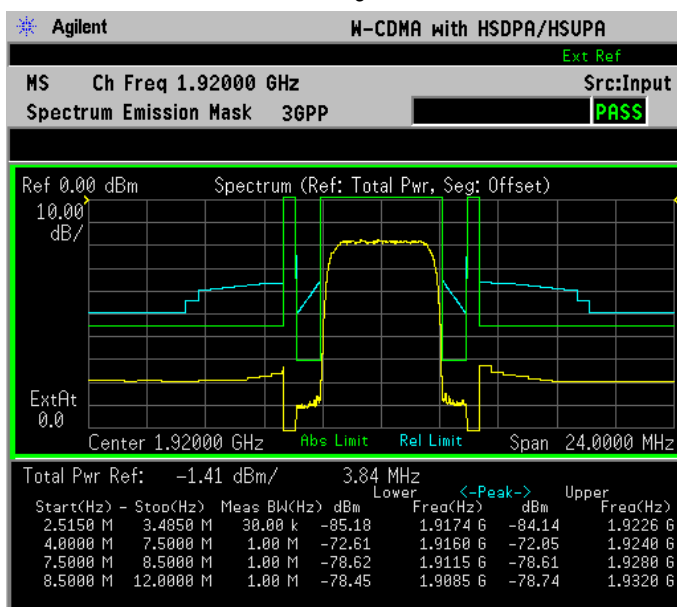

*Meas Setup: View/Trace = I and Q Waveform,
Others = Factory default settings

*Input signals: - 10.00 dBm, Pilot channel, 1xEV-DO

Figure 2-30 Spectrum Measurement - I and Q Waveform View (for E4406A)

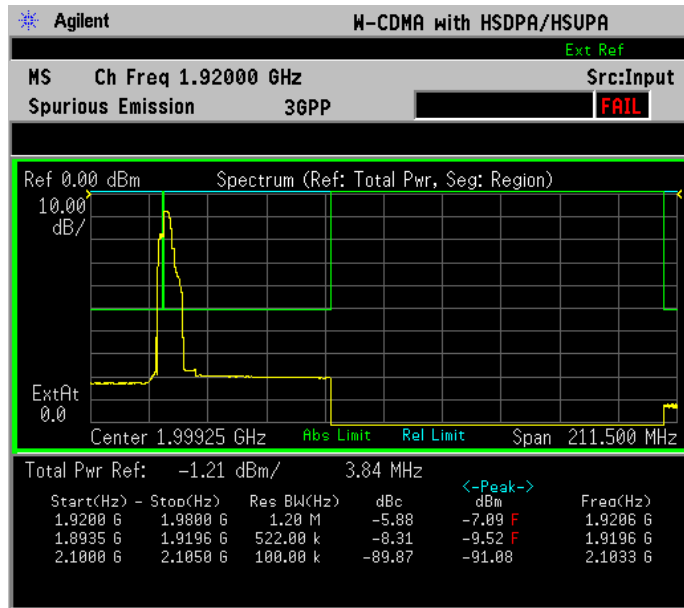

*Meas Setup: View/Trace = I and Q Waveform
Span = 500.000 kHz,
Y Scale/Div = 5.0 mV, Ref Value = 0.0 V,
Others = Factory default settings

*Input signals: -20.00 dBm, EDGE pattern data (PN9)

- **I/Q Polar** - (for E4406A) Provides a view of the I/Q signal displayed in a polar vector graph.

Figure 2-31 Spectrum Measurement - I/Q Polar View (for E4406A)

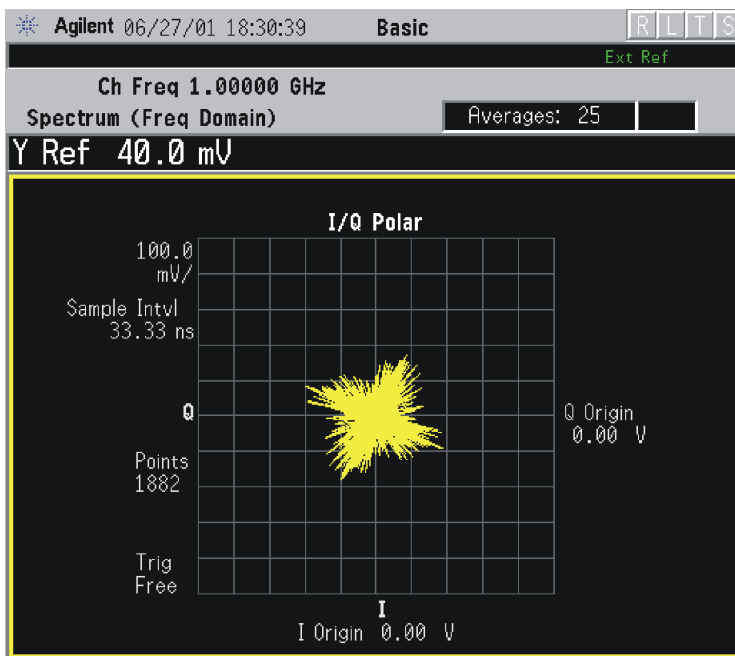
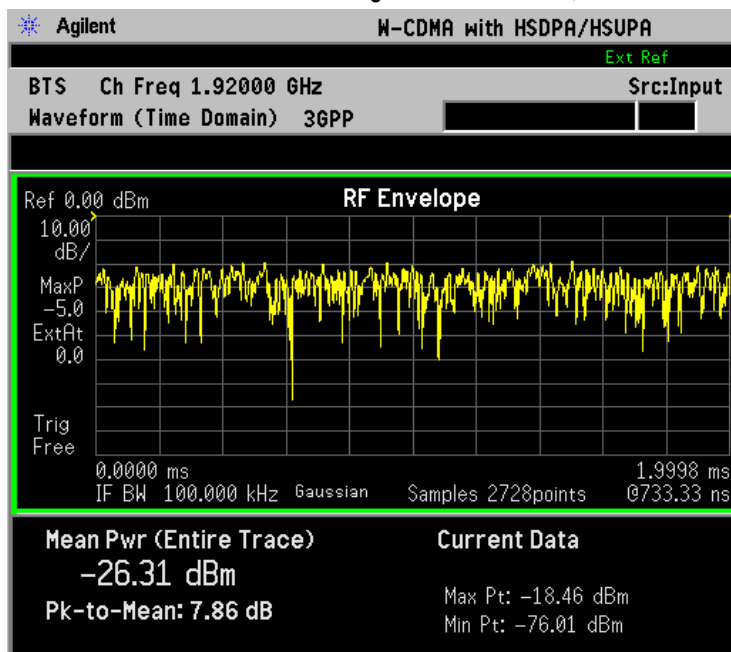

Figure 2-32 Spectrum Measurement - I/Q Polar View (for E4406A)



*Meas Setup: View/Trace = I/Q Polar,
Others = Factory default settings

*Input signals: - 10.00 dBm, PCCPCH + SCH

Figure 2-33 Spectrum Measurement - I/Q Polar View (for E4406A)

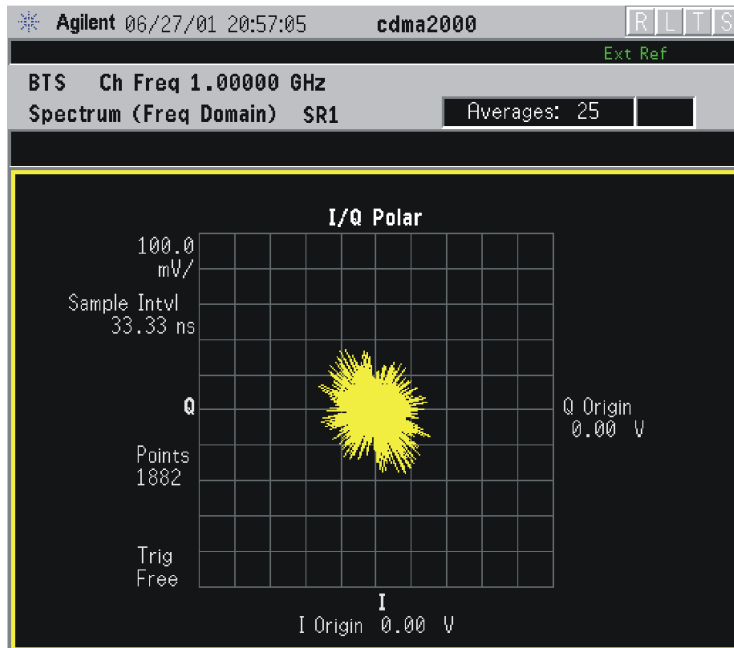

*Meas Setup: View/Trace = I/Q Polar,
Others = Factory default settings

*Input signals: - 10.00 dBm, Pilot channel of SR1, cdma2000 Rev 8

Figure 2-34 Spectrum Measurement - I/Q Polar View (for E4406A)

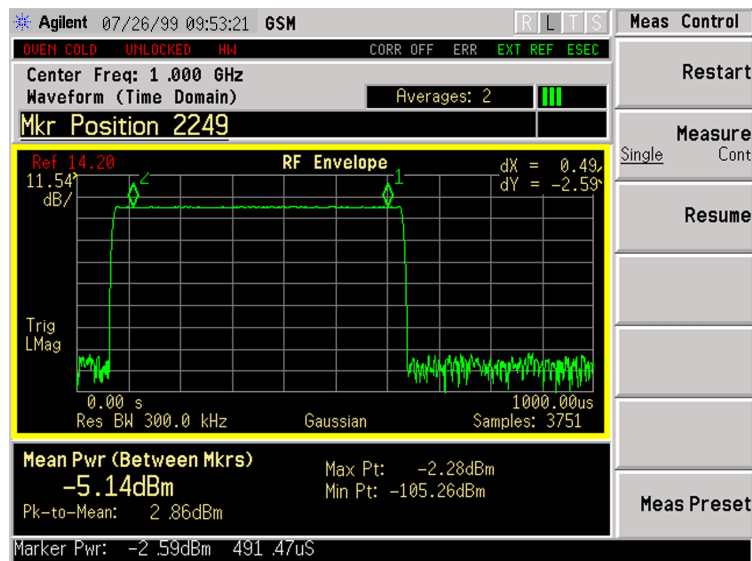

*Meas Setup: View/Trace = I/Q Polar,
Others = Factory default settings

*Input signals: - 10.00 dBm, Pilot channel, 1xEV-DO

Figure 2-35 Spectrum Measurement - I/Q Polar View (E4406A)

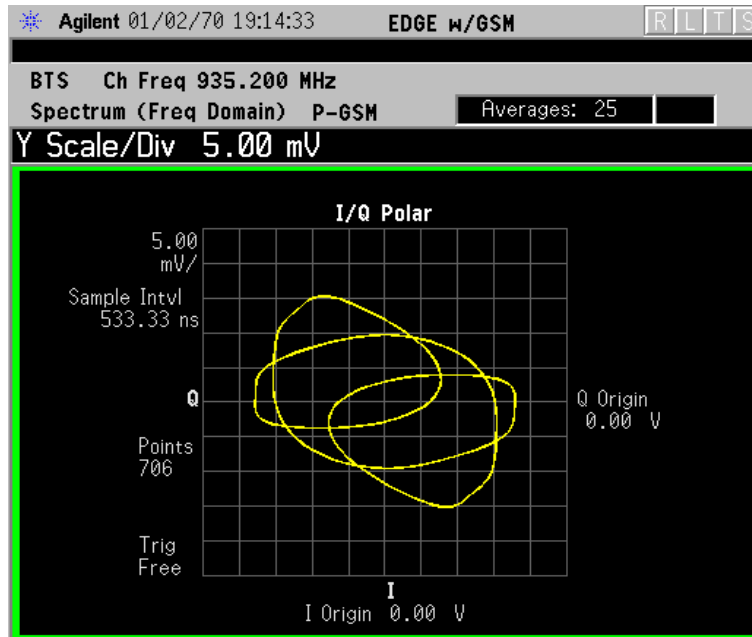

*Meas Setup: View/Trace = I/Q Polar
Span = 500.000 kHz,
Y Scale/Div = 5.0 mV, Ref Value = 0.0 V,
Others = Factory default settings

*Input signals: - 20.00 dBm, EDGE pattern data (PN9)

Step 7. To make a measurement repeatedly, press **Meas Control**, **Measure** to toggle the setting from **Single** to **Cont**.

Step 8. For PSA, if Option 122 or 140 is installed, you may use the wideband IF hardware to view a wide bandwidth signal in the Spectrum view. The I/Q Waveform view will be correctly demodulated to the I and Q components over the entire display bandwidth.

- Press **Mode**, and select **Basic** or **Modulation Analysis** to be able to use the Wideband IF path.
- Press **Measure**, and select the **Spectrum** measurement.
- Press **SPAN** and toggle the **IF Path** key to select **Wide**. Adjust the span to view up to 80 MHz for Option 122, or up to 40 MHz for Option 140 around your selected center frequency. Note the example below has 1 million data points.

The example shown below is a 54 carrier OFDM signal which has a -10 dB bandwidth greater than 16 MHz, with skirts to over twice that bandwidth. Delta markers are shown measuring the peak bandwidth.

Figure 2-36 Spectrum Measurement - Spectrum Zoom View with Opt. 122–80 MHz Bandwidth Digitizer Hardware

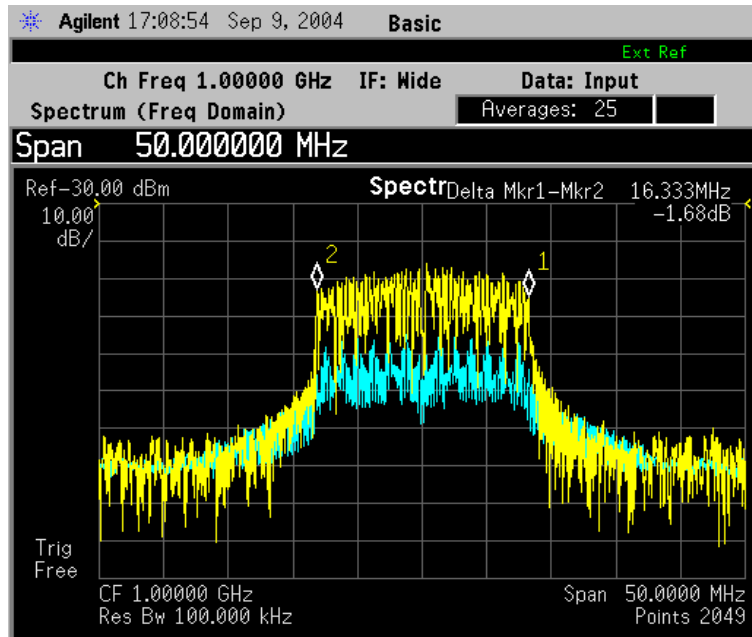

The example shown below is a 802.11 WLAN signal which has an instantaneous bandwidth of over 36 MHz. Only the Average trace is displayed.

When using the widest spans, the Resolution Bandwidth may be limited by the maximum number of points available for a Spectrum measurement. If your desired setting exceeds the available number of points, the maximum number available will be used, and an error message will be displayed.

Figure 2-37 Spectrum Measurement - Spectrum Zoom View with Opt. 122– 80 MHz Bandwidth Digitizer Hardware

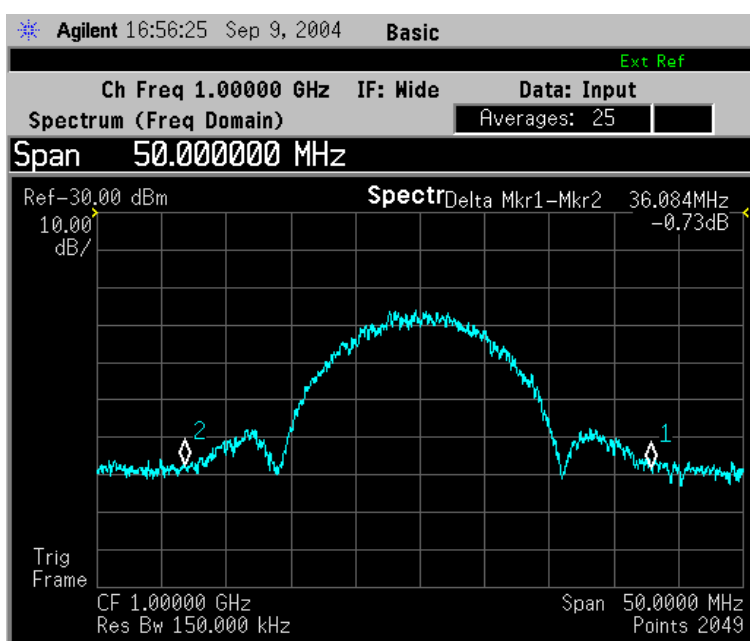

The example shown below is a Spectrum View of the center 20 MHz of a Noise Power Ratio measurement. If you extend the Span to the full 80 MHz bandwidth, individual carriers displayed may merge, as they can be limited by screen resolution and resolution bandwidth. Only the Average data trace is displayed in the example below.

Figure 2-38 Spectrum Measurement - Spectrum View with Opt. 122– 80 MHz Bandwidth Digitizer Hardware

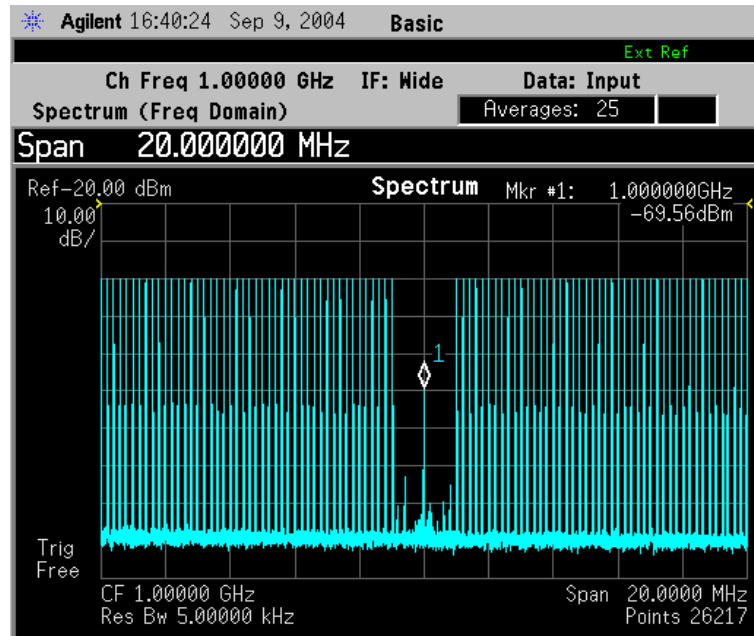

The wideband signal example shown below is 16 W-CDMA carriers, each occupying 5 MHz of bandwidth. The full 80 MHz of available demodulation bandwidth for the Spectrum measurement is used. Only the Average trace is displayed. Note the demodulated composite I/Q waveform for the entire 80 Mhz BW signal in the **I/Q Waveform** window below. A peak search marker has been applied to the composite waveform.

Figure 2-39 Spectrum Measurement - Spectrum Zoom View with Opt. 122– 80 MHz Bandwidth Digitizer Hardware

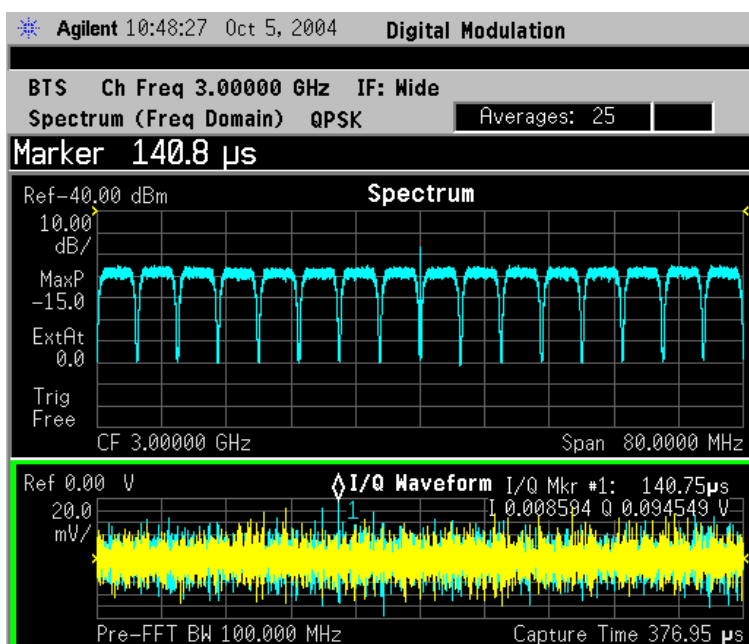

Step 9. Press the **Meas Setup, More (1 of 2)** keys to check the keys available to change the measurement parameters from the default condition.

For more details about using PSA Wide Bandwidth BW Digitizing Hardware Options 122 and 140, including detailed functional descriptions and SCPI commands and concepts, see the PSA Basic Mode Guide.

For more details about changing measurement parameters, see [“Spectrum \(Frequency Domain\) Measurement Concepts” on page 351.](#)

Waveform (Time Domain) Measurements

This section explains how to make waveform (time domain) measurement on a cdmaOne base station. Measurement of I and Q modulated waveforms in the time domain disclose the voltages which comprise the complex modulated waveform of a digital signal.

If installed, you may use PSA Option 122, the 80 MHz Bandwidth Digitizer hardware, or PSA Option 140, the 40 MHz Bandwidth Digitizer hardware to perform Waveform measurements of wideband signals using Basic Mode.

Configuring the Measurement System

The base station (BTS) under test has to be set to transmit the RF power remotely through the system controller. This transmitting signal is connected to the instruments RF input port. Connect the equipment as shown. An interfering or adjacent signal may supplied as shown.

Figure 2-40

Waveform Measurement System

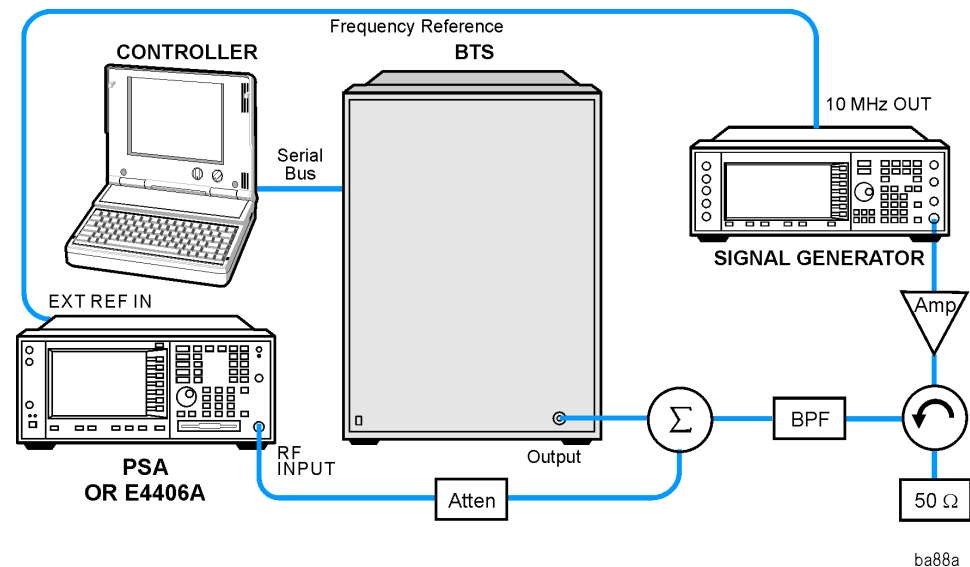

1. Using the appropriate cables, adapters, and circulator, connect the output signal of the BTS to the RF input of the instrument.
2. Connect the base transmission station simulator or signal generator to the BTS through a circulator to initiate a link constructed with sync and pilot channels, if required.
3. Connect a BNC cable between the 10 MHz OUT port of the signal generator and the EXT REF IN port of the instrument.
4. Connect the system controller to the BTS through the serial bus cable to control the BTS operation.

5. Connect an external trigger, if needed. Press Mode Setup, Trigger to access a menu to set up inputs and levels for all triggers. You must then select the appropriate trigger under the Meas Setup, Trigger menu to direct the measurement to use your trigger settings.

Setting the BTS

From the base transmission station simulator and the system controller, set up a call using loopback mode for the BTS to transmit the RF signal.

Measurement Procedure

- Step 1.** Press the **Preset** key to preset the instrument.
- Step 2.** Press the **MODE**, **cdmaOneBasic** keys to enable the **cdmaOneBasic Mode** measurements.
- Step 3.** To set the measurement center frequency press the **FREQUENCY Channel** key, enter a numerical frequency using the front-panel keypad, and complete the entry by selecting a units key, like **MHz**.
- Step 4.** Press the **SPAN** key, enter a numerical span using the front-panel keypad, and press the **MHz** key to set the measurement span in MHz.
- Step 5.** Press the **MEASURE** key to initiate the Waveform measurement.

The default display shows both **Current** (yellow trace) and **Average** (blue trace) data. To make viewing the display easier, you can view either the **Current** or **Average** trace separately.

- Press **Trace/View**, **Trace Display**, and select the trace(s) desired for display.

- Step 6.** Press **SPAN X Scale**, and the up or down arrow keys until the waveform is shown at a convenient time scale for viewing.

If installed, you may use the 80 MHz Bandwidth hardware to view a wideband signal in the RF Envelope view.

Press **SPAN** and select the **Wideband RF Path**. Adjust the span to view up to 80 MHz around your selected center frequency.

The next figure shows an example of an **RF Envelope** (key is called **Signal Envelope** on VSA) result for a waveform (time domain) measurement. The measured values for the mean power and peak-to-mean power are shown in the text window.

Figure 2-41 Waveform Measurement - RF Envelope (Default View)

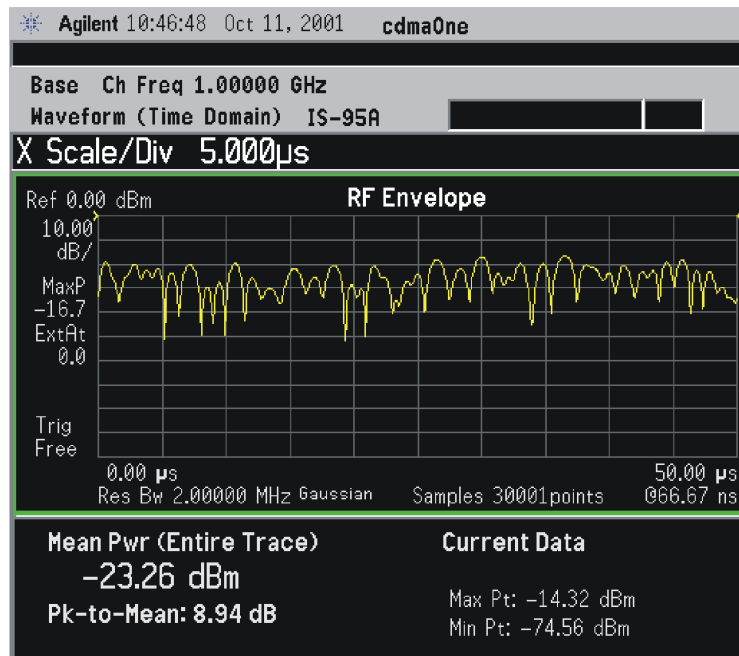
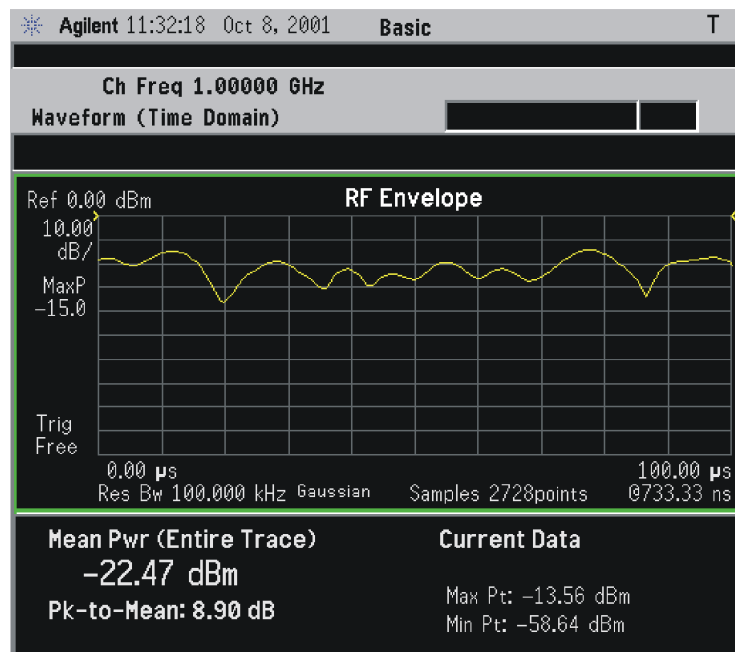

Figure 2-42 Waveform Measurement - RF Envelope (Default View)



*Meas Setup: Trace/View = RF Envelope,
Others = Factory default settings

*Input signal: cdma2000 Rev 8, SR1, 9 Channel

Step 7. Press the **Trace/View** (PSA) or **View/Trace** (E4406A) key to display the menu allowing selection of the other Waveform views, including the following:

- **Linear Envelope** - (for E4406A Option B7C) Provides a combination view of a linear signal envelope graph and a phase graph with linear graticules. Use the **Next Window** and **Zoom** keys to select and enlarge either graph.

Figure 2-43 Waveform Measurement - Linear Envelope View

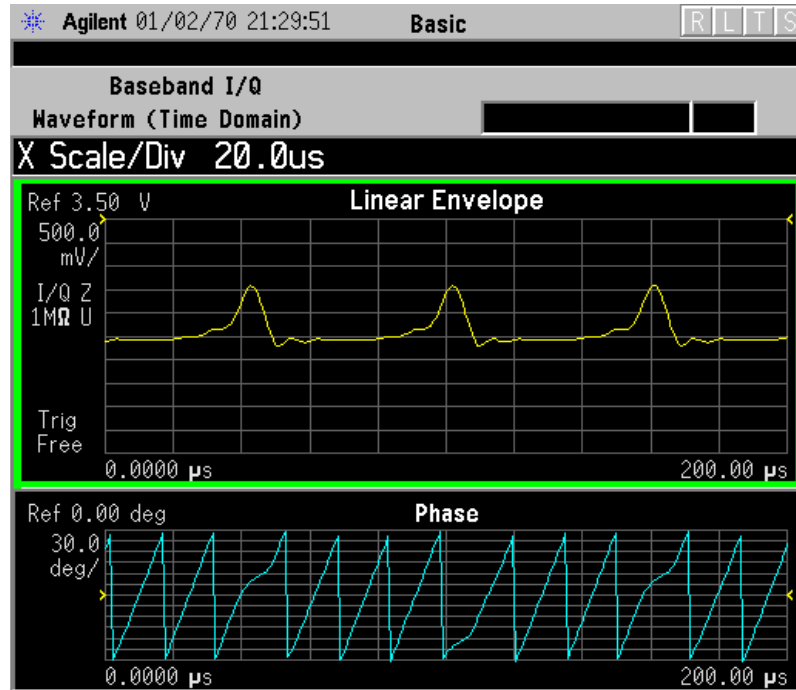

*Meas Setup: View/Trace = Linear Envelope View, GSM signal
Others = Factory defaults, except X and Y scales

- **I/Q Waveform** - Provides a view of the I and Q waveforms together on the same graph in parameters of voltage versus time in linear scale. Changes to the sweep time or resolution bandwidth can affect data acquisition.

Figure 2-44 Waveform Measurement - I/Q Waveform View

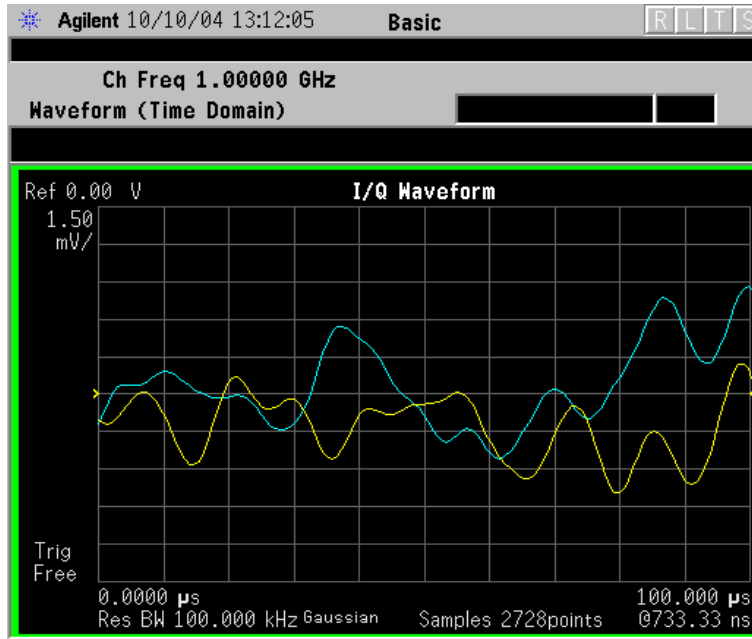
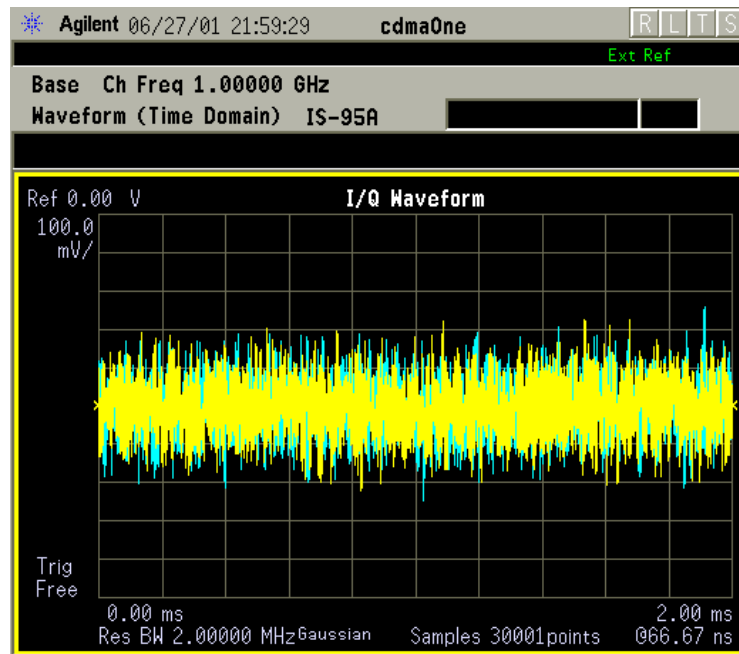

Figure 2-45 Waveform Measurement - I/Q Waveform View



*Meas Setup: View/Trace = I/Q Waveform View
Others = Factory defaults, except X and Y scales

NOTE

For the widest spans the I/Q Waveform window becomes just “ADC time domain samples”, because the I/Q down-conversion is no longer in effect.

Figure 2-46 I and Q Waveform - (for E4406A Option B7C) Provides a combination view of the I and Q signal waveform graphs in the linear scales.

Figure 2-47 Waveform Measurement - I and Q Waveform View

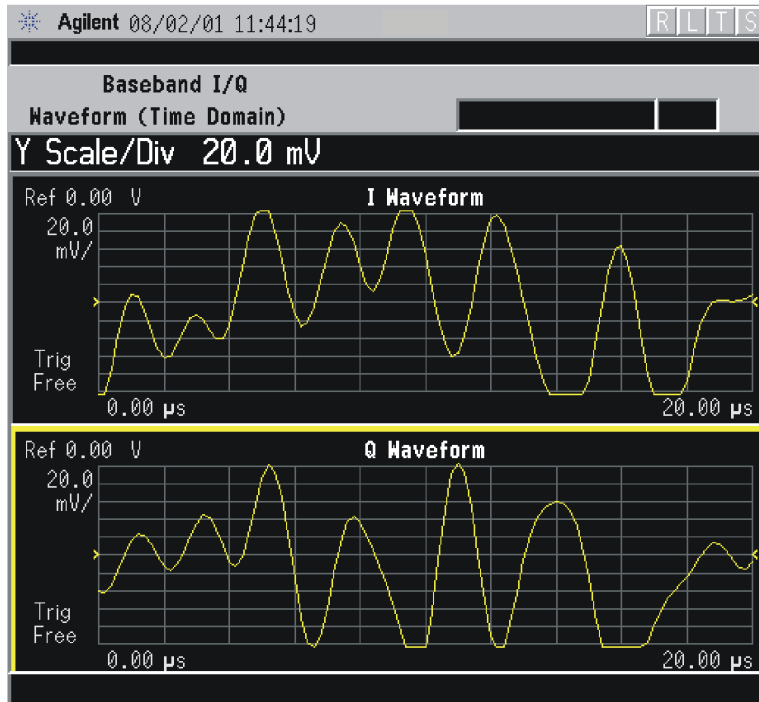

- **I/Q Polar** - (E4406A) Provides a view of the I/Q signal in a polar vector graph.

Figure 2-48 Waveform Measurement - I/Q Polar View

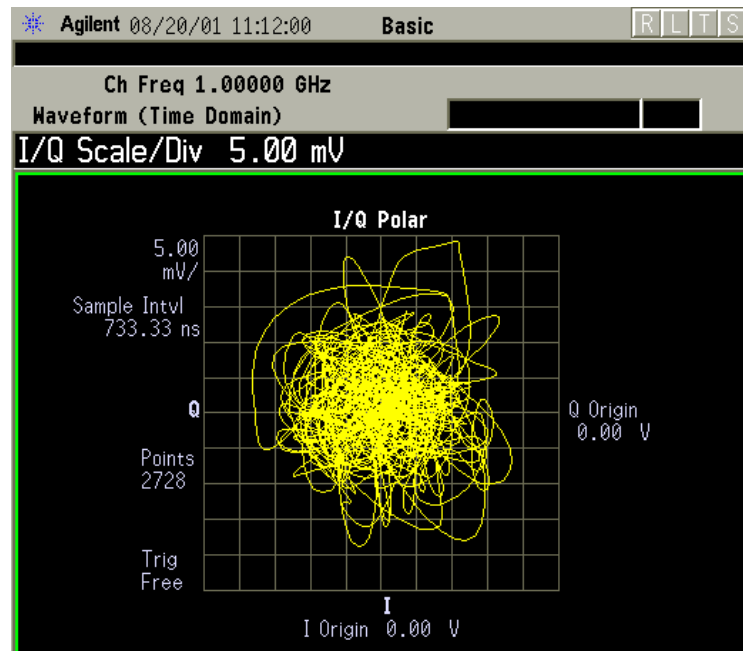

Figure 2-49 Waveform Measurement - I/Q Polar View

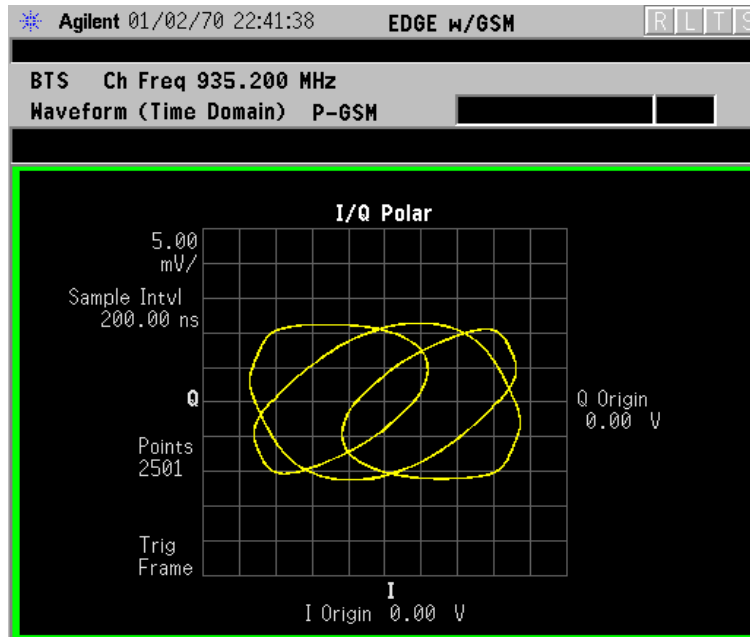
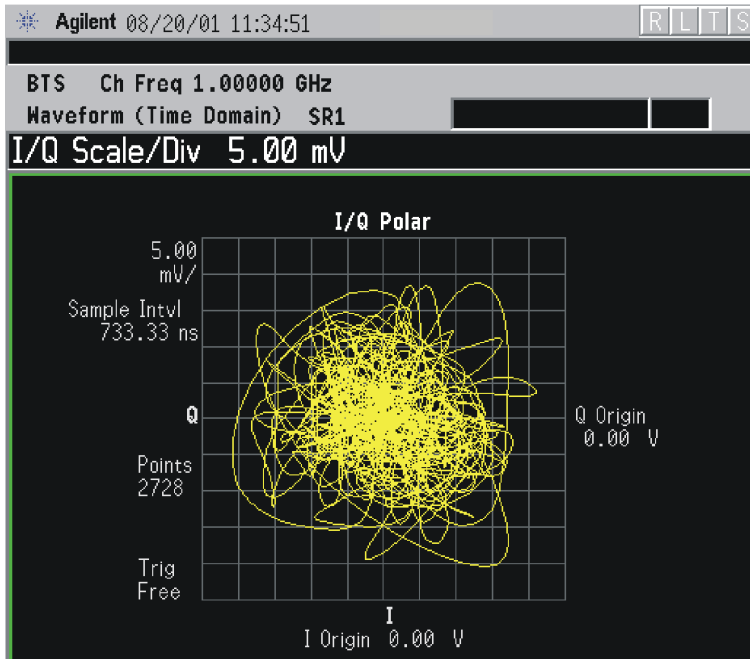

Figure 2-50 Waveform Measurement - I/Q Polar View



*Meas Setup: View/Trace = I/Q Polar View,
Others = Factory defaults, except X and Y scales

*Input signal: cdma2000 Rev 8, SR1, 9 Channel

Figure 2-51 Waveform Measurement - I/Q Polar View

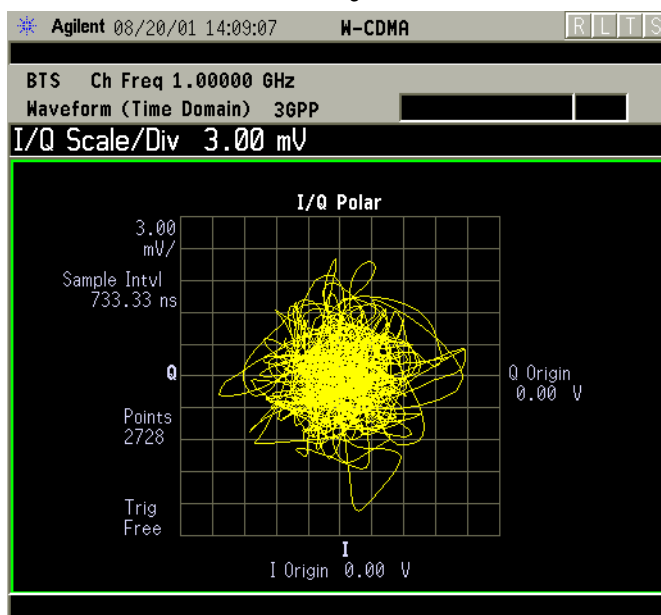

*Meas Setup: View/Trace = I/Q Polar View,
Others = Factory defaults, except X and Y scales

*Input signal: W-CDMA (3GPP 3.4 12-00), 1 DPCH,

Figure 2-52 Waveform Measurement - I/Q Polar View

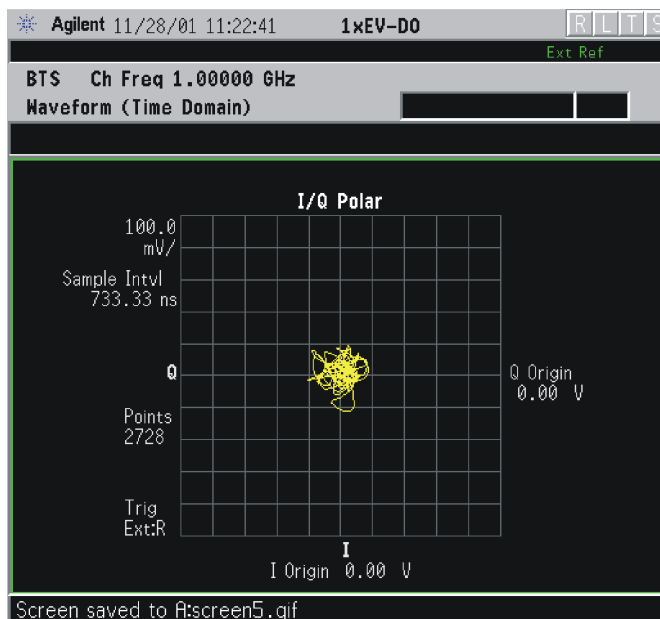

*Meas Setup: View/Trace = I/Q Polar,
Trigger Source = Ext Rear,
Others = Factory default settings

*Input signal: -10 dBm, Idle slot, 1xEV-DO

Step 8. If PSA Option 140 or 122 is installed, you may use the 40 or 80 MHz Bandwidth hardware to view a wideband signal in the Waveform view. Even if you are not interested in a wideband signal, using the Wideband IF path provides powerful measurement flexibility, including to the ability to accurately set practically any sample rate and thereby resample waveforms. Resampling, or oversampling, at the correct rate allows you to effectively obtain an integer number of samples per symbol. Make sure that the sample time is aligned with the decision points of the symbols to make analysis of measurement data much easier.

The following example of performing a Wideband IF Waveform measurement of a GSM burst will show the technique to accurately align and resample a signal:

- Press **Mode**, and select **Basic** or **Modulation Analysis** to be able to use the 80 MHz IF path.
- Press **Measure**, and select the **Waveform** measurement.
- Press **Trace/View** and select the **RF Envelope** view.
- Press **SPAN** and toggle the **IF Path** key to select **Wide**. Adjust the span to view up to 80 MHz around your selected center frequency. Note the example below has 1 million data points.

Figure 2-53 Waveform Measurement - RF Envelope View with Opt. 122– 80 MHz Bandwidth Digitizer Hardware

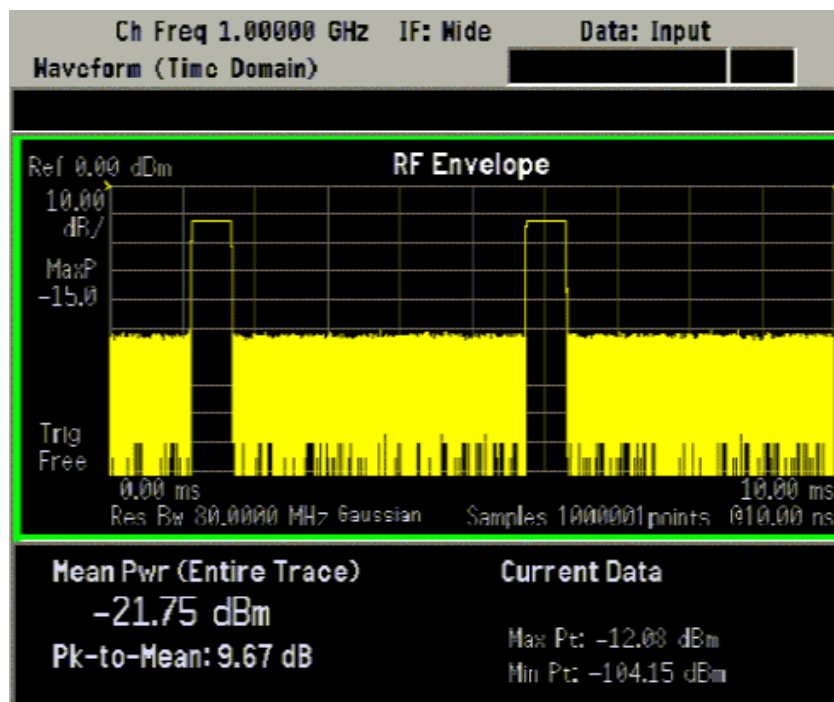

- Make sure that your samples are synchronized to the decision points of the signal of interest. In this case we will use the internal Frame Timer to trigger our measurement. A GSM frame is 4.615383 ms long.

Press **Mode Setup**, **Trigger**, select **Frame Timer**, then select **Period**. Enter 4.615383 ms. This only sets the frame timer period. You must direct the measurement to use the Frame Timer in the next step:

Press **Meas Setup**, **Trigger Source** and select **Frame**.

For other measurements, an external trigger may be applied to an External Trigger Input, on either the front or the rear panels. You must specify that trigger selection in this menu.

- In this example, we want to capture an entire GSM burst of 144 symbols (plus guard). A GSM burst is approximately 4.6 ms, so we will set our **Meas Time** to 5 ms:

Press **Meas Setup**, **Meas Time** and enter 5 ms.

- In this resampling example, we want to take exactly 10 samples per GSM symbol. The GSM symbol rate is 270.833 kHz, so we want a sample rate of 2.70833 MHz. Option 122 Wideband IF hardware lets us set the desired sample rate, as follows: $\text{sample rate} = 5/4 \text{ IF Bandwidth}$. That means we need set an IF BW of 2.16667 MHz.

Press **Meas Setup**, **IF BW** and enter 2.16667 MHz.

You can also access the sample rate key directly:

Press **Meas Setup**, **Wideband Setup**, and **Sample Rate** keys. Enter the **Sample Rate** frequency. The **Sample Rate** and **IF BW** settings are coupled. The 5/4 ratio will be preserved regardless of which setting is used.

- Your measurement result should look like [Figure 2-54](#)

Figure 2-54 Waveform Measurement - RF Envelope View with Opt. 122–80 MHz Bandwidth Digitizer Hardware

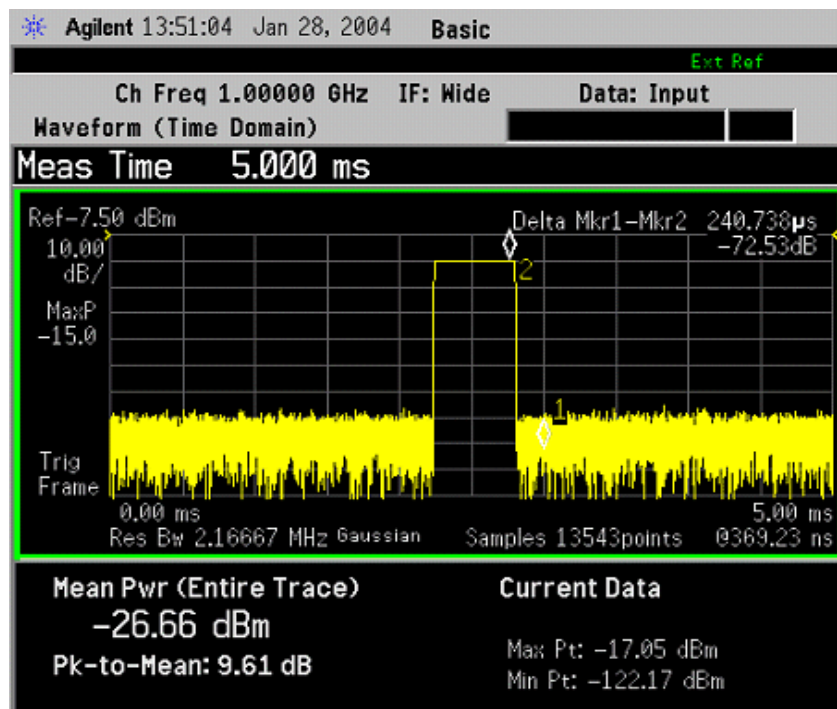

For more details about making wideband measurements, see “PSA Option 122 Wideband Digitizer” in the Option 122 section in the Basic Mode Guide.

- Step 9.** Press the **AMPLITUDE Y Scale**, and down arrow keys until the waveforms are shown at a convenient voltage scale for viewing.
- Step 10.** Press the **SPAN X Scale**, and down arrow keys until the waveforms are shown at a convenient time scale for viewing.
- Step 11.** Press the **Marker, Trace**, and **I/Q Waveform** keys to activate a marker. Rotate the RPG knob until the marker is shown at a desired time in the waveform for viewing the trace values at the time position of the marker.
- Step 12.** To make a measurement repeatedly, press **Meas Control, Measure** to toggle the setting from **Single** to **Cont**.
- Step 13.** Press the **Meas Setup, More (1 of 2)** keys to check the keys available to change the measurement parameters from the default condition.

Using the Waveform Measurement to Set Up Triggering (for burst signals)

You can use the waveform measurement to view your signal in the time domain and to help select the appropriate trigger to acquire your signal.

- Step 1.** Press **MEASURE, Waveform (Time Domain)** to activate the waveform measurement view.
- Step 2.** Press **SPAN X Scale, Scale/Div**, to adjust the scale of the x-axis to view the complete signal waveform. Use the front-panel keypad to input the scale/div, then press a units key, like μs , to complete the entry.
- Step 3.** Press **Meas Setup, Trig Source**, then select one of the available trigger sources (free run is the default setting).
- Step 4.** Press **Trig** or for E4406A press **Mode Setup, Trigger Setup**, then choose a trigger mode to set up the trigger conditions.

In the trigger mode set the delay, peak level and positive or negative edge slope trigger. You can also setup trigger holdoff, auto trigger timing and frame timer settings.

For more details about using PSA Option 122, 80 MHz BW Digitizing Hardware, and PSA Option 140, 40 MHz Digitizing Hardware, including detailed function descriptions, SCPI commands and concepts, see the PSA Basic Mode Guide.

For more details about changing measurement parameters, see [“Waveform \(Time Domain\) Measurement Concepts” on page 352](#).

Using Basic Mode

Basic mode is a standard feature of E4406A Transmitter Testers, and is part of Option B7J for the PSA Series Spectrum Analyzers. Basic mode is *not* related to a particular communications standard. That is, it does not default to measurement settings that are for any specific standard. You may want to use Basic Mode if you are making measurements on a signal that is not based on a specific digital communications standard.

Basic Mode in E4406A VSA Series Transmitter Testers

There are five generic measurements available under the **MEASURE** key in Basic mode:

- Adjacent Channel Power (ACP)
- Channel Power
- Power Statistics CCDF
- Spectrum Measurement (frequency domain).
- Waveform Measurement (time domain)

The ACP, Channel Power, and Power Stat CCDF measurements are fully described in the VSA Series User's Guide. Please refer to that manual for complete information on these measurements.

Spectrum and Waveform Measurements

These measurements provide a spectrum measurement mode that is similar to a standard spectrum analyzer, and a waveform measurement mode that is similar to a microwave oscilloscope. Unlike those standard analyzers, these measurements are optimized for digitally modulated signals, so they can be used to output the measured I/Q data.

For your convenience, Spectrum and Waveform measurements are also available in this mode, with the same functionality, so you can refer to the sections included in this chapter for information about using them.

Basic Mode in PSA Series Spectrum Analyzers

There are two generic measurements available under the **MEASURE** key in Basic mode:

- Spectrum Measurement (frequency domain).
- Waveform Measurement (time domain)
- Power Statistics CCDF

These Spectrum, Waveform, and CCDF measurements are also available in this mode, with the same functionality, so you can refer to the sections included in this chapter for information about using them.

If You Have a Problem

During the execution of your measurement you may encounter problems which generate error codes. Reference to the following common errors may be helpful.

If **Err** is shown in the annunciator bar, press the **System, Show Errors** hard and soft keys to read the detailed error information.

- **Error Code 16 “Input overload”**

This error means that your measurement has erroneous results due to the excessive input power level. To correct this condition, the input signal level must be reduced by using the internal and/or external attenuators.

Press the **Mode Setup, Input, Input Atten** keys to enter an attenuation value to reduce the transmitted power from the MS using the internal attenuator. The allowable range is up to 40 dB.

If you want to attenuate more than 40 dB, connect your external attenuator between the **RF INPUT** port and the UUT. Press the **Mode Setup, Input, Input Atten** and select **MS** or **BTS** keys to enter the attenuation value. The allowable range is up to ± 100 dB. The analyzer will automatically add its attenuation value to the readings of the measurement result.

To automate this calculation, press the **Mode Setup, Input, Ext Atten** keys to enter the additional attenuation value. The allowable range is up to 100 dB. The power readings of the measurement will take into account the external attenuation value.

- **Error Code 501 “Signal too noisy”**

This error means that your input signal is too noisy to capture the correct I/Q components. To make a more stable measurement the trigger source may need to be set to **Frame**, for example.

- **Error Code 503 “Can not correlate to input signal”**

This error means that the instrument has failed to find any active channels in the input signal as specified. To improve the correlation some critical parameter needs to be adjusted, like the input signal level or scramble code, for example.

For more details consult the chapter in this book dedicated to the measurement in question, or “Instrument Messages and Functional Tests.”

3 Key Reference

This chapter provides detailed descriptions of the keys used to set up and make cdmaOne measurements, including **Mode Setup**, **Meas Setup**, and **MEASURE**. Keys that allow you to see different presentations of the measurement results are also described, including **View/Trace**, and **Display**, showing the associated screens.

Front Panel Keys

NOTE

Only front panel keys affected by selection of cdmaOne mode are described here. For a complete description of all front panel keys see the E4406A VSA or PSA Series User's Guide.

FREQUENCY Channel Key Menu

Key Path: **FREQUENCY Channel**

- **Channel Number >** - Allows you to enter a channel value. This channel number and **Center Freq** are coupled together, then the frequency value automatically changes to the corresponding value for that channel number. The ranges are from 1 to 799 and 991 to 1023.
- **Center Freq** - Allows you to enter a frequency value. This center frequency and **Channel Number >** are coupled together, then the channel number automatically changes to the corresponding value for the specific frequency value in the ranges of 870.030 MHz to 893.970 MHz and 824.040 MHz to 835.000 MHz. This is the current instrument center frequency value. The overall frequency range without coupling function is 1.000 kHz to 4.32140 GHz.

FREQUENCY Channel Default Settings	
Channel Number >	799
Center Frequency	1.00000 GHz
PN Offset	0 × 64[chips]

Meas Control Key Menu

Key Path: **Meas Control**

- **Measure** - Press **Meas Control, Measure** (not to be confused with the front panel **MEASURE** key which has a different function) to toggle between Single and Cont (for continuous) measurement states. When set to Single, the measurement will continue until it has reached the specified number of averages set by the average counter. When set to Cont, the measurement will run continuously, and perform averaging according to the current average type (repeat or exponential). The default setting is continuous.
- **Pause** - Press **Meas Control, Pause** to pause the current measurement. Once toggled, the label of the **Pause** key changes to read **Resume**; the **Resume** key, once pressed, continues the active measurement from the point at which it was paused.

- **Restart** - Press **Restart** front panel key to repeat the current measurement from the beginning, while retaining the current measurement settings.

MODE Key Menu

Key Path: **MODE**

For PSA or E4406A:

To access the measurement personality that includes cdmaOne, press the **MODE** key and select the **cdmaOne** key.

NOTE

Mode settings are persistent. When you switch from one mode to another mode, the settings you have chosen for the modes will remain active until you change them. This allows you to switch back and forth between modes without having to reset settings each time. Presetting the instrument or powering the instrument off and on will return all mode settings to their default values.

Mode Setup Key Menu

Key Path: **Mode Setup**

- **Radio** key menu:
 - **Radio Std** - Select one of the radio standards to be tested:
 - IS-95A** - Sets to the standard of IS-95A system.
 - J-STD-008** - Sets to the standard of J-STD-008 system.
 - IS-97D IS-98D** - Sets to the standards of IS-97D and IS-98D systems.
 - **Band Class** - Select one of the band classes to be tested, when **Radio Std** is set to **IS-97D IS-98D**.
 - 0 (800MHz)** - Sets the band class to 0 for testing the North American and Korean cellular systems.
 - 1 (1900 MHz)** - Sets the band class to 1 for testing the North American PCS system.
 - 3 (JTACS)** - Sets the band class to 3 for testing the Japan TACS system.
 - 4 (Korean PCS)** - Sets the band class to 4 for testing the Korean PCS system.
 - **Device** - Select either **Base** or **Mobile** to be tested.

The following table lists the factory default settings for **Radio**.

Radio Default Settings	
Radio STD	IS-95A
Band Class (grayed out)	0 (800 MHz)
Device	Base

- **Input** key menu:

NOTE

You can also access the **Input** key from the **Input** front panel key.)

- **Input Port** - Allows you to access the menu to select one of the signal input ports as follows:
 - RF** - Allows you to measure an RF signal supplied to the front panel RF input port.
 - 50 MHz Ref** - (For E4406A) Allows you to measure the **50 MHz Reference** signal to calibrate the instrument.
 - Amptd Ref (f=50 MHz)** - (For PSA) Allows you to measure the 50 MHz reference signal to calibrate the instrument.
 - IF Align** - Allows you to configure the IF alignment signal. The RF path is switched to bring in the same alignment signal that is automatically switched to perform many alignments.
- **RF Input Range** - Allows you to toggle the RF input range control between **Auto** and **Man** (manual). If **Auto** is chosen, the instrument automatically sets the attenuation based on the carrier power level, where it is tuned. Once you change the **Max Total Pwr** or **RF Input Atten** value with the RPG knob, for example, the **RF Input Range** key is automatically set to **Man**. If there are multiple carriers present, the total power might overdrive the front end. In this case you need to set the **RF Input Range** to **Man** and enter the expected maximum total power by activating the **Max Total Pwr** key. **Man** is also useful to hold the input attenuation constant for the best relative power accuracy. For single carriers it is generally recommended to set this to **Auto**.
- **Max Total Pwr** - Allows you to set the maximum total power level from the UUT (Unit Under Test). The range is -200.00 to 100.00 dBm with 0.01 dB resolution. This is the expected maximum value of the mean carrier power referenced to the output of the UUT; it may include multiple carriers. The **Max Total Pwr** setting is coupled together with the **Input Atten** and **Ext Atten** settings. Once you change the **Max Total Pwr** value with the RPG knob, for example, the **Input Range** key is automatically set to **Man**.

- **Input Atten** - Allows you to control the internal input attenuator setting. The range is 0 to 40 dB with 1 dB resolution. The **Input Atten** key reads out the actual hardware value that is used for the current measurement. If more than one input attenuation value is used in a single measurement, the value used at the carrier frequency will be displayed. The **Input Atten** setting is coupled to the **Max Total Pwr** setting. Once you change the **Input Atten** setting with the RPG knob, for example, the **Input Range** key is automatically set to **Man**.
- **Ext RF Atten** - Allows you to access the following menu to enter the external attenuation values. Either of the **Ext RF Atten** settings is coupled together with the **RF Input Range** setting. However, pressing **Ext RF Atten** does not switch the **RF Input Range** key to **Man**. This will allow the instrument to display the measurement results referenced to the output of the UUT.
 - ❑ **MS** - Allows you to set an external attenuation value for MS tests. The range is – 50.00 to +50.00 dB with 0.01 dB resolution.
 - ❑ **BTS** - Allows you to set an external attenuation value for BTS tests. The range is – 50.00 to +50.00 dB with 0.01 dB resolution.
- **IF Align Signal** - Allows you to access the following menu to select one of the signals to be used for IF alignment.
 - ❑ **Signal Rate** - Allows you to set a value to be used for dividing the fundamental frequency of 468.75 kHz. The value ranges from 0 to 12 as the power of 2.
 - ❑ **Signal Amptd** - Allows you to set an amplitude value to be applied to the digital analog converter, for the IF alignment signal. The value ranges from 0 to 4095.
 - ❑ **Signal Type** - Allows you to access the following menu to select one of the signal types.
 - CW** - Sets the IF alignment signal to CW.
 - Comb** - Sets the IF alignment signal to comb wave.
 - Pulse** - Sets the IF alignment signal to pulse wave.

The following table lists the factory default setting for Input.

Input Default Settings	
Input Port	RF
RF Input Range	Auto ^a
Max Total Power	- 15.00 dBm ^b
Input Atten	0.00 dB ^b
Ext Atten Mobile Base	0.00 dB 0.00 dB
IF Align Signal Signal Rate Signal Amptd Signal Type	0 (= 468.75 kHz) DAC 500 CW

- a. Auto is not used for Spectrum (frequency domain) measurements.
- b. This may differ if the maximum input power is more than - 15.00 dBm, or depending on the previous measurements.

- **Trigger** key menu:

NOTE

These menus are used to set Trigger parameters only. The actual trigger source is selected separately for each measurement under the **Meas Setup** key.

- **RF Burst, Video (Envlp), Ext Front, Ext Rear-** Pressing one of these trigger keys will access each triggering condition setup menu. This menu is used to specify the **Delay**, **Level** and **Slope** settings for each trigger source as follows:

- Delay** - Allows you to enter a numerical value to modify the trigger delay time. The range is - 100.0 to +500.0 ms with 1 μ s resolution. For trigger delay use a positive value, and for pre-trigger use a negative value.
- Level** - Allows you to enter a numerical value to adjust the trigger level depending on the trigger source selected.

For **RF Burst**, the key label reads as **Peak Level**. The RF level range is - 25.00 to 0.00 dB with 0.01 dB resolution, relative to the peak RF signal level. The realistic range can be down to - 20 dB.

For **Video (Envlp)**, the video level range is – 200.00 to +50.00 dBm with 0.01 dB resolution at the RF input. The realistic range can be down to around – 50 dBm depending on the noise floor level of the input signal.

For **Ext Front** or **Ext Rear**, the level range is – 5.00 to +5.00 V with 1 or 10 mV resolution.

- Slope** - Allows you to toggle the trigger slope between **Pos** at the positive-going edge and **Neg** at the negative-going edge of the burst signal.
- **Trig Holdoff** - Allows you to set the period of time before the next trigger can occur. The range is 0.000 μ s to 500.0 ms with 1 μ s resolution.
- **Auto Trig** - Allows you to specify a time for a trigger timeout and toggle the auto trigger function between **On** and **Off**. The range is 1.000 ms to 1.000 ks with 1 μ s resolution. If no trigger occurs by the specified time, a trigger is automatically generated.
- **Frame Timer** - Allows you to access the menu to manually control the frame timer:
 - Period** - Allows you to set the period of the frame clock. The range is 0.000 ns to 559.0000 ms with 1 ps resolution.
 - Offset** - Allows you to set the offset of the frame clock. The range is 0.000 to 10.00 s with 100 ns resolution over 1.000 μ s range.
 - Reset Offset Display** - Allows you to display without any offset of the frame clock.
 - Sync Source** - Allows you to access the menu to select one of the sources to be synchronized with.
 - Off** - Allows you to turn the synchronizing source off for asynchronous tests.
 - RF Burst (Wideband)** - Allows you to select the RF burst signal as the synchronizing source.
 - Ext Front** - Allows you to select the external input signal from the front panel input port as the synchronizing source.
 - Ext Rear** - Allows you to select the external input signal from the rear panel input port as the synchronizing source.

Key Reference
Front Panel Keys

The trigger default settings are listed in the following table:

Trigger Default Settings	
RF Burst Delay Peak Level Slope	0.000 s – 6.00 dB Pos
Video (Envlp) Delay Level Slope	0.000 s – 6.00 dBm Pos
Ext Front Delay Level Slope	0.000 s 2.00 V Pos
Ext Rear Delay Level Slope	0.000 s 2.00 V Pos
Trig Holdoff	0.000 s
Auto Trig	100.0 ms; Off
Frame Timer Period Offset Reset Offset Display Sync Source	250.0 μ s 0.000 s (no parameter) Off

- Demod Key Menu
 - **Sync Type** - Allows you to select the type of synchronization used for the demodulation.
 - Even Sec** - Sets to synchronize to the internal frame timer that has been synchronized to an even second clock input. The frame timer has a 26.6667 ms period. This input signal is connected to the rear panel TRIGGER IN connecto
 - Pilot Seq** - Sets to synchronize to the pilot sequence on the RF channel. As this does not provide an absolute time reference, the measured time offset value will not be valid.
 - Ext Front** - Sets to directly synchronize to an external signal connected to the front panel EXT TRIGGER INPUT connector.
 - Ext Rear** - Sets to directly synchronize to an external signal connected to the rear panel TRIGGER IN connector.
 - None** - Sets to use no synchronization signal.

- **PN Offset** - Allows you to enter the PN offset of the base station being tested. This allows correct time offset values to be determined. This setting is not applicable when **Sync Type** is set to **Pilot Seq.**
- **RF Carrier** - Allows you to select **Single** if there is a single RF carrier present at the RF input signal, or **Multi** if there is more than one carrier present at the RF input signal which rejects the upper and lower adjacent channels for the modulation accuracy and code domain measurements.

The following table lists the factory default settings for the demodulation.

Demod Default Settings	
Sync Type	Even Sec (Rear Trig In)
PN Offset	0 × 64 [chips]
RF Carrier	Single

cdmaOne Measurement Keys

Adjacent Channel Power Ratio (ACPR) Keys

NOTE You must have selected ACPR at Key Path: **MEASURE** to access these menus.

Measurement Setup Key Menu

Key Path: **Meas Setup**

- **Avg Number** - Allows you to change the number of N averages.
- **Avg Mode** - Allows you to toggle the averaging mode between **Exp** (exponential) and **Repeat**. This selection only effects on the averaging result after the number of N averages is reached. The N is set using the **Avg Number** key.
 - **Normal averaging:** Normal (linear) averaging is always used until the specified number of N averages is reached. When the **Measure** key under **Meas Control** is set to **Single**, data acquisition is stopped when the number of N averages is reached, thus **Avg Mode** has no effect in the single measurement mode.
 - **Exponential averaging:** When **Measure** is set to **Cont**, data acquisition will continue indefinitely. Exponential averaging is used with a weighting factor of N (the displayed count of averages stops at N). Exponential averaging weights new data more heavily than old data, which allows tracking of slow-changing signals. The weighting factor N is set using the Avg Number key.
 - **Repeat averaging:** When **Measure** is set to **Cont**, data acquisition will continue indefinitely. After the number of N averages is reached, all previous result data is cleared and the average count displayed is set back to 1. This is equivalent to being in **Measure Single** and pressing the **Restart** key each time the single measurement finishes.
- **Ref Channel** - Allows you to access the following parameters for the reference channel settings:
 - **Chan Integ BW** - Allows you to specify the channel integration bandwidth in which the carrier power is measured. The range is 1.000 kHz to 20.0000 MHz with the best resolution of 1 Hz.
 - **Avg Type** - Allows you to set to power averaging type to either **Pwr Avg (RMS)** or **Maximum**.

- **Ref Chan Adv** - Allows you to access the menu to change the following advanced parameters for the reference channel:
 - ❑ **Sweep Time** - Allows you to toggle the sweep time function between **Auto** and **Man** (manual), and to set a value for the sweep time ranging from 1.0 ms to 50.000 ms if set to **Man**. If set to **Auto**, the reference channel measurement sweep time is derived from the data points and the number of FFT segments.
 - ❑ **Data Points** - Allows you to toggle the control function of the number of data points between **Auto** and **Man** (manual), and to set the number of data points ranging from 64 to 65536. The automatic mode chooses the optimum number of points ($= 2^{n+6}$ where $n = 0$ to 11) for the fastest measurement time with acceptable repeatability. The minimum number of points that could be used is determined by the sweep time and the sampling rate. You can increase the length of the measured time record (capture more of the burst) by increasing the number of points, but the measurement will take longer.
 - ❑ **Res BW** - This key is always grayed out. However, it allows you to see the resolution bandwidth that is derived from the combination of sweep time, data points, and FFT segments.
 - ❑ **Num FFT Seg** - Allows you to select the number of FFT segments used in making the measurement of the reference channel (carrier). In the automatic mode the measurement optimizes the number of FFT segments required for the shortest measurement time. The minimum number of segments required to make a measurement is set by your desired measurement bandwidth. Selecting more than the minimum number of segments will give you more dynamic range for making the measurement, but the measurement will take longer to execute.
- **Offset/Limits** - Allows you to access the menu to change the following parameters for offset frequency settings and pass/fail tests:
 - **Offset** - Allows you to select one of five offsets (**A** through **E**). Only one selection at a time (A, B, C, D, or E) is shown on this key label. The remaining softkeys on the **Offset/Limits** menu then apply to the selected offset.
 - **Offset Freq** - Allows you to enter an offset frequency value and toggle the offset function between **On** and **Off**. The range is 0.0 Hz to 45.000 MHz. While this key is activated, enter an offset value from the numeric keypad by terminating with one of the frequency unit keys shown. Offsets A and B are defaulted as follows for BS tests, while others are defaulted to 0.0 Hz and Off:

Offset A: 750.00765.00 kHz, On

Offset B: 1.98001.9950 MHz, On

Key Reference
cdmaOne Measurement Keys

One offset frequency center value corresponding to the **Offset** menu selection is shown on this key label. When **Radio** is set to **IS-97D IS-98D**, Offset to Edge considering the measurement bandwidth is shown in the measurement result window instead of Offset Freq for other radios as illustrated below.

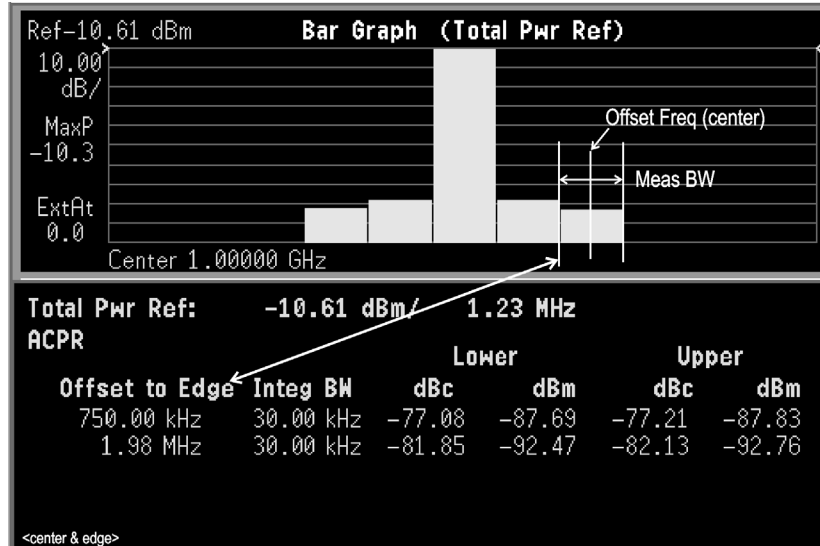

- **Offset Side** - Choose **Neg** (negative) or **Pos** (positive) to have single-sided offsets relative to the carrier, or **Both** (the default) to have offset frequency pairs.
- **Ref BW** - Allows you to enter a reference bandwidth ranging from 300 Hz to 20.0000 MHz with the best resolution of 1 Hz. When this parameter is changed, the integration bandwidth Integ BW in the summary data window changes to that value.
- **Avg Type** - Choose the type of averaging between **Pwr Avg (RMS)** or **Maximum**.
- **Limit Setup** - Allows you to access the menu to setup the limit values and conditions.
 - Abs Limit** - Allows you to enter an absolute limit value ranging from -200.00 to +50.00 dBm with 0.01 dB resolution.
 - Fail** - Allows you to access the following menu to select one of the logic keys for fail conditions between the measurement results and the test limits:
 - AND** - Fail is shown if one of the relative ACPR measurement results is larger than **Rel Lim (Car)** or **Rel Lim (PSD)** AND one of the absolute ACPR measurement results is larger than **Abs Limit**.

OR - Fail is shown if one of the relative ACPR measurement results is larger than **Rel Lim (Car)** or **Rel Lim (PSD)** OR one of the absolute ACPR measurement results is larger than **Abs Limit**.

Absolute - Fail is shown if one of the absolute ACPR measurement results is larger than **Abs Limit**.

Relative - Fail is shown if one of the relative ACPR measurement results is larger than **Rel Lim (Car)** or **Rel (PSD)**.

- Rel Lim (Car)**- Allows you to enter a relative limit value of the carrier level ranging from – 150.00 to +50.00 dBc with 0.01 dB resolution. The default is – 45.00 dBc for **Offset A** and – 60.00 dBc for **Offset B**.
- Rel Lim (PSD)**- Allows you to enter a relative limit value of the power spectral density level ranging from – 150.00 to +50.00 dB with 0.01 dB resolution. The default is – 28.87 dB for **Offset A** and – 43.87 dB for **Offset B**.
- **Offset Adv** - Allows you to access the menu to change the following advanced offset parameters:
 - Sweep Time** - Allows you to toggle the sweep time function between **Auto** and **Man** (manual), and to set a value for the sweep time ranging from 1.0 ms to 50.000 ms if set to **Man**. If set to **Auto**, the offset channel measurement sweep time is derived from the data points and the number of FFT segments.
 - Data Points** - Allows you to toggle the control function of the number of data points between **Auto** and **Man** (manual), and to set the number of data points ranging from 64 to 65536. If set to **Auto**, the optimum number of points ($= 2^{n+6}$ where $n = 0$ to 11) for the fastest measurement time with acceptable repeatability is automatically determined. The minimum number of points that could be used is determined by the sweep time and the sampling rate. You can increase the length of the measured time record (capture more of the burst) by increasing the number of points, but the measurement will take longer.
 - Res BW** - This key is always grayed out. However, it allows you to see the resolution bandwidth that is derived from the combination of sweep time, data points, and FFT segments.
 - Num FFT Seg** - The automatic mode selects the optimum number of FFT segments to measure the offset, while making the fastest possible measurement.

- ❑ **Relative Atten** - Allows you to set a relative amount of attenuation for the measurements made at your offsets. The amount of attenuation is always specified relative to the attenuation that is required to measure the carrier channel. Since the offset channel power is lower than the carrier channel power, less attenuation is required to measure the offset channel and you get wider dynamic range for the measurement.
- **Meas Type** - Allows you to access the menu to select one of the measurement reference types.
 - **Total Pwr Ref** - Sets the total carrier power to the measurement reference level and the measured data is shown in dBc and dBm.
 - **PSD Ref** - Select this to set the mean power spectral density of the carrier to the measurement reference level and the measured data is shown in dB and dBm/Hz.
- **Dynamic Range** - Allows you to optimize the dynamic range of the measurement in the following ways.
 - **Normal** - Select this to let the measurement automatically choose settings that trade off dynamic range for faster measurement speed. This is a good choice for making CDMA measurements on a signal with only one carrier turned on at a time.
 - **High** - Select this to choose settings that provide better dynamic range (better signal to noise ratio) at the expense of longer measurement time. This is a better choice for CDMA signals with multiple carriers turned on at the same time.
 - **Modified** - This is not a customer settable option. This choice is automatically selected depending on your selection of other related settings in the advanced measurement setup, like the number of FFT segments.
- **Fast ACPR** - Allows you to increase the speed of the measurement. A time domain computation method is used rather than an FFT transformation. When this faster measurement method is selected, repeatability is slightly reduced.
- **Spectrum Trace** - Turns off the spectrum trace data calculations. This is only applicable when using the Spectrum View. It speeds up the display of the other measured data values by not calculating the spectrum trace.
- **Limit Test** - Turns on or off the limit test function.
- **Restore Meas Defaults** - Allows you to preset only the settings that are specific to the selected measurement by pressing **Meas Setup, More (1 of 2), Restore Meas Defaults**. This will set the measure setup parameters, for the currently selected measurement only, to the factory defaults.

The next table shows the factory default settings for adjacent channel power ratio measurements.

Table 3-1 Adjacent Channel Power Ratio Measurement Defaults

Measurement Parameter	Factory Default Condition
View/Trace	Bar Graph (Total Pwr Ref)
Spectrum Trace	On
Avg Number	1520; On
Avg Mode	Repeat
Ref Channel:	
Chan Integ BW	1.23000 MHz
Avg Type	Pwr Avg (RMS)
Ref Chan Adv.:	
Sweep Time	546.1 μ s; Auto
Data Points	2048; Auto
Res BW	1.620 kHz (grayed out)
Num FFT Seg	1; Auto
Offset/Limits:	
Offset	A
Offset Freq	A: 750.000765.000 kHz; On B: 1.980001.99500 MHz; On
Offset Side	Both
Ref BW	30.000 kHz
Avg Type	Pwr Avg (RMS)
Limit Setup:	
Abs Limit	0.00 dBm
Fail	Relative
Rel Lim (Car)	A: - 45.00 dBc B: - 60.00 dBc
Rel Lim (PSD)	A: - 28.87 dB B: - 43.87 dB
Offset Adv.:	
Sweep Time	11.20 ms; Auto
Data Points	1024; Auto
Res BW	79.0 Hz (grayed out)
Num FFT Seg	1; Auto
Relative Atten	0.00 dB
Meas Type	Total Pwr Ref
Trig Source	Free Run (Immediate)
Fast ACPR	Off
Limit Test	On
Dynamic Range	Normal

View/Trace Key MenuKey Path: **View/Trace**

The **View/Trace** key accesses the menu to select either **Bar Graph** or **Spectrum** for the measurement result, depending on the **Sweep Type** setting.

- **Bar Graph** - In the factory default condition 5 of the total integration power levels, centered at the carrier frequency and ± 765.0 kHz and ± 1.995 MHz offset frequencies, are shown in the figure for the “Results” section. The corresponding measured data is shown in the text window. When **Radio** is set to **IS-97D IS-98D**, Offset to Edge considering the measurement bandwidth is shown in the measurement result window instead of Offset Freq for other radios. Depending on the **Meas Type** selection, one of the two following displays is obtained:

Bar Graph (Total Pwr Ref) - A histogram of powers referenced to the total power

Bar Graph (PSD Ref) - A histogram of powers referenced to the mean power spectral density of the carrier in dBm/Hz

- **Spectrum** - In the factory default condition, the frequency spectrum with the FFT sweep type is displayed with the bandwidth marker lines in the graph window. The corresponding measured data in the text window is the total integration power levels, in dBc and dBm, within the defined bandwidth as shown in the figure below.

Figure 3-1**ACPR Measurement - Spectrum View**

Figure 3-2 ACP Measurement - Spectrum View



Depending on the **Meas Type** setting, one of the two following displays is obtained:

Spectrum (Total Pwr Ref) - A spectrum display referenced to the total power

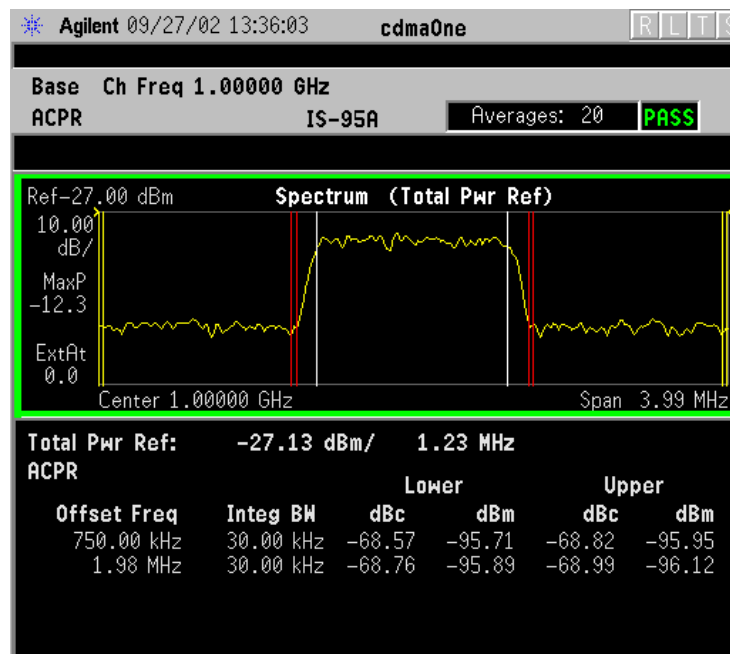
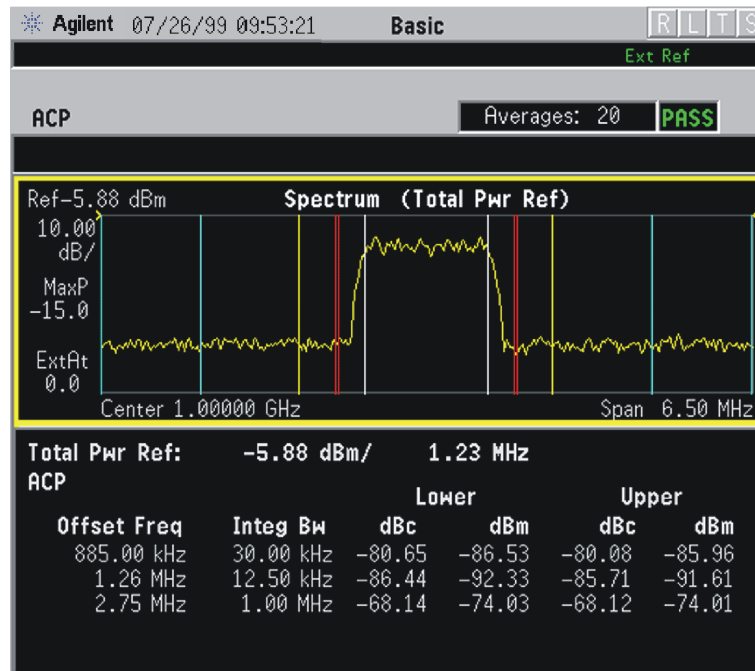
Spectrum (PSD Ref) - A spectrum display referenced to the mean power spectral density of the carrier in dBm/Hz

You can improve the update speed of the displayed data values by turning off the spectrum trace in **Meas Setup**.

Marker Key Menu

The **Marker** key is not available for this measurement function.

Channel Power Keys

NOTE You must have selected Channel Power at Key Path: **MEASURE** to use these menus.

Measurement Setup Key Menu

Key Path: **Meas Setup**

- **Avg Number** - Allows you to change the number of N averages.
- **Avg Mode** - Allows you to toggle the averaging mode between **Exp** (exponential) and **Repeat**. This selection only effects on the averaging result after the number of N averages is reached. The N is set using the **Avg Number** key.
 - **Normal averaging**: Normal (linear) averaging is always used until the specified number of N averages is reached. When the **Measure** key under **Meas Control** is set to **Single**, data acquisition is stopped when the number of N averages is reached, thus **Avg Mode** has no effect in the single measurement mode.
 - **Exponential averaging**: When **Measure** is set to **Cont**, data acquisition will continue indefinitely. Exponential averaging is used with a weighting factor of N (the displayed count of averages stops at N). Exponential averaging weights new data more heavily than old data, which allows tracking of slow-changing signals. The weighting factor N is set using the Avg Number key.
 - **Repeat averaging**: When **Measure** is set to **Cont**, data acquisition will continue indefinitely. After the number of N averages is reached, all previous result data is cleared and the average count displayed is set back to 1. This is equivalent to being in **Measure Single** and pressing the **Restart** key each time the single measurement finishes.
- **Integ BW** - Allows you to specify the integration bandwidth in which the power is measured. The range is 1.000 kHz to 10.0000 MHz with 1 Hz resolution. Since **Integ BW** is coupled to **Chan Power Span** in the factory default condition, if you change the integration bandwidth setting, the channel power span setting changes by a proportional amount, 1.2 times the integration bandwidth, until a limit value is reached.
- **Chan Power Span** - Allows you to set the frequency span for the channel power measurement. The range is 1.000 kHz to 10.0000 MHz with 1 Hz resolution. This span is used for the current integration bandwidth setting. Since **Chan Power Span** is coupled to **Integ BW** in the factory default condition, if you change the integration bandwidth setting, the channel power span setting changes by a proportional amount, 1.2 times the integration bandwidth, until a limit value is reached. However, the channel

power span can be individually set.

- **Restore Meas Defaults** - Allows you to preset only the settings that are specific to the selected measurement by pressing **Meas Setup, More (1 of 2), Restore Meas Defaults**. This will set the measure setup parameters, for the currently selected measurement only, to the factory defaults.
- **Advanced** - Allows you to access the following menu to modify the channel power measurement parameters:

NOTE

Parameters under the **Advanced** key seldom need to be changed. Any changes from the factory default values may result in invalid measurement data.

- **Sweep Time** - Allows you to manually change the sweep time and also to toggle the sweep time control between **Auto** and **Man** (manual). The range is 1.0 μ s to 50.00 ms with 1 μ s resolution. If set to **Auto**, the sweep time derived from the data point setting is shown on this key regardless of the manual entry range.
- **Data Points** - Allows you to select the number of data points and also to toggle the data point control between **Auto** and **Man** (manual). The range is 64 to 65536 with the acceptable entry in powers of 2 (for example: 64, 128, 512). If set to **Auto**, the optimum number of points is determined for the fastest measurement time with acceptable repeatability. The minimum number of points that could be used is determined by the sweep time and the sampling rate. You can increase the length of the measured time record (capture more of the burst) by increasing the number of points, but the measurement will take longer.
- **Res BW** - Shows information on the resolution bandwidth derived from the sweep time. This key is always grayed out.
- **Trig Source** - Allows you to choose a trigger source from **Free Run (Immediate)**, **Video (Envlp)**, **RF Burst (Wideband)**, **Ext Front**, **Ext Rear**, **Frame**, **I/Q Input**, or **Line**.

The next table shows the factory default settings for channel power measurements.

Table 3-2 Channel Power Measurement Defaults

Measurement Parameter	Factory Default Condition
Meas Setup:	
Avg Number	200; On
Avg Mode	Repeat
Integ BW ^a	5.00000 MHz
Chan Power Span ^a	6.00000 MHz
Advanced	
Sweep Time	68.27 μ s; Auto
Data Points	2048; Auto
Res BW (grayed out)	27.857 kHz (grayed out)
Trig Source	Free Run (Immediate)

a. The Integ BW setting proportionally changes the Chan Power Span setting up to 10 MHz.

AMPLITUDE Y Scale Key Menu

Key Path: **AMPLITUDE Y Scale**

The **AMPLITUDE Y Scale** key accesses the menu to set the desired vertical scale and associated settings:

- **Scale/Div** - Allows you to enter a numeric value to change the vertical display sensitivity. The range is 0.10 to 20.00 dB with 0.01 dB resolution. The default setting is 10.00 dB. However, since the **Scale Coupling** default is **On**, this value is automatically determined by the measurement result. When you set a value manually, **Scale Coupling** automatically changes to **Off**.
- **Ref Value** - Allows you to set the absolute power reference value ranging from -250.00 to 250.00 dBm with 0.01 dB resolution. The default setting is 10.00 dBm. However, since the **Scale Coupling** default is **On**, this value is automatically determined by the measurement result. When you set a value manually, **Scale Coupling** automatically changes to **Off**.
- **Ref Position** - Allows you to set the display reference position to either **Top**, **Ctr** (center), or **Bot** (bottom). The default setting is **Top**.
- **Scale Coupling** - Allows you to toggle the scale coupling function between **On** and **Off**. The default setting is **On**. Upon pressing the **Restart** front-panel key or **Restart** softkey under the **Meas Control** menu, the scale coupling function automatically determines the scale per division and reference values based on the measurement

results. When you set a value to either **Scale/Div** or **Ref Value** manually, **Scale Coupling** automatically changes to **Off**.

Marker Key Menu

The **Marker** key is not available for this measurement function.

Code Domain Keys (Base Station Only)

NOTE

Make sure the Code Domain measurement is selected under the **MEASURE** menu.

Meas Setup Key Menu

Key Path: **Meas Setup**

- **Avg Mode** - Allows you to choose either exponential or repeat averaging. This selection only effects the averaging after the number of N averages is reached (set using **Avg Number**).
 - **Normal averaging:** Normal (linear) averaging is always used until the specified number of N averages is reached. When **Measure** is set to **Single**, data acquisitions are stopped when the number of averages is reached - thus **Avg Mode** has no effect on single measurements.
 - **Exponential averaging:** When **Measure** is set at **Cont**, data acquisitions will continue indefinitely. After N averages, exponential averaging is used with a weighting factor of N (the displayed average count stops at N). Exponential averaging weights new data more than old data, which allows tracking of slow-changing signals. The weighting factor N is set using **Avg Number**.
 - **Repeat averaging:** When **Measure** is set at **Cont**, data acquisitions will continue indefinitely. After N averages is reached, all previous result data is cleared and the average count is set back to 1. This is equivalent to being in **Single** for **Measure** and pressing the **Restart** key each time the single measurement finishes.
- **Meas Intvl** - Allows you to set the time interval over which the measurement is made.
- **Meas Method** - Allows you to access the following menu:
 - **Power** - Sets to measure and display code domain power (fastest).
 - **Timing Phase** - Sets to measure and display code domain power, timing, and phase in the individual graph windows.
- **Active Set Th** -Allows you to set the relative power level used to separate active traffic channels from inactive traffic channels.

- **Spectrum** - This key, when set to **Invert**, conjugates the spectrum, which equivalently negates the quadrature component in demodulation. The correct setting (**Normal** or **Invert**) depends on whether the signal being input to the instrument has a high or low side mix.
- **Demod** - Defines the demodulation method such as synchronization signal, PN offset, and RF carrier selection.
 - **Sync Type** - Selects the type of synchronization used for the demodulation.
 - Even Sec (Rear Trig In)** - Synchronizes to the internal frame timer that has been synchronized to an even second clock input. The frame timer has a 26.6667 ms period. This input signal is connected to the rear panel TRIGGER IN connector.
 - Pilot Seq** - Synchronizes to the pilot sequence on the RF channel. As this does not provide an absolute time reference, the measured time offset value will not be valid.
 - Ext Front (Front Trig In)** - Directly synchronizes to an external signal connected to the front panel EXT TRIGGER INPUT connector.
 - Ext Rear (Rear Trig In)** - Directly synchronizes to an external signal connected to the rear panel TRIGGER IN connector.
 - None** - No synchronization is made.
 - **PN Offset** - Used to enter the PN offset of the base station being tested. This allows correct time offset values to be determined. This setting is not applicable when **Sync Type** is set to **Pilot Seq**.
 - **RF Carrier** - Select **Single** if there is a single RF carrier present at the RF input signal. Select **Multi** if there is more than one carrier present at the RF input signal, which rejects the upper and lower adjacent channels for the modulation accuracy and code domain measurements.
- **Restore Meas Defaults** - Press Meas Setup, More, Restore Meas Defaults to preset only the settings that are specific to the selected measurement. This will set the measure setup parameters, for the currently selected measurement only, to the factory defaults.

Table 3-3 Code Domain Measurement Defaults

Measurement Parameter	Factory Default Condition
View/Trace	Power Graph & Metrics
Display Points/Chip	2
Avg Frames	10; On
Avg Mode	Repeat
Meas Interval	1.250 ms
Meas Method	Power
Active Set Th	- 20.00 dB
Spectrum	Normal
Demod	
Sync Type	Even Sec (Rear Trig In)
PN Offset	0 × 64[chip]
RF Carrier	Single

View/Trace Key Menu

Key Path: **View/Trace**

- **Power Graph & Metrics** - Provides a combination view of the code domain power graph and the numeric result summary.
- **Power Graph & Markers** - Provides a combination view of the code domain power graph with the marker and the numeric results measured at those marker points up to four.

Figure 3-3

Code Domain Measurement - Power Graph and Markers View

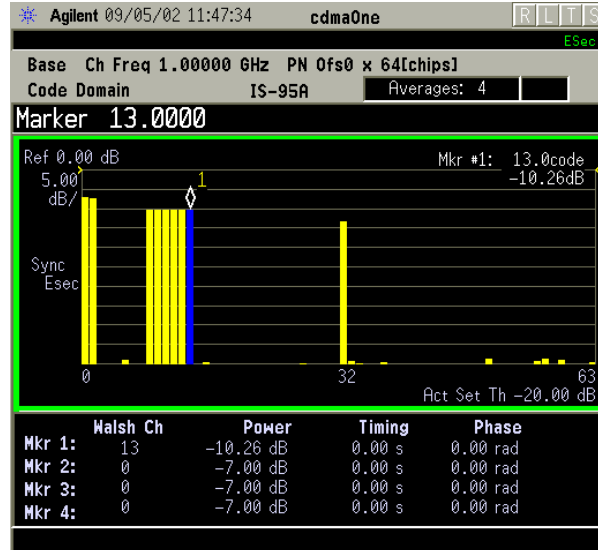

- **Power Timing & Phase** - Provides a combination view of code domain power, timing, and phase graphs.

Figure 3-4

Code Domain Measurement - Power, Timing, and Phase View

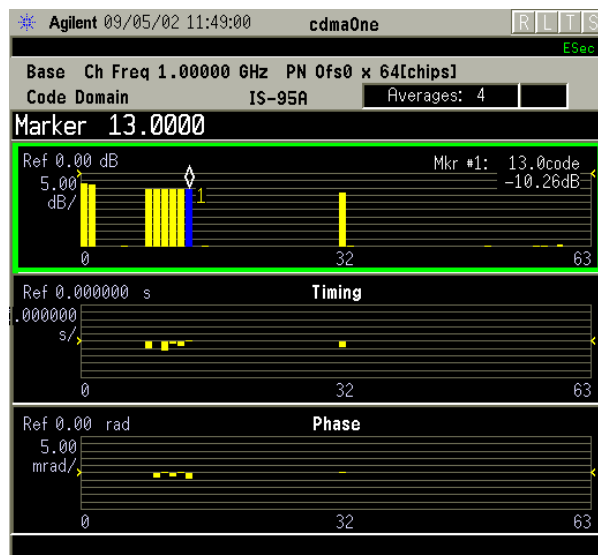

Display Key Menu

Key Path: **Display**

- **Points/Chip** - Allows you to set the number of sample points displayed per chip to either 2, 4, or 8. The default selection is 2.

NOTE The following additional keys become active for **Power Graph & Metrics**, **Power Graph & Markers**, or **Power Timing & Phase** view when the Power window is active.

- **AMPLITUDE Y Scale**

- **Scale/Div** - Allows you to set the vertical scale by changing the value per division. The range is 0.10 to 20.00 dB. The default setting is 5.00 dB. However, since **Scale Coupling** default is **On**, this value is automatically determined by the measurement result. When you set a value manually, **Scale Coupling** automatically changes to **Off**.
- **Ref Value** - Allows you to set the reference value ranging from – 250.00 to 250.00 dB. The default setting is 0.00 dB. However, since **Scale Coupling** default is **On**, this value is automatically determined by the measurement results. When you set a value manually, **Scale Coupling** automatically changes to **Off**.
- **Ref Position** - Allows you to set the reference position to either **Top**, **Ctr** (center) or **Bot** (bottom). The default setting is **Top**.
- **Scale Coupling** - Allows you to toggle the scale coupling function between **On** and **Off**. The default setting is **On**. Upon pressing the **Restart** front panel key or the **Restart** softkey under the **Meas Control** menu, this function automatically determines the scale per division and reference values based on the measurement results. When you set a value to either **Scale/Div** or **Ref Value** manually, **Scale Coupling** automatically changes to **Off**.

NOTE The following additional keys become active for **Power Timing & Phase** view when the Timing window is active.

- **AMPLITUDE Y Scale**

- **Scale/Div** - Allows you to set the vertical scale by changing the value per division. The range is 0.10 to 20.00 dB per division. The default setting is 5.00 dB. However, since **Scale Coupling** default is **On**, this value is automatically determined by the measurement result. When you set a value manually, **Scale Coupling** automatically changes to **Off**.
- **Ref Value** - Allows you to set the reference value ranging from – 250.00 to 250.0 dB. The default setting is 0.00 dB. However, since **Scale Coupling** default is **On**, this value is automatically determined by the measurement results. When you set a value manually, **Scale Coupling** automatically changes to **Off**.
- **Ref Position** - Allows you to set the reference position to either **Top**, **Ctr** (center) or **Bot** (bottom). The default setting is **Ctr**.

- **Scale Coupling** - Allows you to toggle the scale coupling function between **On** and **Off**. The default setting is **On**. Upon pressing the **Restart** front panel key or the **Restart** softkey under the **Meas Control** menu, this function automatically determines the scale per division and reference values based on the measurement results. When you set a value to either **Scale/Div** or **Ref Value** manually, **Scale Coupling** automatically changes to **Off**.

NOTE

The following additional keys become active for **Power Timing & Phase** view when the Phase window is active.

- **AMPLITUDE Y Scale**

- **Scale/Div** - Allows you to set the vertical scale by changing the value per division. The range is 0.0100 to 3600.0 degrees. The default setting is 5.00 degrees. However, since **Scale Coupling** default is **On**, this value is automatically determined by the measurement result. When you set a value manually, **Scale Coupling** automatically changes to **Off**.
- **Ref Value** - Allows you to set the reference value ranging from – 36000.0 to 36000.0 degrees. The default setting is 0.00 degrees. However, since **Scale Coupling** default is **On**, this value is automatically determined by the measurement results. When you set a value manually, **Scale Coupling** automatically changes to **Off**.
- **Ref Position** - Allows you to set the reference position to either **Top**, **Ctr** (center) or **Bot** (bottom). The default setting is **Ctr**.
- **Scale Coupling** - Allows you to toggle the scale coupling function between **On** and **Off**. The default setting is **On**. Upon pressing the **Restart** front panel key or the **Restart** softkey under the **Meas Control** menu, this function automatically determines the scale per division and reference values based on the measurement results. When you set a value to either **Scale/Div** or **Ref Value** manually, **Scale Coupling** automatically changes to **Off**.

Marker Key Menu

Key Path: **Marker**

- **Select** - Allows you to activate up to four markers with the corresponding numbers, respectively. The selected number is underlined and its function is defined by pressing the **Function** key. The default setting is 1.
- **Normal** - Allows you to activate the selected marker to read the power level and symbol code with the code layer. The marker position is controlled either by manual adjustment of the RPG knob or by direct entry of the Walsh code number via the front panel keypad.

- **Delta** - Allows you to read the differences in the power levels and symbols codes between the selected marker and the next.
- **Function** - Allows you to set the selected marker function to **Band Power**, **Noise**, or **Off**. The default setting is **Off**. The **Band Power** and **Noise** functions are not available for this measurement.
- **Trace** - Allows you to place the selected marker on the **Power**, **Timing**, or **Phase** trace. The default setting is **Power**.
- **Off** - Allows you to turn off the selected marker.
- **Shape** - Allows you to access the menu to set the selected marker shape to **Diamond**, **Line**, **Square**, or **Cross**. The default setting is **Diamond**.
- **Marker All Off** - Allows you to turn off all of the markers.

The front panel **Search** key performs a peak search when pressed. A marker will automatically be activated at the highest peak.

Modulation Accuracy (Rho) Keys

NOTE

Make sure the Mod Accuracy (Rho) measurement is selected under the **MEASURE** menu.

Meas Setup Key Menu

Key Path: **Meas Setup**

- **Avg Mode** - Allows you to choose either exponential or repeat averaging. This selection only effects the averaging after the number of N averages is reached (set using **Avg Number**).
 - **Normal averaging**: Normal (linear) averaging is always used until the specified number of N averages is reached. When **Measure** is set to **Single**, data acquisitions are stopped when the number of averages is reached - thus **Avg Mode** has no effect on single measurements.
 - **Exponential averaging**: When **Measure** is set at **Cont**, data acquisitions will continue indefinitely. After N averages, exponential averaging is used with a weighting factor of N (the displayed average count stops at N). Exponential averaging weights new data more than old data, which allows tracking of slow-changing signals. The weighting factor N is set using **Avg Number**.
 - **Repeat averaging**: When **Measure** is set at **Cont**, data acquisitions will continue indefinitely. After N averages is reached, all previous result data is cleared and the average count is set back to 1. This is equivalent to being in **Single** for **Measure** and pressing **Restart** each time the single measurement finishes.

Key Reference
cdmaOne Measurement Keys

- **Meas Interval** - Sets the time interval over which the measurement is made.
- **Spectrum** - This key, when set to **Invert**, conjugates the spectrum, which equivalently negates the quadrature component in demodulation. The correct setting (**Normal** or **Invert**) depends on whether the signal being input to the instrument has a high or low side mix.
- **Demod** - Defines the demodulation method such as synchronization signal, PN offset, and RF carrier selection.
 - **Sync Type** - Selects the type of synchronization used for the demodulation.
 - Even Sec (Rear Trig In)** - Synchronizes to the internal frame timer that has been synchronized to an even second clock input. The frame timer has a 26.6667 ms period. This input signal is connected to the rear panel TRIGGER IN connector.
 - Pilot Seq** - Synchronizes to the pilot sequence on the RF channel. As this does not provide an absolute time reference, the measured time offset value will not be valid.
 - Ext Front (Front Trig In)** - Directly synchronizes to an external signal connected to the front panel EXT TRIGGER INPUT connector.
 - Ext Rear (Rear Trig In)** - Directly synchronizes to an external signal connected to the rear panel TRIGGER IN connector.
 - None** - No synchronization is made.
 - **PN Offset** - Used to enter the PN offset of the base station being tested. This allows correct time offset values to be determined. This setting is not applicable when **Sync Type** is set to **Pilot Seq**.
 - **RF Carrier** - Select **Single** if there is a single RF carrier present at the RF input signal. Select **Multi** if there is more than one carrier present at the RF input signal, which rejects the upper and lower adjacent channels for the modulation accuracy and code domain measurements.
- **Restore Meas Defaults** - Press Meas Setup, More, Restore Meas Defaults to preset only the settings that are specific to the selected measurement. This will set the measure setup parameters, for the currently selected measurement only, to the factory defaults.

Table 3-4

Modulation Accuracy (Rho) Measurement Defaults

Measurement Parameter	Factory Default Condition
View/Trace	I/Q Measured Compl Vector
Display	
I/Q Points	750
Points/Chip	4
Chip Dots	On
Avg Frames	10; On
Avg Mode	Repeat
Meas Intvl	1.250 ms
Spectrum	Normal
Demod	
Sync Type	Even Sec (Rear Trig In)
PN Offset	0 × 64[chip]
RF Carrier	Single

View/Trace Key Menu

Key Path: **View/Trace**

- **I/Q Measured** - Provides a combination view of numeric results and a polar graph.

Pressing the **I/Q Measured** key reveals the menu for you to select one of the four different graphic views as follows:

- **Compl Vector** - Sets to view the I/Q complementary vector graph of the I/Q signals before the IS-95 complementary filter.
- **Compl ConstIn** - Sets to view the I/Q complementary constellation graph of the I/Q signals before the IS-95 complementary filter.
- **Polar Vector** - Sets to view the I/Q polar vector graph of the I/Q signals after the IS-95 complementary filter.
- **Polar ConstIn** - Sets to view the I/Q polar constellation graph of the I/Q signals after the IS-95 complementary filter.
- **I/Q Error (Quad-View)** - Provides a combination view of the Mag Error, Phase Error, and EVM graphs versus chips in the graph window and the numeric measurement results for Rho, Time Offset, Freq Error and so forth in the text window.

Figure 3-5 Modulation Accuracy Result - I/Q Error View (chip dots on)

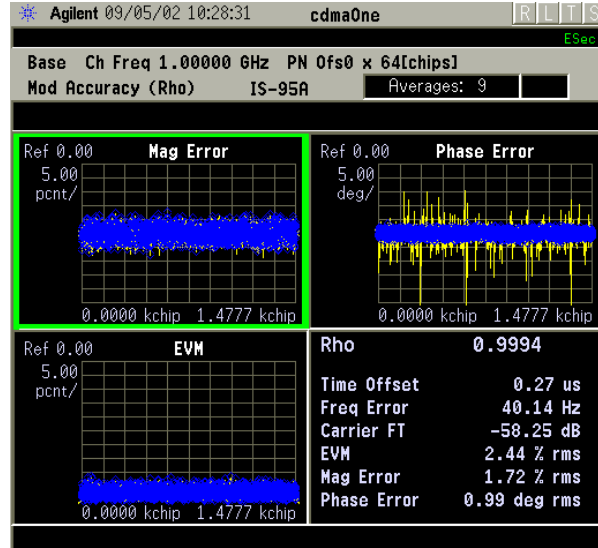

Any of these windows can be selected using the **Next Window** key and made full size using the **Zoom** key.

Display Key Menu

Key Path: **Display**

- **I/Q Points** - Allows you to specify the number of displayed points for the I/Q waveforms. The range is 1 to 5000 points. The default setting is 750.
- **Points/Chip** - Allows you to set the number of sample points displayed per chip to either 2, 4, or 8. The default selection is 4.
- **Chip Dots** - Allows you to switch the chip dot display between **On** and **Off**. The default setting is **On**. Set to **Off** if you do not want the chip dots to be superimposed on the result traces.

NOTE

The following additional keys become active for **I/Q Error (Quad-View)** view when either the EVM, Phase Error, or Mag Error window is active.

- **SPAN X Scale**
 - **Scale/Div** - Allows you to set the horizontal scale by changing a chip value per division. The range is 1.000 to 500000.0 chips per division with 0.001 chip resolution. The default setting is 147.8 chips per division. However, since the **Scale Coupling** default **On**, this value is automatically determined by the measurement result. When you set a value manually, **Scale Coupling** automatically changes to **Off**.
 - **Ref Value** - Allows you to set the chip reference value ranging from 0.000 to 5000000.0 chips. The default setting is 0.000 chip.

However, since the **Scale Coupling** default is **On**, this value is automatically determined by the measurement results. When you set a value manually, **Scale Coupling** automatically changes to **Off**.

- **Ref Position** - Allows you to set the reference position to either **Left**, **Ctr** (center) or **Right**. The default setting is **Left**.
- **Scale Coupling** - Allows you to toggle the scale coupling function between **On** and **Off**. The default setting is **On**. Upon pressing the **Restart** front panel key or the **Restart** softkey under the **Meas Control** menu, scale coupling automatically determines the scale per division and reference values based on the measurement results. When you set a value to either **Scale/Div** or **Ref Value** manually, **Scale Coupling** automatically changes to **Off**.

NOTE

The following additional keys become active for **I/Q Error (Quad-View)** view when either the **EVM** or **Mag Error** window is active.

- **AMPLITUDE Y Scale**

- **Scale/Div** - Allows you to set the vertical scale by changing the value per division. The range is 0.100 to 50.0% per division. The default setting is 5.00%. However, since the **Scale Coupling** default is **On**, this value is automatically determined by the measurement result. When you set a value manually, **Scale Coupling** automatically changes to **Off**.
- **Ref Value** - Allows you to set the reference value ranging from 0.00 to 500.0%. The default setting is 0.00%. However, since the **Scale Coupling** default is **On**, this value is automatically determined by the measurement results. When you set a value manually, **Scale Coupling** automatically changes to **Off**.
- **Ref Position** - Allows you to set the reference position to either **Top**, **Ctr** (center) or **Bot** (bottom). For the **EVM** graph, the default setting is **Bot**. For the **Mag Error** graph, the default setting is **Ctr**.
- **Scale Coupling** - Allows you to toggle the scale coupling function between **On** and **Off**. The default setting is **On**. Upon pressing the **Restart** front panel key or the **Restart** softkey under the **Meas Control** menu, scale coupling automatically determines the scale per division and reference values based on the measurement results. When you set a value to either **Scale/Div** or **Ref Value** manually, **Scale Coupling** automatically changes to **Off**.

NOTE

The following additional keys become active for **I/Q Error (Quad-View)** view when the **Phase Error** window is active.

- **AMPLITUDE Y Scale**

- **Scale/Div** - Allows you to set the vertical scale by changing the value per division. The range is 0.01 to 3600.0 degrees. The

Key Reference

cdmaOne Measurement Keys

default setting is 5.00 degrees per division. However, since the **Scale Coupling** default is **On**, this value is automatically determined by the measurement result. When you set a value manually, **Scale Coupling** automatically changes to **Off**.

- **Ref Value** - Allows you to set the reference value ranging from – 36000 to 36000 degrees. The default setting is 0.00 degrees. However, since the **Scale Coupling** default is **On**, this value is automatically determined by the measurement results. When you set a value manually, **Scale Coupling** automatically changes to **Off**.
- **Ref Position** - Allows you to set the reference position to either **Top**, **Ctr** (center) or **Bot** (bottom). The default setting is **Ctr**.
- **Scale Coupling** - Allows you to toggle the scale coupling function between **On** and **Off**. The default setting is **On**. Upon pressing the **Restart** front panel key or the **Restart** softkey under the **Meas Control** menu, scale coupling automatically determines the scale per division and reference values based on the measurement results. When you set a value to either **Scale/Div** or **Ref Value** manually, **Scale Coupling** automatically changes to **Off**.

Marker Key Menu

Key Path: **Marker**

- **Select** - Allows you to activate up to four markers with the corresponding numbers, respectively. The selected number is underlined and its function is defined by pressing the **Function** key. The default setting is 1.
- **Normal** - Allows you to activate the selected marker to read the magnitude or phase error and the number of chips of the marker position on the selected trace, for example. Marker position is controlled by the RPG knob.
- **Delta** - Allows you to read the differences in the magnitude or phase errors and the number of chips between the selected marker and the next.
- **Function** - Allows you to set the selected marker function to **Band Power**, **Noise**, or **Off**. The default setting is **Off**. The **Band Power** and **Noise** functions are not available for this measurement.
- **Trace** - Allows you to place the selected marker on the **EVM**, **Phase Error**, or **Mag Error** trace. The default setting is **EVM**.
- **Off** - Allows you to turn off the selected marker.
- **Shape** - Allows you to access the menu to set the selected marker shape to **Diamond**, **Line**, **Square**, or **Cross**. The default setting is **Diamond**.
- **Marker All Off** - Allows you to turn off all of the markers.

Spectrum (Frequency Domain) Keys

NOTE You must have selected **Spectrum** under the **MEASURE** menu to access these menus

Meas Setup Key Menu

Key Path: **Meas Setup**

- **Span** - Modifies the frequency span. The range is 10 Hz to 10 MHz with 1 Hz resolution, depending on the **Res BW** setting. Changing the span causes the resolution bandwidth to change automatically, and will affect data acquisition time. For PSA Option 122 wideband operation, the maximum span is 80 MHz. For PSA Option 140 wideband operation, the maximum span is 40 MHz.
- **Res BW** - Sets the resolution bandwidth for the FFT, and to toggle its mode between **Auto** and **Man** (manual). If set to **Auto**, the resolution bandwidth is set to **Span/50** (2% of the span). If set to **Man**, you can enter a value ranging from 100.0 mHz to 3.00000 MHz. A narrower bandwidth will result in a longer data acquisition time.
- **Wideband Setup** (PSA Options 122 and 140 only.) configures the wideband hardware path.
 - **Wideband IF Gain** - Sets the gain for the wideband IF path in 2 dB steps from - 12 to +12 dB. You must have selected **IF Path Wide**. Increasing the gain can increase the amplitude of small signals as long as you don't overdrive the hardware. Wideband gain should usually be adjusted after setting the input attenuation.
 - **Wideband Filtering** - Accesses the keys to configure the optional channel filter. The default is no filtering.
 - Filter Type** - Selects **None** for no filtering, or **Raised Cosine**, **RRC** (root-raised cosine), **Nyquist**, **Root Nyquist**, and **Gaussian**.
 - Filter Alpha** - Selects the filter alpha.
 - Filter BW** - Selects filter bandwidth. Bandwidth is not entered as a frequency. The value is entered as a ratio of the current instrument sampling rate (i.e. BW/sample rate).
 - **Wideband Advanced** - These keys are only for the PSA Option 122 or 140 in wideband operation. Accesses the advanced settings for the wideband IF hardware path.

NOTE Parameters under the **Wideband Advanced** key seldom need to be changed. Any changes from the default advanced values may result in invalid measurement data.

Key Reference
cdmaOne Measurement Keys

- ❑ **ADC Corr** Turning corrections on performs an ADC calibration to reduce the spectral image and applies the corrections.
- ❑ **IF Flat Corr** turns IF flatness corrections on and off for the Option 122 or 140 wideband IF. This control is independent of the narrowband IF flatness control.
- ❑ **Analog Filter** manually selects the 80 MHz (Option 122), 40 MHz (Option 140), or 36 MHz anti-alias filter, which overrides the automatic selection of the bandwidth.
- ❑ **WB ADC Dither** Toggles the ADC dither function on/off.. The “ADC dither” refers to the introduction of noise to the digitized steps of the analog-to-digital converter; the result is an improvement in amplitude accuracy. The wideband dither control does not affect the ADC dither in the narrowband IF path.
- ❑ **FFT Window** - Accesses the following selection menu. Unless you are familiar with FFT windows, use the flat top filter (the default filter).
 - ❑ **Flat Top** - Selects this filter for best amplitude accuracy by reducing scalloping error.
 - ❑ **Uniform** - Select this filter to have no window active by using the uniform setting.
 - ❑ **Hanning** - Press this key to activate the Hanning filter.
 - ❑ **Hamming** - Press this key to activate the Hamming filter.
 - ❑ **Gaussian** - Press this key to activate the Gaussian filter with the roll-off factor (alpha) of 3.5.
 - ❑ **Blackman** - Press this key to activate the Blackman filter.
 - ❑ **Blackman Harris** - Press this key to activate the Blackman Harris filter.
 - ❑ **K-B 70dB/90dB/110dB (Kaiser-Bessel)** - Select one of the Kaiser-Bessel filters with sidelobes at – 70, – 90, or – 110 dBc.
- ❑ **FFT Size** - Accesses the menu to change the following parameters:
 - ❑ **Length Ctrl** - Toggles the FFT and window length setting function between **Auto** and **Man** (manual).
 - ❑ **Min Pts in RBW** - Sets the minimum number of data points that will be used inside the resolution bandwidth. The range is 0.10 to 100.00 points with 0.01 resolution. This key is grayed out if **Length Ctrl** is set to **Man**.

- ❑ **Window Length** - Enters the FFT window length in the number of capture samples, ranging from 8 to 1048576. This length represents the actual quantity of I/Q samples that are captured for processing by the FFT (“Capture Time” is the associated parameter shown on the screen). This key is grayed out if **Length Control** is set to **Auto**.
 - ❑ **FFT Length** - Enters the FFT length in the number of captured samples, ranging from 8 to 1048576. The FFT length setting is automatically limited so that it is equal to or greater than the FFT window length setting. Any amount greater than the window length is implemented by zero-padding. This key is grayed out if **Length Control** is set to **Auto**.
 - **Average**
 - **Avg Number** - Changes the number of N averages.
 - **Avg Mode** - Toggles the averaging mode between **Exp** (exponential) and **Repeat**. This selection only effects on the averaging result after the number of N averages is reached. The N is set using the **Avg Number** key.
 - **Normal averaging:** Normal (linear) averaging is always used until the specified number of N averages is reached. When the **Measure** key under **Meas Control** is set to **Single**, data acquisition is stopped when the number of N averages is reached, thus **Avg Mode** has no effect in the single measurement mode.
 - **Exponential averaging:** When **Measure** is set to **Cont**, data acquisition will continue indefinitely. Exponential averaging is used with a weighting factor of N (the displayed count of averages stops at N). Exponential averaging weights new data more heavily than old data, which allows tracking of slow-changing signals. The weighting factor N is set using the **Avg Number** key.
 - **Repeat averaging:** When **Measure** is set to **Cont**, data acquisition will continue indefinitely. After the number of N averages is reached, all previous result data is cleared and the average count displayed is set back to 1. This is equivalent to being in **Measure Single** and pressing the **Restart** key each time the single measurement finishes.
 - **Avg Type** - Accesses the menu of the following average types only for making spectrum (frequency domain) and waveform (time domain) measurements:
 - ❑ **Pwr Avg (RMS)** - Executes the true power averaging which is calculated by averaging the rms voltage. This is the most accurate type.

Key Reference
cdmaOne Measurement Keys

- ❑ **Log-Pwr Avg (Video)** - Simulates the traditional spectrum analyzer type of averaging by calculating the log of the power. This type of averaging will underestimate the power when the signal is noise-like.
 - ❑ **Voltage Avg** - Executes voltage averaging.
 - ❑ **Maximum** - Captures peak voltage data. Simulates the traditional spectrum analyzer peak hold function.
 - ❑ **Minimum** - Captures the minimum voltage data, similar to the maximum function.
- **Time Avg Num** - Changes the number of time averages to be made when using the Option 122 or 140 wideband hardware (PSA only). This averaging requires a frame trigger and is much faster than the standard averaging. This hardware averaging is done on the complex voltage time trace data before any measurement application averaging is done. Both types of averaging can be done on the same measurement data.

When time averaging is being done, each trace update represents N fresh data acquisitions averaged together, where N is the number of averages. You cannot access the individual time records that are being averaged in the hardware averager.

NOTE If your triggering is not set correctly, the signal can be averaged away to nothing. A **HW Average** message is displayed to show that the averaging is on.

- **Trig Source**

Key path: **Meas Setup, Trig Source**

NOTE Changing the selection in the **Trig Source** menu alters the trigger source for the selected measurement only.

- **Free Run (Immediate)** - A trigger occurs at the time the data is requested, completely asynchronous with the RF or IF signal.
- **Video (Envlp)** - An internal IF envelope trigger that occurs at the absolute threshold level of the IF signal level.
- **RF Burst (Wideband)** - An internal wideband RF burst trigger that has the automatic level control for burst signals. It triggers at the level that is set relative to the peak RF signal (12 MHz bandwidth) input level. (Not available for Option 122 or 140 when using the wideband IF path.)
- **Ext Front** - Activates the front panel external trigger input (**EXT TRIGGER INPUT**) port. The external signal must be between -5.00 and $+5.00$ V with 1 or 10 mV resolution.

- **Ext Rear** - Activates the rear-panel external trigger input (**TRIGGER IN**) port. The external signal must be between -5.00 and $+5.00$ V with 1 or 10 mV resolution.
- **Frame** - Uses the internal frame clock to generate a trigger signal. The clock parameters are controlled under the **Mode Setup** key or the measurement firmware, but not both. Refer to the specific measurement section for details.
- **Line** - Sets the trigger to the internal line mode. Sweep triggers occur at intervals synchronous to the line frequency. See the specific measurement section for details.
- **IF Path** Only for PSA with Option B7J and either Option 122 or 140 installed. Selects either the standard narrowband IF hardware path or the wideband hardware.
- **Restore Meas Defaults** - Presets only the settings that are specific to the selected measurement by pressing **Meas Setup, More (1 of 2), Restore Meas Defaults**. This will set the measure setup parameters, for the currently selected measurement only, to the factory defaults.
- **(Narrowband) Advanced** Accesses the menu to change the following parameters.

NOTE

The advanced features should be used only if you are familiar with their operation. Changes from the default values may result in invalid data.

The **Narrowband** key word is only present if you have Option B7J and either Option 122 or 140 installed. Parameters that are under the **(Narrowband) Advanced** key only affect the standard narrow band IF path. The wideband IF advanced functions are found under the **Wideband Advanced** key.

- **Pre-ADC BPF** - Toggles the pre-ADC bandpass filter function between **On** and **Off**. The pre-ADC bandpass filter is useful for rejecting nearby signals, so that sensitivity within the span range can be improved by increasing the ADC range gain.
- **Pre-FFT Filtr** - Toggles the pre-FFT filter between **Flat** (flat top) and **Gaussian**. The pre-FFT filter defaults to a flat top filter which has better amplitude accuracy. The Gaussian filter has better pulse response.
- **Pre-FFT BW** - Toggles the pre-FFT bandwidth function between **Auto** and **Man** (manual). The pre-FFT bandwidth filter can be set between 1 Hz and 10 MHz. If set to **Auto**, this pre-FFT bandwidth is nominally 50% wider than the span. This bandwidth determines the ADC sampling rate.
- **FFT Window** - Accesses the following selection menu. Unless you are familiar with FFT windows, use the flat top filter (the default filter).

- Flat Top** - Selects this filter for best amplitude accuracy by reducing scalloping error.
 - Uniform** - Select this filter to have no window active by using the uniform setting.
 - Hanning** - Press this key to activate the Hanning filter.
 - Hamming** - Press this key to activate the Hamming filter.
 - Gaussian** - Press this key to activate the Gaussian filter with the roll-off factor (alpha) of 3.5.
 - Blackman** - Press this key to activate the Blackman filter.
 - Blackman Harris** - Press this key to activate the Blackman Harris filter.
 - K-B 70dB/90dB/110dB (Kaiser-Bessel)** - Select one of the Kaiser-Bessel filters with sidelobes at -70 , -90 , or -110 dBc.
- **FFT Size** - Accesses the menu to change the following parameters:
- Length Ctrl** - Toggles the FFT and window length setting function between **Auto** and **Man** (manual).
 - Min Pts in RBW** - Sets the minimum number of data points that will be used inside the resolution bandwidth. The range is 0.10 to 100.00 points with 0.01 resolution. This key is grayed out if **Length Ctrl** is set to **Man**.
 - Window Length** - Enters the FFT window length in the number of capture samples, ranging from 8 to 1048576. This length represents the actual quantity of I/Q samples that are captured for processing by the FFT (“Capture Time” is the associated parameter shown on the screen). This key is grayed out if **Length Control** is set to **Auto**.
 - FFT Length** - Enters the FFT length in the number of captured samples, ranging from 8 to 1048576. The FFT length setting is automatically limited so that it is equal to or greater than the FFT window length setting. Any amount greater than the window length is implemented by zero-padding. This key is grayed out if **Length Control** is set to **Auto**.
- **ADC Range** - Accesses the menu to define one of the following ADC ranging functions:
- Auto** - Sets the ADC range automatically. For most FFT spectrum measurements, the auto feature should not be selected. An exception is when measuring a signal which is “bursty”, in which case auto can maximize the time domain dynamic range, if FFT results are less important to you than time domain results.

- Auto Peak** - Sets the ADC range automatically to the peak signal level. Auto peak is a compromise that works well for both CW and burst signals.
 - Auto Peak Lock** - Select this to hold the ADC range automatically at the peak signal level. Auto peak lock is more stable than auto peak for CW signals, but should not be used for “bursty” signals.
 - Manual** - Accesses the selection menu of values, -6 to +24 dB for E4406A or None to +18 dB for PSA, to set the ADC range level. Also note that manual ranging is best for CW signals.
- **Data Packing** - Selects **Auto** (the default) or the **Short (16 bit)**, **Medium (24 bit)** and **Long (32 bit)** methods of data packing. The short, medium, and long methods are not compatible with all settings and should not be used unless you are familiar with data packing methods. **Auto** is the preferred choice.
- Auto** - The data packing value most appropriate for current instrument settings is selected automatically.
 - Short (16 bit)** - Select this to pack data every 16 bits.
 - Medium (24 bit)** - Select this to pack data every 24 bits.
 - Long (32 bit)** - Select this to pack data every 32 bits.
- **ADC Dither** - Toggles the ADC dither function between **Auto**, **On**, and **Off**. When set to **Auto** (the default), the ADC dither function will be activated when a narrow bandwidth is being measured, and deactivated when a wide bandwidth is being measured. “ADC dither” refers to the introduction of noise to the digitized steps of the analog-to-digital converter; the result is an improvement in amplitude accuracy. Use of the ADC dither, however, reduces dynamic range by approximately 3 dB.
- **Decimation** - Toggles the decimation function between **Auto** and **Man**, and to set the decimation value. **Auto** is the preferred setting, and the only setting that guarantees alias-free FFT spectrum measurements. If you are familiar with the decimation feature, you can change the decimation value by setting to **Man**, but be aware that aliasing can result in higher values. Decimation numbers 1 to 1000 describe the factor by which the number of points are reduced. The default setting is 0, which results in no data point reduction. Decimation by 3 keeps every 3rd sample, throwing away the 2 in between.
- **IF Flatness** - Toggles the IF flatness function between **On** and **Off**. If set to **On** (the default), the IF flatness feature causes background amplitude corrections to be performed on the FFT spectrum. The **Off** setting is used for adjustment and troubleshooting of the test instrument.

The following table shows the factory default settings for spectrum (frequency domain) measurements.

Table 3-5 Spectrum (Frequency Domain) Measurement Defaults

Measurement Parameter	Factory Default Condition
Trace Display	All
Res BW	20.0000 kHz; Auto
Averaging:	
Avg Number	25; On
Avg Mode	Exp
Avg Type	Log-Pwr Avg (Video)
Time Avg Num (Opt. 122 or 140)	1
Trig Source	Free Run (Immediate)
Region/Limits:	
Region	A
Upper Mask	A: - 40.00 dB; On
Lower Mask	A: - 100.00 dB; Off
Offset Start	A: - 667.0 μ s
Offset Stop	A: - 25.0 μ s
Interval	A: 642.0 μ s
IF Path (requires Option B7J and Option 122 or 140)	Narrow
Wideband IF Gain (Opt. 122 or 140)	0.00 dB
Wideband Filtering (Opt. 122 or 140)	None
Filter Type	0.30
Filter Alpha	0.50
Filter BW	
Spectrum View:	
SPAN	1.000 MHz (VSA), 10.000 MHz (PSA)
AMPLITUDE Y Scale - Scale/Div	10.00 dB
I/Q Waveform View:	
Capture Time	188.00 μ s
AMPLITUDE Y Scale - Scale/Div	100.0 mV
Spectrum Linear View:	(for E4406A)
SPAN	1.00000 MHz
AMPLITUDE Y Scale - Scale/Div	100.0 mV
I and Q Waveform View:	(for E4406A)
Capture Time	188.00 μ s
AMPLITUDE Y Scale - Scale/Div	100.0 mV

Table 3-5 Spectrum (Frequency Domain) Measurement Defaults

Measurement Parameter	Factory Default Condition
I/Q Polar View: I/Q Scale/Div I or Q Origin	(for E4406A) 100.0 mV 0.00 V
(Narrowband) Advanced	
Pre-ADC BPF	On
Pre-FFT Filter	Flat
Pre-FFT BW	1.55000 MHz; Auto
FFT Window	Flat Top (High Amptd Acc)
FFT Size:	
Length Control	Auto
Min Points/RBW	3.100000
Window Length	706 (VSA), 566 (PSA)
FFT Length	1024
ADC Range	Auto Peak
Data Packing	Auto
ADC Dither	Auto
Decimation	0; Auto
IF Flatness	On
Wideband Advanced (Option 122 or 140 PSA only)	
ADC Correction	On
IF Flatness Corrections	On
Analog Filter	Auto, 80 MHz (Opt 122), 40 MHz (Opt 140)
WB ADC Dither	On
FFT Window	Flat Top (High Amptd Acc)
FFT Size:	
Length Control	Auto
Min Points/RBW	3.100
Window Length	236 (Opt. 122), 118 (Opt. 140)
FFT Length	256 (Opt. 122), 128 (Opt. 140)

View/Trace Key Menu

The View/Trace key allows you to select the desired view of the measurement from the following. You can use the Next Window key to move between the multiple windows (if any) and make it full size by Zoom.

- **Spectrum** - Provides a combination view of the spectrum graph in parameters of power versus frequency with semi-log graticules, and the I/Q waveform graph in parameters of voltage and time. Changes to frequency span or power will sometimes affect data acquisition. This is equivalent to changing the selected window with the **Next** key.

Figure 3-6 Spectrum Measurement - Spectrum and I/Q Waveform (Default View)

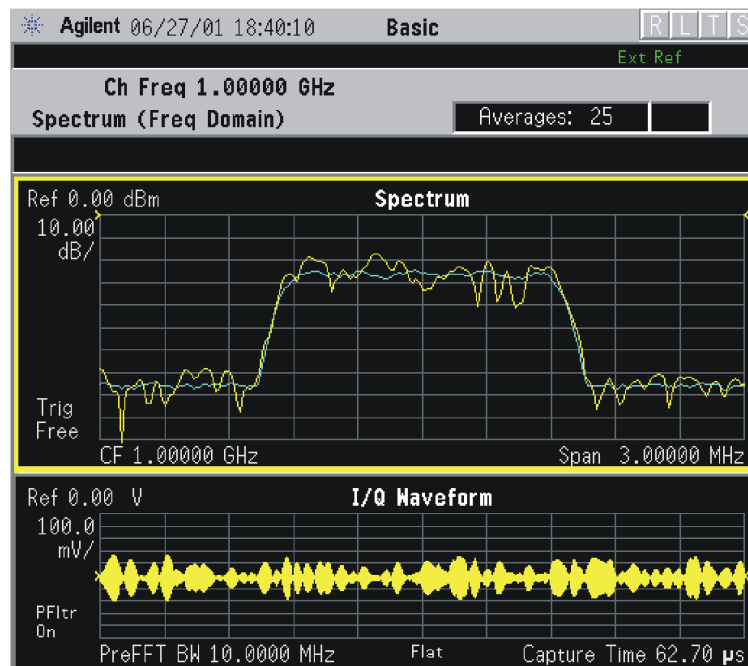
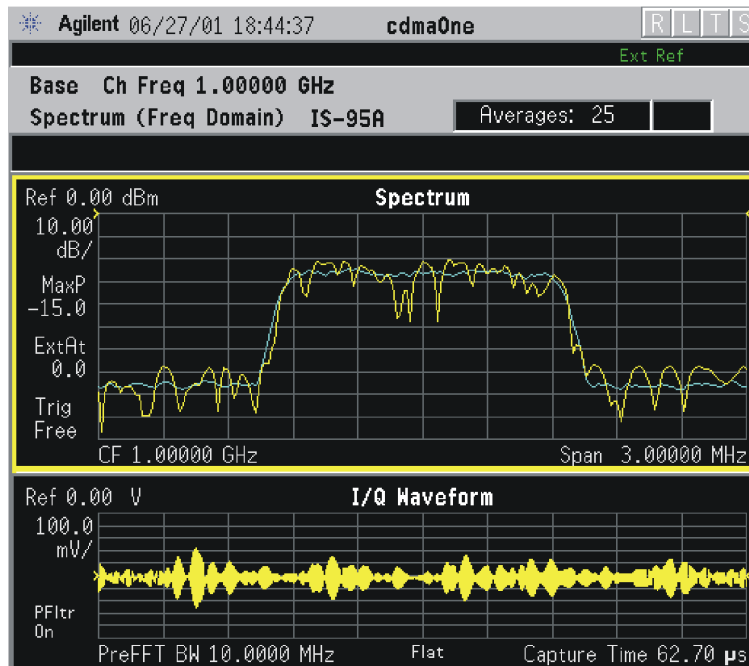

Figure 3-7 Spectrum Measurement - Spectrum and I/Q Waveform (Default) View



The spectrum measurement result should look like the above figure. The measurement result values are shown in the summary result window.

- **Spectrum (Time Domain) I/Q Waveform** - (Key for PSA only) This graph is shown below the **Spectrum** graph in the default dual-window display. **I/Q Waveform** provides a view of the I/Q waveform in parameters of voltage versus time in linear scale. Changes to sweep time or resolution bandwidth can affect data acquisition. Pressing this button is equivalent to pressing the **Next Window** button on the front panel. Press the **Zoom** key to view this display full-screen.

Key Reference
cdmaOne Measurement Keys

- **Spectrum Linear** - (for E4406A) Provides a view of the spectrum graph in parameters of voltage versus frequency in linear scale. Changes to frequency span or voltage can affect data acquisition.

Figure 3-8 Spectrum Measurement - Linear Spectrum View (for E4406A)

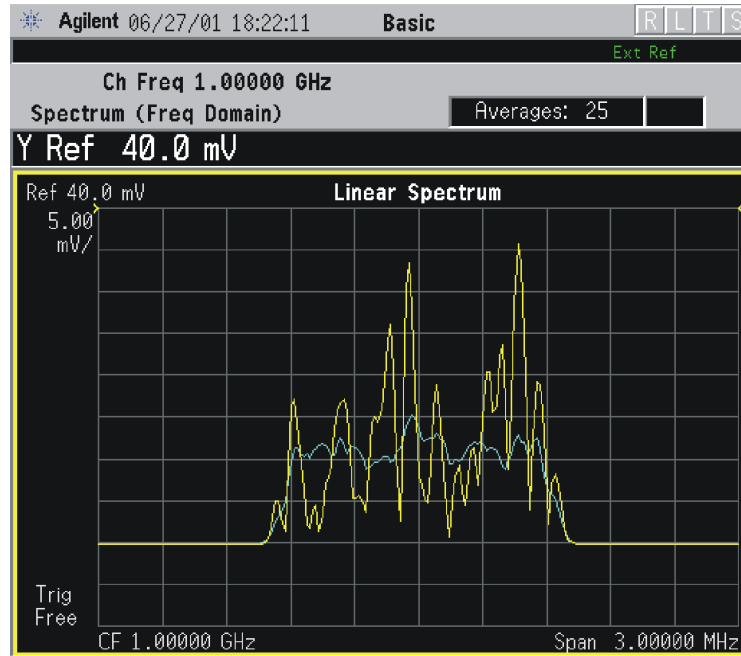

*Meas Setup: View/Trace = Spectrum Linear,
Span = 3.000 MHz,
Y Scale/Div = 5.00 mV, Ref Value = 30.0 mV,
Others = Factory default settings

*Input signals: - 10.00 dBm, 9 channels of SR1, cdma2000 Rev 8

NOTE

(for E4406A) For the widest spans, the I/Q window becomes just “ADC time domain samples”, because the I/Q down-conversion is no longer in effect. This is not the case for E4406A Option B7C if the **Input Port** is set to either **I/Q**, **I only**, or **Q only** and you have connected baseband I/Q signals to the **I/Q INPUT** connectors.

- **I and Q Waveform** - (for E4406A) Provides individual views of the I and Q signal waveform windows in parameters of voltage versus time.

To select the I or Q trace view, press the **Next** key at the bottom of the display. The selected window will have a green outline. To view the window full size press the **Zoom** key.

Figure 3-9 Spectrum Measurement - I and Q Waveform View (for E4406A)

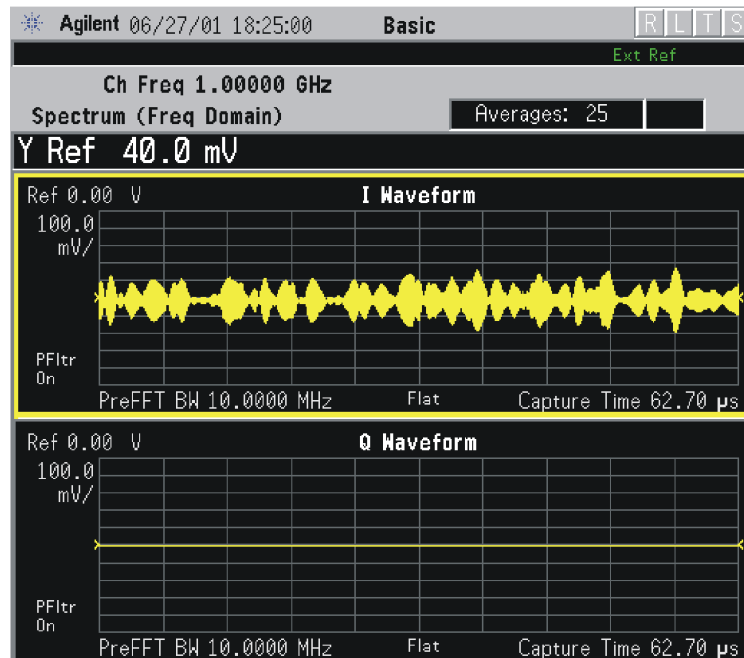
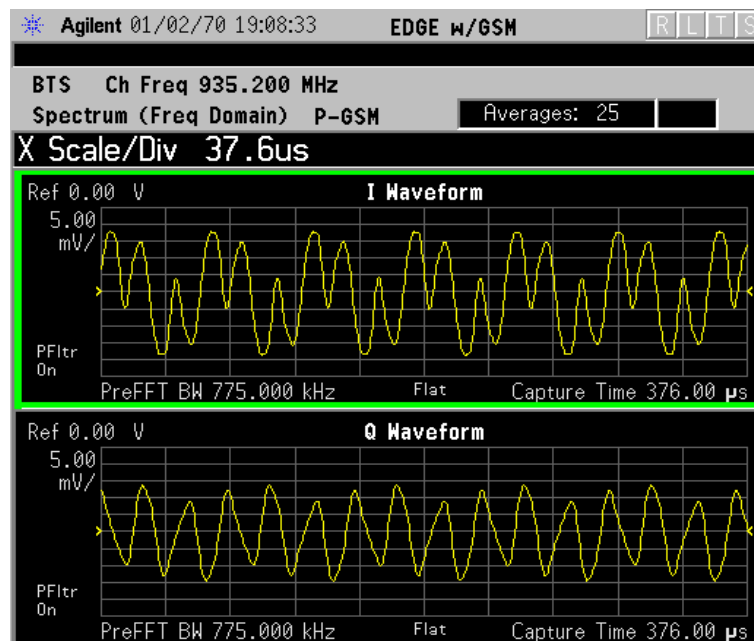
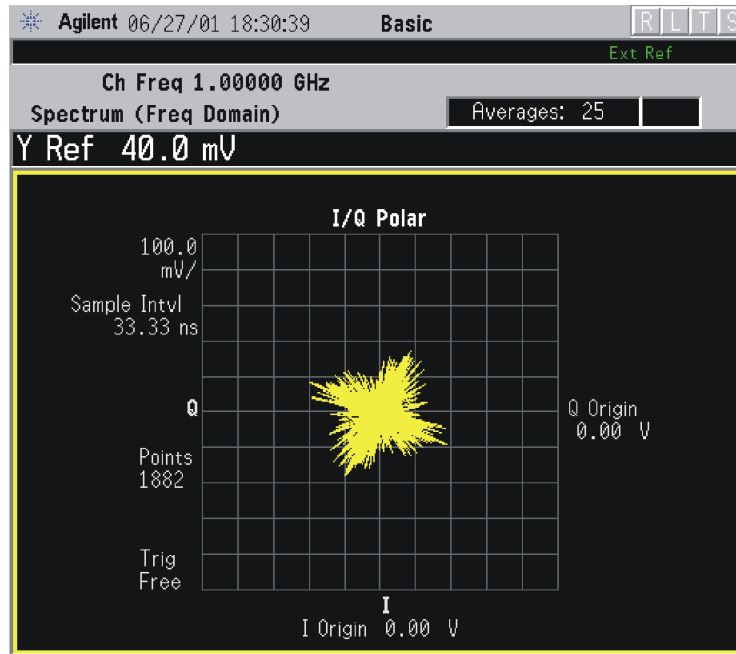

Figure 3-10 Spectrum Measurement - I and Q Waveform View (for E4406A)



- **I/Q Polar** - (for E4406A) Provides a view of the I/Q signal displayed in a polar vector graph.

Figure 3-11 Spectrum Measurement - I/Q Polar View (for E4406A)

*Meas Setup: View/Trace = I/Q Polar,
Others = Factory default settings

*Input signals: - 10.00 dBm, Pilot channel, 1xEV-DO

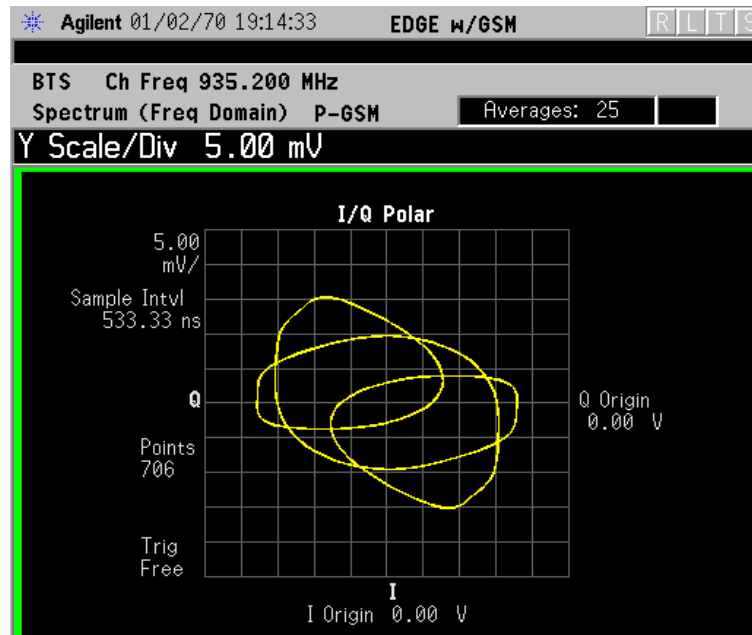
Figure 3-12 Spectrum Measurement - I/Q Polar View (for E4406A)

- **Trace Display** - Press this key to reveal the trace selection menu. The currently selected trace type is shown on the **Trace Display** key.
 - **All** - Views both the current trace and the average trace.
 - **Average** - Views only the average trace (in blue color). See the **Meas Setup, Average** keys to select different types of averaging.
 - **Current** - Views only the trace (in yellow color) for the latest data acquisition.
 - **I Trace** - (for E4406A) Views only the I signal trace.
 - **Q Trace** - (for E4406A) Views only the Q signal trace.

SPAN X Scale Key Menu

NOTE

The **Spectrum** or **Linear Spectrum** (for E4406A) window must be active in the **Spectrum** or **Spectrum Linear** (for E4406A) view to access the following **Span X Scale** key menu:

- **Span** - Modifies the frequency span. The range is 10.000 Hz to 10.000 MHz with 1 Hz resolution, depending on the **Res BW** setting. Changing the span causes the resolution bandwidth to change automatically, and will affect data acquisition time. The **Span** key is also accessible under the **Meas Setup** menu.
- **IF Path** - This key is only available if you have Option B7J and either Option 122 or 140. Selects either the standard narrowband IF hardware path or the wideband hardware path.

NOTE

The **I/Q Waveform** (for E4406A) window must be active in the **Spectrum** or **Spectrum Linear** (for E4406A) view to access the following **Span X Scale** key menu:

- **Scale/Div** - Sets the horizontal scale by changing a time value per division. The range is 1.00 ns to 1.00 s per division. The default setting is 18.8 ms per division. However, since the **Scale Coupling** default is **On**, this value is automatically determined by the measurement results. When you set a value manually, **Scale Coupling** automatically changes to **Off**.
- **Ref Value** - Sets the reference value ranging from – 1.00 to 10.0 s. The default setting is 0.00 s. However, since the **Scale Coupling** default is **On**, this value is automatically determined by the measurement results. When you set a value manually, **Scale Coupling** automatically changes to **Off**.
- **Ref Position** - Sets the reference position to either **Left, Ctr** (center) or **Right**. The default setting is **Left**.

- **Scale Coupling** - Toggles the scale coupling function between **On** and **Off**. The default setting is **On**. Upon pressing the **Restart** front-panel key or **Restart** softkey under the **Meas Control** menu, this function automatically determines the scale per division and reference values based on the measurement results. When you set a value to either **Scale/Div** or **Ref Value** manually, **Scale Coupling** automatically changes to **Off**.

NOTE

The I/Q Polar window must be active in the **I/Q Polar** view (for E4406A), for the **SPAN X Scale** key to access the following menu:

- **I/Q Scale/Div** - Sets the vertical and horizontal scales by changing the value per division. The range is 1.00 nV to 20.00 V per division. The default setting is 100.0 mV.
- **I Origin** or **Q Origin** - Sets the reference value ranging from -250.00 to 250.00 V. The default setting is 0.00 V.

AMPLITUDE Y Scale Key Menu**NOTE**

The Spectrum or Linear Spectrum (for E4406A) window must be active in the **Spectrum** or **Spectrum Linear** (for E4406A) view to access the following **AMPLITUDE Y Scale** key menu:

- **Scale/Div** - Sets the vertical scale by changing an amplitude value per division. The range is 0.10 dB to 20.00 dB per division or 1.00 nV to 20.00 V per division, respectively. The default setting is 10.00 dB or 100.0 mV. However, since the **Scale Coupling** default is **On**, this value is automatically determined by the measurement results. When you set a value manually, **Scale Coupling** automatically changes to **Off**.
- **Ref Value** - Sets the reference value ranging from -250.00 to 250.00 dBm or -250.00 to 250.00 V. The default setting is 0.00 dBm or 0.00 V. However, since the **Scale Coupling** default is **On**, this value is automatically determined by the measurement results. When you set a value manually, **Scale Coupling** automatically changes to **Off**.
- **Ref Position** - Sets the reference position to either **Top**, **Ctr** (center) or **Bot** (bottom). The default setting is **Ctr**.
- **Scale Coupling** - Toggles the scale coupling function between **On** and **Off**. The default setting is **On**. Upon pressing the **Restart** front-panel key or **Restart** softkey under the **Meas Control** menu, this function automatically determines the scale per division and reference values based on the measurement results. When you set a value to either **Scale/Div** or **Ref Value** manually, **Scale Coupling** automatically changes to **Off**.

NOTE

The I or Q Waveform window must be active in the **I and Q Waveform** view (**for E4406A**) for the **AMPLITUDE Y Scale** key to access the following menu:

- **Scale/Div** - Sets the vertical scale by changing the amplitude value per division. The range is 1.00 nV to 20.00 V per division. The default setting is 100.0 mV. However, since the **Scale Coupling** default is **On**, this value is automatically determined by the measurement results. When you set a value manually, **Scale Coupling** automatically changes to **Off**.
- **Ref Value** - Sets the reference value ranging from -250.00 to 250.00 V. The default setting is 0.00 V. However, since the **Scale Coupling** default is **On**, this value is automatically determined by the measurement results. When you set a value manually, **Scale Coupling** automatically changes to **Off**.
- **Ref Position** - Sets the reference position to either **Top**, **Ctr** (center) or **Bot** (bottom). The default setting is **Ctr**.
- **Scale Coupling** - Toggles the scale coupling function between **On** and **Off**. The default setting is **On**. The **Restart** front-panel key or **Restart** softkey under the **Meas Control** menu, this function automatically determines the scale per division and reference values by the measurement results. When you set a value to either **Scale/Div** or **Ref Value** manually, **Scale Coupling** automatically changes to **Off**.

NOTE

The I/Q Polar window must be active in the **I/Q Polar** view (for E4406A), for the **AMPLITUDE Y Scale** key to access the following menu:

- **I/Q Scale/Div** - Sets the vertical and horizontal scales by changing the value per division. The range is 1.00 nV to 20.00 V per division. The default setting is 100.0 mV.
- **I Origin** or **Q Origin** - Sets the reference value ranging from -250.00 to 250.00 V. The default setting is 0.00 V.

Display Key Menu

The Display Key is not active for this measurement.

Marker Key Menu

- **Select 1 2 3 4** - Activates up to four markers with the corresponding numbers, respectively. The selected number is underlined and its function is defined by pressing the **Function** key. The default is 1.
- **Normal** - Activates the selected marker to read the frequency and amplitude of the marker position on the spectrum trace. Marker position is controlled by the **RPG** knob.

Key Reference

cdmaOne Measurement Keys

- **Delta** - Reads the differences in frequency and amplitude between the selected marker and the next marker.
- **Function Off** - Selects marker function to be **Band Power**, **Noise**, or **Off**. The default is **Off**. If set to **Band Power**, you need to select **Delta**.
- **Trace Spectrum** - Places the selected marker on the **Spectrum**, **Spectrum Avg**, **Spectrum Linear** (for E4406A), **Spectrum Avg Linear** (for E4406A), **I/Q Waveform**, **I Waveform** (for E4406A), or **Q Waveform** (for E4406A) or **I/Q Waveform** trace. The default is **Spectrum**.
- **Off** - Turns off the selected marker.
- **Shape Diamond** - Accesses the menu to define the selected marker shape to be **Diamond**, **Line**, **Square**, or **Cross**. The default shape is **Diamond**.
- **Marker All Off** - Turns off all of the markers.

Peak Search Key

The front panel Search key performs a peak search when pressed. A marker will automatically be activated at the highest peak.

Spur Close Keys

NOTE

Make sure the Spur Close measurement is selected under the **MEASURE** menu.

Meas Setup Key Menu

Key Path: **Meas Setup**

- **Avg Number** - Allows you to change the number of N averages to be made.
- **Avg Mode** - Allows you to choose either exponential or repeat averaging. This selection only effects the averaging after the number of N averages is reached (set using **Avg Number**).
 - **Normal averaging:** Normal (linear) averaging is always used until the specified number of N averages is reached. When **Measure** is set to **Single**, data acquisitions are stopped when the number of averages is reached - thus **Avg Mode** has no effect on single measurements.
 - **Exponential averaging:** When **Measure** is set at **Cont**, data acquisitions will continue indefinitely. After N averages, exponential averaging is used with a weighting factor of N (the displayed average count stops at N). Exponential averaging weights new data more than old data, which allows tracking of slow-changing signals. The weighting factor N is set using **Avg Number**.

- **Repeat averaging:** When **Measure** is set at **Cont**, data acquisitions will continue indefinitely. After N averages is reached, all previous result data is cleared and the average count is set back to 1. This is equivalent to being in **Single** for **Measure** and pressing the **Restart** key each time the single measurement finishes.
- **Meas Type** - Allows you to toggle the measurement bandwidth between **Full** and **Examine**. If set to **Full**, all segments are measured and displayed. If set to **Examine** with the continuous measurement mode, each segment is repetitively measured and the segment where the worst spurious signal is found can be repetitively measured and displayed for further tests.
- **Tx Spur >4 MHz Limit** - Allows you to access the selection menu for the limit masks at the frequency offset more than 4 MHz.
 - **Category A** - Sets to use the limit level of power spectral density -13 dBm/100 kHz for Band Class 0 or 3, or -13 dBm/1 MHz for Band Class 1 or 4.
 - **Category B** - Sets to use the limit level of power spectral density -36 dBm/100 kHz for Band Class 0 or 3, or -30 dBm/1 MHz for Band Class 1 or 4.
 - **None** - Sets not to use the limit mask, and **Upper Segment** and **Lower Segment** are grayed out.
- **Restore Meas Defaults** - Press Meas Setup, More, Restore Meas Defaults to preset only the settings that are specific to the selected measurement. This will set the measure setup parameters, for the currently selected measurement only, to the factory defaults.

Table 3-6

Spur Close Measurement Defaults

Measurement Parameter	Factory Default Condition
View/Trace	Center Segment
Avg Number	15; On
Avg Mode	Repeat
Meas Type	Full
Tx Spur >4 MHz Limit	Category A

View/Trace Key Menu

Key Path: **View/Trace**

The **View/Trace** key will allow you to select the desired view of the measurement from the following. Each of these choices selects a different part of the frequency spectrum for viewing. The Center Segment shows the spectrum centered on the carrier channel frequency.

Key Reference
cdmaOne Measurement Keys

When **Radio Std** is set to **IS-95A**, or when **Radio Std** is set to **IS-97D IS-98D** and **Band Class** is set to **0 (800 MHz)** or **3 (JTACS)** for **Base** and **Mobile** tests, or when **Band Class** is set to **1 (1900 MHz)** or **4 (Korean PCS)** for **Mobile** tests, there are three measurement segments to be selected as follows:

- Lower Segment
- Center Segment
- Upper Segment

When **Radio Std** is set to **J-STD-008**, or when **Radio Std** is set to **IS-97D IS-98D** and **Band Class** is set to **1 (1900 MHz)** or **4 (Korean PCS)** for **Base** tests, all of the measurement segments are effective for your selection:

- Lower Segment
- Lower Adj Segment
- Center Segment
- Upper Adj Segment
- Upper Segment

Figure 3-13 IS-95A Spur Close Measurement - Lower Segment View

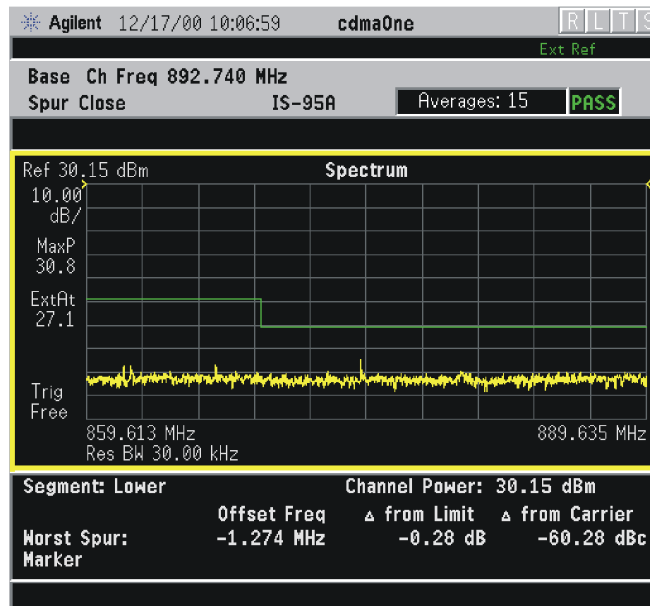
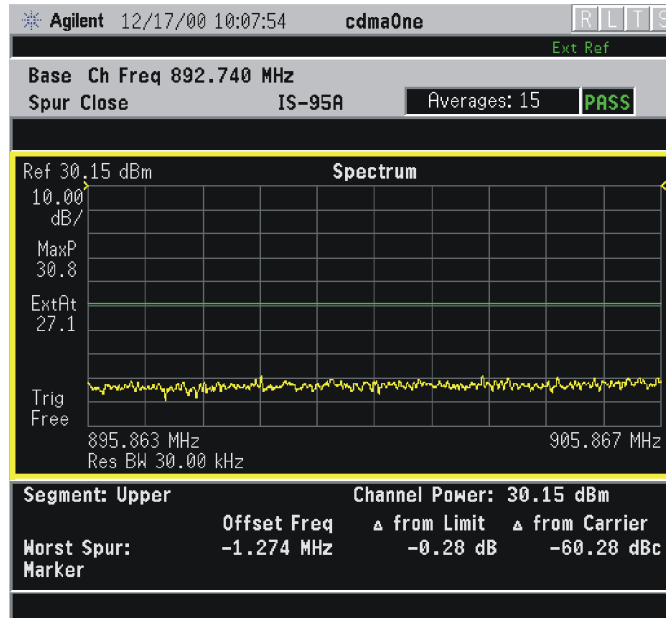

Figure 3-14 IS-95A Spur Close Measurement - Upper Segment View



Display Key Menu

Key Path: **Display**

- **AMPLITUDE Y Scale**

- **Scale/Div** - Allows you to enter a numeric value to change the vertical display sensitivity. The range is 0.10 to 20.00 dB with 0.01 dB resolution. The default setting is 10.00 dB. However, since the **Scale Coupling** default is **On**, this value is automatically determined by the measurement result. When you set a value manually, **Scale Coupling** automatically changes to **Off**.
- **Ref Value** - Allows you to set the absolute power reference value ranging from -250.00 to 250.00 dBm with 0.01 dB resolution. The default setting is 10.00 dBm. However, since the **Scale Coupling** default is **On**, this value is automatically determined by the measurement result. When you set a value manually, **Scale Coupling** automatically changes to **Off**.
- **Ref Position** - Allows you to set the reference position to either **Top**, **Ctr** (center), or **Bot** (bottom). The default setting is **Top**.
- **Scale Coupling** - Allows you to toggle the scale coupling function between **On** and **Off**. The default setting is **On**. Upon pressing the **Restart** front panel key or the **Restart** softkey under the **Meas Control** menu, this function automatically determines the scale per division and reference values based on the measurement results. When you set a value to either **Scale/Div** or **Ref Value** manually, **Scale Coupling** automatically changes to **Off**.

Marker Key Menu

Key Path: **Marker**

- **Select 1 2 3 4** - Allows you to activate up to four markers with the corresponding numbers, respectively. The selected number is underlined and its function is defined by pressing the **Function** key. The default is 1.
- **Normal** - Allows you to activate the selected marker to read the time position and amplitude of the marker on the Signal envelope trace, for example. Marker position is controlled by the **RPG** knob.
- **Delta** - Allows you to read the differences in time positions and amplitudes between the selected marker and the next.
- **Function** - Allows you to define the selected marker function to be **Band Power**, **Noise**, or **Off**. The default is **Off**. For measuring **Band Power**, you need to place the **Normal** marker and then place the **Delta** marker.
- **Trace** - Allows you to place the selected marker on the **Spectrum** trace.
- **Off** - Allows you to turn off the selected marker.
- **Shape Diamond** - Allows you to access the menu to define the selected marker shape to be **Diamond**, **Line**, **Square**, or **Cross**. The default is **Diamond**.
- **Marker All Off** - Allows you to turn off all of the markers.

The front panel **Search** key performs a peak search when pressed. A marker will automatically be activated at the highest peak.

Waveform (Time Domain) Keys

NOTE

You must have selected **Waveform** under the Key Path: **MEASURE** menu to access these menus.

Measurement Setup Key Menu

Key Path: **Meas Setup**

- **Sweep Time** - Specifies the measurement acquisition time which is used as the length of the time capture record. The range is 1.0 μ s and 100.0 s, depending upon the resolution bandwidth setting and the available internal memory size for acquisition points.
- **Meas Time** - Specifies the measurement acquisition time which is used as the length of the time capture record. The range is 10 ns and 100.0 s, depending upon the resolution bandwidth setting and the available internal memory size for acquisition points.

- **Res BW** - Sets the measurement bandwidth. The range is 10 Hz to 8 MHz using the Gaussian filter selected from RBW Filter under the Advanced menu, or 10 Hz to 10 MHz using the Flat top filter selected from RBW Filter. A larger bandwidth results in a larger number of acquisition points and reduces the maximum value allowed for the sweep time.
- **IF BW** - For PSA Option 122 or 140 only. Sets the measurement bandwidth. In wideband operation the range is 10 kHz to 80 MHz.(Option 122) or 10 kHz to 40 MHz (Option 140). The narrowband range is 10 Hz to 10 MHz. A larger bandwidth results in a larger number of acquisition points and reduces the maximum value allowed for the measurement time.
- **Wideband Setup** configures the wideband hardware path. This functionality is only available with the wideband options (122 or 140, PSA only).
 - **Wideband IF Gain** - Sets the gain for the wideband IF path. You must have selected **IF Path Wide**. Increasing the gain can increase the amplitude of small signals as long as you don't overdrive the hardware
 - **Wideband Filtering** - Accesses the menu to configure several aspects of the wideband filter.
 - Filter Type** - Selects **None** for no filtering, or **Raised Cosine**, **RRC** (root-raised cosine), **Nyquist**, **Root Nyquist**, **Gaussian** and **Flat Top**.
 - Filter Alpha** - Selects the filter alpha.
 - Filter BW** - Selects filter bandwidth. Bandwidth is not entered as a frequency. The value is entered as a ratio of the current instrument sampling rate (i.e. BW/sample rate).
 - **Sample Rate** - Allows arbitrary sample rates with 5 digits of resolution from 12.5 kHz to 100 MHz. Sample rate is coupled with the selected filter shape and bandwidth, and with the maximum available captured data.
 - **Block Size** - This key is for information only. Block size is coupled with the IF bandwidth and the measurement time.
 - **Wideband Advanced** - Accesses the advanced settings for the Option 122 wideband IF hardware path (PSA only).

NOTE

Parameters under the **Wideband Advanced** key seldom need to be changed. Any changes from the default advanced values may result in invalid measurement data.

- ADC Corr** Turning corrections on performs an ADC calibration to reduce the spectral image and applies the corrections.

- ❑ **IF Flat Corr** turns IF flatness corrections on and off for the Option 122 or 140 wideband IF. This control is independent of the narrowband IF flatness control.
 - ❑ **Analog Filter** manually selects the 80 MHz (Opt 122), 40 MHz (Opt 140), or 36 MHz anti-alias filter, which overrides the automatic selection of the bandwidth.
 - ❑ **WB ADC Dither** Toggles the ADC dither function on/off.. The “ADC dither” refers to the introduction of noise to the digitized steps of the analog-to-digital converter; the result is an improvement in amplitude accuracy. The wideband dither control does not affect the ADC dither in the narrowband IF path.
 - ❑ **Trig Interp** This is an advanced function that usually does not need to be changed. During normal operation trigger interpolation is on and the trigger offset is 0 seconds. At low sample rates the trigger interpolation can cause hardware unlock errors, so you may want to turn it off. You must have an external trigger source to use this functionality.
- **Average**
 - **Avg Number** - Changes the number of N averages.
 - **Avg Mode** - Toggles the averaging mode between **Exp** (exponential) and **Repeat**. This selection only effects on the averaging result after the number of N averages is reached. The N is set using the **Avg Number** key.
 - **Normal averaging:** Normal (linear) averaging is always used until the specified number of N averages is reached. When the **Measure** key under **Meas Control** is set to **Single**, data acquisition is stopped when the number of N averages is reached, thus **Avg Mode** has no effect in the single measurement mode.
 - **Exponential averaging:** When **Measure** is set to **Cont**, data acquisition will continue indefinitely. Exponential averaging is used with a weighting factor of N (the displayed count of averages stops at N). Exponential averaging weights new data more heavily than old data, which allows tracking of slow-changing signals. The weighting factor N is set using the **Avg Number** key.
 - **Repeat averaging:** When **Measure** is set to **Cont**, data acquisition will continue indefinitely. After the number of N averages is reached, all previous result data is cleared and the average count displayed is set back to 1. This is equivalent to being in **Measure Single** and pressing the **Restart** key each time the single measurement finishes.

- **Avg Type** - Accesses the menu of the following average types only for making spectrum (frequency domain) and waveform (time domain) measurements:
 - Pwr Avg (RMS)** - Executes the true power averaging which is calculated by averaging the rms voltage. This is the most accurate type.
 - Log-Pwr Avg (Video)** - Simulates the traditional spectrum analyzer type of averaging by calculating the log of the power. This type of averaging will underestimate the power when the signal is noise-like.
 - Voltage Avg** - Executes voltage averaging.
 - Maximum** - Captures peak voltage data. Simulates the traditional spectrum analyzer peak hold function.
 - Minimum** - Captures the minimum voltage data, similar to the maximum function.
- **Time Avg Num** - Changes the number of time averages to be made when using the Option 122 or 140 wideband hardware (PSA only). This averaging requires a frame trigger and is much faster than the standard averaging. This hardware averaging is done on the complex voltage time trace data before any measurement application averaging is done. Both types of averaging can be done on the same measurement data.

When time averaging is being done, each trace update represents N fresh data acquisitions averaged together, where N is the number of averages. You cannot access the individual time records that are being averaged in the hardware averager.

CAUTION If triggering is set incorrectly, averaged signal results can approach nil. “HW Average” is displayed when averaging is ON.

TIP If your measurement results vary or provide unexpected values, try turning Averaging OFF and execute single, non-averaged measurements to check your triggering setup. Press **Meas Control, Measure, Single** to make non-continuous measurements.

- **Trig Source**
Key path: **Meas Setup, Trig Source**
-

NOTE Changing the selection in the **Trig Source** menu alters the trigger source for the selected measurement only.

- **Free Run (Immediate)** - A trigger occurs at the time the data is requested, completely asynchronous with the RF or IF signal.

Key Reference
cdmaOne Measurement Keys

- **Video (Envlp)** - An internal IF envelope trigger that occurs at the absolute threshold level of the IF signal level.
- **RF Burst (Wideband)** - An internal wideband RF burst trigger that has the automatic level control for burst signals. It triggers at the level that is set relative to the peak RF signal (12 MHz bandwidth) input level. (Not available for Option 122 or 140 when using the wideband IF path.)
- **Ext Front** - Activates the front panel external trigger input (**EXT TRIGGER INPUT**) port. The external signal must be between -5.00 and $+5.00$ V with 1 or 10 mV resolution.
- **Ext Rear** - Activates the rear-panel external trigger input (**TRIGGER IN**) port. The external signal must be between -5.00 and $+5.00$ V with 1 or 10 mV resolution.
- **Frame** - Uses the internal frame clock to generate a trigger signal. The clock parameters are controlled under the **Mode Setup** key or the measurement firmware, but not both. Refer to the specific measurement section for details.
- **Line** - Sets the trigger to the internal line mode. Sweep triggers occur at intervals synchronous to the line frequency. See the specific measurement section for details.
- **IF Path** Only for PSA with Option B7J and either Option 122 or 140 installed. Selects either the standard narrowband IF hardware path or the wideband hardware path.
- **Restore Meas Defaults** - Presets only the settings that are specific to the selected measurement by pressing **Meas Setup, More (1 of 2), Restore Meas Defaults**. This will set the measure setup parameters, for the currently selected measurement only, to the factory defaults.
- **(Narrowband) Advanced** Accesses the menu to change the following parameters.

CAUTION

The advanced features should be used only if you are familiar with their operation. Changes from the default values may result in invalid data.

The **Narrowband** key label word is only present if you have Option B7J and either Option 122 or 140 installed. Parameters that are under the **(Narrowband) Advanced** key only affect the standard narrow band IF path. The wideband IF advanced functions are found under the **Wideband Advanced** key.

- **Pre-ADC BPF** - Toggles the pre-ADC bandpass filter function between **On** or **Off**. The default setting is **Off**. The pre-ADC bandpass filter is useful for rejecting nearby signals, so that sensitivity within the span range can be improved by increasing the ADC range gain.

- **RBW Filter** - Toggles the resolution bandwidth filter selection between **Flat** and **Gaussian**. If set to **Gaussian**, the filter provides more even time-domain response, particularly for “bursts”. If set to **Flat**, the filter provides a flatter bandwidth but is less accurate for “pulse responses”. A flat top filter also requires less memory and allows longer data acquisition times. For most waveform applications, the Gaussian filter is recommended. The resolution bandwidth range is 10 Hz to 8 MHz using the Gaussian filter or 10 Hz to 10 MHz using the Flat top filter.
- **ADC Range** - Accesses the menu to select one of the ADC ranging functions:
 - Auto** - Automatically adjusts the signal range for optimal measurement results.
 - AutoPeak** - Continuously searches for the highest peak signal.
 - AutoPeakLock** - Adjusts the range for the highest peak signal it identifies. It retains the range settings determined by that peak signal, even when the peak signal is no longer present.
 - Manual** - Accesses the selection menu of values, -6 to +24 dB for E4406A or None to +18 dB for PSA, to set the ADC range level. Also note that manual ranging is best for CW signals.
- **Data Packing** - Selects **Auto** (the default) or the **Short (16 bit)**, **Medium (24 bit)** and **Long (32 bit)** methods of data packing. The short, medium, and long methods are not compatible with all settings and should not be used unless you are familiar with data packing methods. **Auto** is the preferred choice.
 - Auto** - The data packing value most appropriate for current instrument settings is selected automatically.
 - Short (16 bit)** - Select this to pack data every 16 bits.
 - Medium (24 bit)** - Select this to pack data every 24 bits.
 - Long (32 bit)** - Select this to pack data every 32 bits.
- **ADC Dither** - Toggles the ADC dither function between **On** and **Off**. The default setting is **Off**. If set to **On**, the ADC dither refers to the introduction of noise to the digitized steps of the analog-to-digital converter, and results in better amplitude linearity and resolution in low level signals. However, it also results in reduced dynamic range by approximately 3 dB.
- **Decimation** - Toggles the decimation function between **On** and **Off**, and to set the decimation value. Decimation allows longer acquisition times for a given bandwidth by eliminating data points. Long time captures can be limited by the instrument data acquisition memory. Decimation numbers 1 to 4 describe the factor by which the number of points are reduced. The default setting is 1, which results in no data point reduction.

Table 3-7

Waveform (Time Domain) Measurement Defaults

Measurement Parameter	Factory Default Condition
Sweep Time	2.000 ms
Res BW	100.000 kHz2.00000 MHz
Averaging: Avg Number Avg Mode Avg Type	10; Off Exp Pwr Avg (RMS)
Trig Source	Free Run (Immediate)
IF Path (requires Option B7J and Option 122 or 140)	Narrow
Wideband IF Gain (Option 122 or 140)	0.00 dB
Wideband Filtering (Option 122 or 140) Filter Type Filter Alpha Filter BW	None 0.30 0.50
Signal Envelope View SPAN X Scale - Scale/Div AMPLITUDE Y Scale - Scale/Div	(for E4406A) 200.0 μ s 10.00 dB
RF Envelope View SPAN X Scale - Scale/Div AMPLITUDE Y Scale - Scale/Div	(for PSA) 200.0 μ s 10.00 dB
Linear Envelope View SPAN X Scale - Scale/Div Linear Envelope window: AMPLITUDE Y Scale - Scale/Div Phase window: AMPLITUDE Y Scale - Scale/Div	(for E4406A Option B7C) 200.0 μ s 100.0 mV 30.0 deg
I/Q Waveform View: SPAN X Scale -Scale/Div AMPLITUDE Y Scale - Scale/Div	200.0 μ s 100.0 mV
I and Q Waveform View: SPAN X Scale -Scale/Div AMPLITUDE Y Scale - Scale/Div	(for E4406A Option B7C) 200.0 μ s 100.0 mV
I/Q Polar View: I/Q Scale/Div I or Q Origin	(for E4406A) 100.0 mV 0.00 V
(Narrowband) Advanced	
Pre-ADC BPF	Off

Table 3-7 Waveform (Time Domain) Measurement Defaults

Measurement Parameter	Factory Default Condition
RBW Filter	Gaussian
ADC Range	Auto
Data Packing	Auto
ADC Dither	Off
Decimation	Off
Wideband Advanced (Option 122 or 140)	
ADC Correction	On
IF Flatness Corrections	On
Analog Filter	Auto, 80 MHz (Opt 122), 40 MHz (Opt 140)
WB ADC Dither	On
Trigger Interpolation	On

View/Trace Key Menu

Key Path: **View/Trace**

- **RF Envelope** (for E4406A) or **Signal Envelope** (for PSA) - Displays a time domain graph of the signal. The measured values for the mean power and peak-to-mean power are shown in the text window.

Figure 3-15 Waveform Measurement - RF Envelope (Default View)

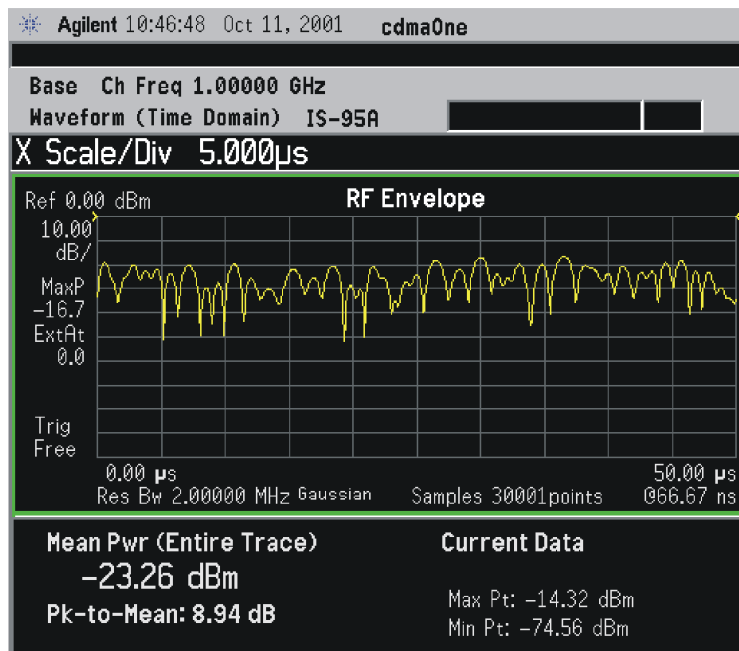
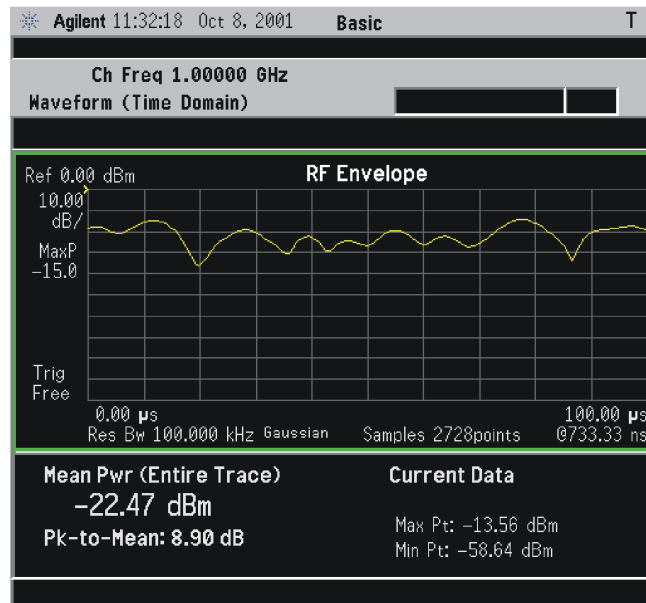
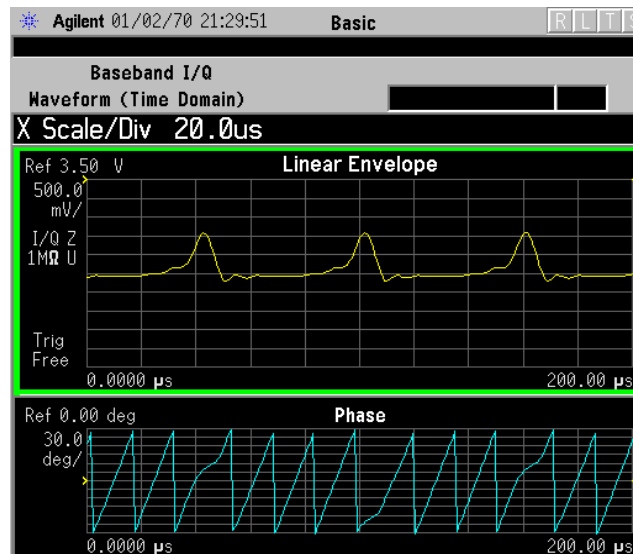

Figure 3-16 Waveform Measurement - RF Envelope (Default View)

*Meas Setup: Trace/View = RF Envelope,
Others = Factory default settings

*Input signal: cdma2000 Rev 8, SR1, 9 Channel

- **Linear Envelope** - (for E4406A Option B7C) Provides a combination view of a linear signal envelope graph and a phase graph with linear graticules. Use the **Next Window** and **Zoom** keys to select and enlarge either graph.

Figure 3-17 Waveform Measurement - Linear Envelope View

*Meas Setup: View/Trace = Linear Envelope View, GSM signal
Others = Factory defaults, except X and Y scales

- **I/Q Waveform** - Provides a view of the I and Q waveforms together on the same graph in parameters of voltage versus time in linear scale. Changes to sweep time or resolution bandwidth can affect data acquisition.

Figure 3-18 Waveform Measurement - I/Q Waveform View

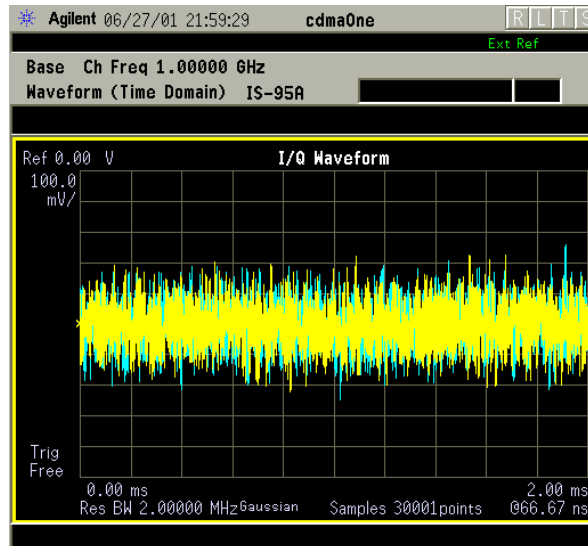

*Meas Setup: View/Trace = I/Q Waveform View
Others = Factory defaults, except X and Y scales

NOTE For the widest spans, the I/Q Waveform window becomes just “ADC time domain samples”, because the I/Q down-conversion is no longer in effect.

NOTE For the widest spans the I/Q Waveform window becomes just “ADC time domain samples”, because the I/Q down-conversion is no longer in effect.

Key Reference
cdmaOne Measurement Keys

- **I and Q Waveform** - (for E4406A Option B7C) Provides a combination view of the I and Q signal waveform graphs in the linear scales.

Figure 3-19 Waveform Measurement - I and Q Waveform View

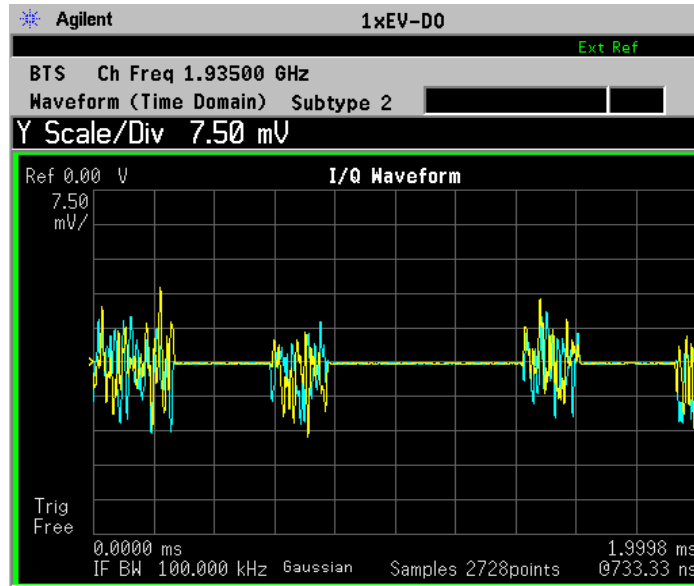

- **I/Q Polar** - (for E4406A) Provides a view of the I/Q signal in a polar vector graph.

Figure 3-20 Waveform Measurement - I/Q Polar View

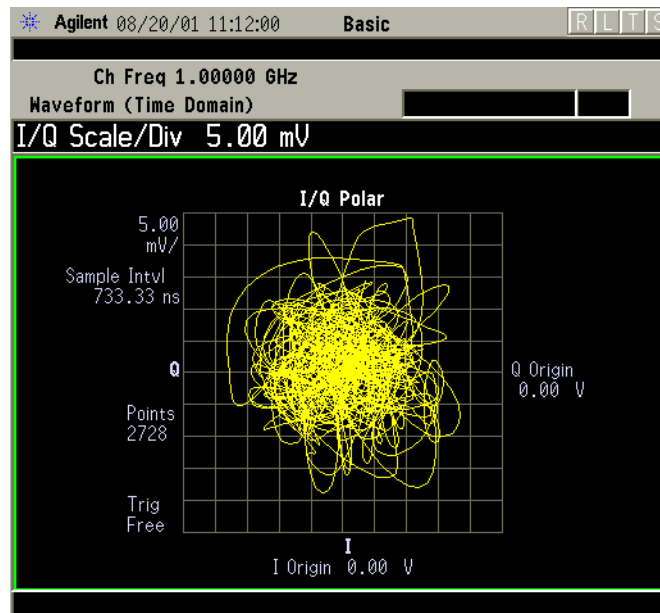

*Meas Setup: View/Trace = I/Q Polar View,
Others = Factory defaults, except X and Y scales

*Input signal: cdma2000 Rev 8, SR1, 9 Channel

- **Trace Display** - Press this key to access the trace selection menu. The currently selected trace type is shown on the **Trace Display** key.
 - **All** - Views both the current trace and the average trace.
 - **Average** - Views only the average trace (in blue color). See the **Meas Setup, Average** keys to select different types of averaging.
 - **Current** - Views only the trace (in yellow color) for the latest data acquisition.
 - **I Trace** - (for E4406A) Views only the I signal trace.
 - **Q Trace** - (for E4406A) Views only the Q signal trace.

SPAN X Scale Key Menu

Key Path: **Span X Scale**

NOTE

The **SPAN X Scale** key accesses the menu to modify the horizontal parameters common to the scaled windows for this measurement. Use the **Sweep Time** key under the **Meas Setup** menu to control the horizontal time span for this measurement:

- **Scale/Div** - Sets the horizontal scale by changing a time value per division. The range is 1.0 ns to 1.000 s per division with 0.01 ns resolution. The default setting is 200.0 μ s per division. However, since the **Scale Coupling** default is **On**, this value is automatically determined by the measurement result. When you set a value manually, **Scale Coupling** automatically changes to **Off**.
- **Ref Value** - Sets the reference value ranging from -1.0 to 10.0 s. The default setting is 0.00 s. However, since the **Scale Coupling** default is **On**, this value is automatically determined by the measurement result. When you set a value manually, **Scale Coupling** automatically changes to **Off**.
- **Ref Position** - Sets the reference position to either **Left**, **Ctr** (center) or **Right**. The default setting is **Left**.
- **Scale Coupling** - Toggles the scale coupling function between **On** and **Off**. The default setting is **On**. Upon pressing the **Restart** front-panel key or **Restart** softkey under the **Meas Control** menu, this function automatically determines the scale per division and reference values based on the measurement results. When you set a value to either **Scale/Div** or **Ref Value** manually, **Scale Coupling** automatically changes to **Off**.

NOTE

For E4406A, if the I/Q Polar window is active in the **I/Q Polar** view, the **SPAN X Scale** key accesses the following menu:

Key Reference

cdmaOne Measurement Keys

- **I/Q Scale/Div** - Sets the vertical and horizontal scales by changing a value per division. The range is 1.00 nV to 20.00 V per division. The default setting is 100.0 mV.
- **I or Q Origin** - Sets the reference value ranging from -250.00 to 250.00 V. The default setting is 0.00 V.

AMPLITUDE Y Scale Key Menu

Key Path: **AMPLITUDE Y Scale**

NOTE

If the **RF Envelope** (for PSA) or **Signal Envelope** (for E4406A) window is active in the **RF Envelope** (for PSA) or **Signal Envelope** (for E4406A) view, the **AMPLITUDE Y Scale** key accesses the following menu:

- **Scale/Div** - Sets the vertical scale by changing an amplitude value per division. The range is 0.10 to 20.00 dB per division with 0.01 dB resolution. The default setting is 10.00 dB per division. However, since the **Scale Coupling** default is **On**, this value is automatically determined by the measurement result. When you set a value manually, **Scale Coupling** automatically changes to **Off**.
- **Ref Value** - Sets the reference value ranging from -250.00 to 250.00 dBm. The default setting is 0.00 dBm. However, since the **Scale Coupling** default is **On**, this value is automatically determined by the measurement result. When you set a value manually, **Scale Coupling** automatically changes to **Off**.
- **Ref Position** - Sets the reference position to either **Top**, **Ctr** (center) or **Bot** (bottom). The default setting is **Top**.
- **Scale Coupling** - Toggles the scale coupling function between **On** and **Off**. The default setting is **On**. Upon pressing the **Restart** front-panel key or **Restart** softkey under the **Meas Control** menu, this function automatically determines the scale per division and reference values based on the measurement results. When you set a value to either **Scale/Div** or **Ref Value** manually, **Scale Coupling** automatically changes to **Off**.

NOTE

For E4406A with Option B7C, if the **Linear Envelope** window is active in the **Linear Envelope** view, the **AMPLITUDE Y Scale** key accesses the following menu:

- **Scale/Div** - Sets the vertical scale by changing an amplitude value per division. The range is 1.00 nV to 20.00 V per division. The default setting is 100.0 mV per division. However, since the **Scale Coupling** default is **On**, this value is automatically determined by the measurement result. When you set a value manually, **Scale Coupling** automatically changes to **Off**.
- **Ref Value** - Sets the reference value ranging from - 250.00 to 250.00 V. The default setting is 0.00 V. However, since the **Scale Coupling** default is **On**, this value is automatically determined by the measurement result. When you set a value manually, **Scale Coupling** automatically changes to **Off**.
- **Ref Position** - Sets the reference position to either **Top**, **Ctr** (center) or **Bot** (bottom). The default setting is **Top**.

Key Reference
cdmaOne Measurement Keys

- **Scale Coupling** - Toggles the scale coupling function between **On** and **Off**. The default setting is **On**. Upon pressing the **Restart** front-panel key or **Restart** softkey under the **Meas Control** menu, this function automatically determines the scale per division and reference values based on the measurement results. When you set a value to either **Scale/Div** or **Ref Value** manually, **Scale Coupling** automatically changes to **Off**.

NOTE

For E4406A with Option B7C, if the Phase window is active in the **Linear Envelope** view, the **AMPLITUDE Y Scale** key accesses the menu to modify the following parameters:

- **Scale/Div** - Sets the vertical scale by changing an amplitude value per division. The range is 0.10 to 3600.0 deg per division. The default setting is 30.00 deg. However, since the **Scale Coupling** default is **On**, this value is automatically determined by the measurement result. When you set a value manually, **Scale Coupling** automatically changes to **Off**.
- **Ref Value** - Sets the reference value ranging from -36000.0 to 36000.0 deg. The default setting is 0.00 deg. However, since the **Scale Coupling** default is **On**, this value is automatically determined by the measurement result. When you set a value manually, **Scale Coupling** automatically changes to **Off**.
- **Ref Position** - Sets the reference position to either **Top**, **Ctr** (center) or **Bot** (bottom). The default setting is **Ctr**.
- **Scale Coupling** - Toggles the scale coupling function between **On** and **Off**. The default setting is **On**. Upon pressing the **Restart** front-panel key or **Restart** softkey under the **Meas Control** menu, this function automatically determines the scale per division and reference values based on the measurement results. When you set a value to either **Scale/Div** or **Ref Value** manually, **Scale Coupling** automatically changes to **Off**.

NOTE

If the I/Q Waveform window is active in the **I/Q Waveform** view (or the I Waveform, or Q Waveform window is active in the **I and Q Waveform** view for E4406A with Option B7C), the **AMPLITUDE Y Scale** key accesses the menu to modify the following parameters:

- **Scale/Div** - Sets the vertical scale by changing an amplitude value per division. The range is 1.00 nV to 20.00 V per division. The default setting is 100.0 mV. However, since the **Scale Coupling** default is **On**, this value is automatically determined by the measurement result. When you set a value manually, **Scale Coupling** automatically changes to **Off**.
- **Ref Value** - Sets the reference value ranging from -250.00 to 250.00 V. The default setting is 0.00 V. However, since the **Scale Coupling**

default is **On**, this value is automatically determined by the measurement result. When you set a value manually, **Scale Coupling** automatically changes to **Off**.

- **Ref Position** - Sets the reference position to either **Top**, **Ctr** (center) or **Bot** (bottom). The default setting is **Ctr**.
- **Scale Coupling** - Toggles the scale coupling function between **On** and **Off**. The default setting is **On**. Upon pressing the **Restart** front-panel key or **Restart** softkey under the **Meas Control** menu, this function automatically determines the scale per division and reference values based on the measurement results. When you set a value to either **Scale/Div** or **Ref Value** manually, **Scale Coupling** automatically changes to **Off**.

NOTE

For E4406A, if the I/Q Polar window is active in the I/Q Polar view, the **SPAN X Scale** or **AMPLITUDE Y Scale** key accesses the menu to modify the following parameters:

- **I/Q Scale/Div** - Sets the vertical and horizontal scales by changing a value per division. The range is 1.00 nV to 20.00 V per division. The default setting is 100.0 mV.
- **I or Q Origin** - Sets the reference value ranging from -250.00 to 250.00 V. The default setting is 0.00 V.

Display Key Menu

The **Display** key is not available for this measurement.

Marker Key Menu

Key Path: **Marker**

The **Marker** front-panel key accesses the menu to configure the markers.

- **Select 1 2 3 4** - Activates up to four markers with the corresponding numbers, respectively. The selected number is underlined and its function is defined by pressing the **Function** key. The default is 1.
- **Normal** - Activates the selected marker to read the time position and amplitude of the marker on the RF envelope or Signal Envelope trace. Marker position is controlled by the **RPG** knob.
- **Delta** - Reads the differences in frequency and either time position or amplitude, between the selected marker and the next marker.
- **Function Off** - Selects the marker function to be **Band Power**, **Noise**, or **Off**. The default is **Off**. If set to **Band Power**, you need to select **Delta**.
- **Trace** - Places the selected marker on **RF Envelope** (for PSA), **Signal Envelope** (for E4406A), or **I/Q Waveform**. Also, for E4406A with Option B7C, you can place the marker on **Linear Envelope**, **Linear Phase**, **I Waveform**, or **Q Waveform**.

Key Reference
cdmaOne Measurement Keys

- **Off** - Turns off the selected marker.
- **Shape Diamond** - Accesses the menu to define the selected marker shape to be **Diamond**, **Line**, **Square**, or **Cross**. The default shape is **Diamond**.
- **Marker All Off** - Turns off all of the markers.

Peak Search Key

Key Path: **Search**

The front panel **Search** key performs a peak search when pressed. A marker will automatically be activated at the highest peak.

NOTE

In the Waveform measurement, the Mean Pwr (Entire Trace) value plus the Pk-to-Mean value will sum to equal the current Max Pt. value as shown in the data window below the RF Envelope or Signal Envelope display. If you do a marker peak search (**Search**) with averaging turned off, the marker will find the same maximum point. However, if you turn averaging on, the Pk-to-Mean value will use the highest peak found for any acquisition during averaging, while the marker peak will look for the peak of the display, which is the result of n-averages. This will usually result in differing values for the maximum point.

4

Programming Commands

These commands are only available when the cdmaOne mode has been selected using **INSTRument:SElect CDMA**. If cdmaOne mode is selected, commands that are unique to another mode are not available.

SCPI Command Subsystems

- “CALCulate Subsystem” on page 168
- “CONFigure Subsystem” on page 193
- “DISPlay Subsystem” on page 194
- “FETCh Subsystem” on page 204
- “FORMat Subsystem” on page 205
- “INITiate Subsystem” on page 207
- “INSTrument Subsystem” on page 209
- “MEASure Group of Commands” on page 213
- “READ Subsystem” on page 264
- “SENSe Subsystem” on page 265
- “TRIGger Subsystem” on page 334

Programming Command Compatibility Across Model Numbers and Across Modes

Across PSA Modes: Command Subsystem Similarities

When you select different modes you get different sets of available programming commands. That is, *only* the commands that are appropriate for the current mode are available. Also, some commands have the same syntax in different modes but have different ranges or settings that are only appropriate to the current mode.

The following table shows which command subsystems are the same across different modes. If there is no “X” by a particular subsystem, then the set of available commands is different in those modes. Command ranges or defaults may also be different. Refer to the programming command descriptions in the documentation for each mode for details.

Command Subsystem	Same command set is available: SA mode compared with the application modes: Digital Modulation, Basic, WLAN, W-CDMA, cdmaOne, cdma2000, 1xEV-DO, GSM, EDGE, NADC, PDC, or Measuring Receiver	Same command set is available: SA mode compared with the application modes: Phase Noise, Noise Figure, TD-SCDMA
IEEE common commands	X	X
ABORt	X	X
CALCulate		
CALibration	X	X
CONFigure		
COUPle	not available in these application modes	not available in these application modes
DISPlay		
FETCh		
FORMat		X
HCOPy	X	X
INITiate		

Command Subsystem	Same command set is available: SA mode compared with the application modes: Digital Modulation, Basic, WLAN, W-CDMA, cdmaOne, cdma2000, 1xEV-DO, GSM, EDGE, NADC, PDC, or Measuring Receiver	Same command set is available: SA mode compared with the application modes: Phase Noise, Noise Figure, TD-SCDMA
INPut	not available in these application modes	X
MEASure		
MEMory	X	X
MMEMory	X	X
MMEMory:STORe:TRACe	not available in these application modes	X
READ		
[SENSe] [SENSe:]CHANnel [SENSe:]CORRection [SENSe:]FEED [SENSe:]FREQuency:CE NTer [SENSe:]FREQuency: <other subsystems> [SENSe:]<measurement> [SENSe:]POWer [SENSe:]RADio [SENSe:]SYNC	X not available in these application modes	not available in these application modes
STATus	X	X
SYSTem	X	X
TRACe	not available in these application modes	X
TRIGger		
UNIT	X	X

Across PSA Modes: Specific Command Differences

Some programming commands operate differently depending on which Mode the analyzer is set to.

Command	Spectrum Analysis, Phase Noise and Noise Figure Mode	Basic, cdmaOne, cdma2000, 1xEV-DO, W-CDMA, GSM, EDGE, NADC, PDC Modes
CONFigure: <measurement>	Accesses the measurement and sets the instrument settings to the defaults. Averaging is turned on and set to 10. The instrument is put in single measurement mode. It does not initiate a measurement. Use INIT:IMM to make one measurement.	Accesses the measurement and sets the instrument settings to the defaults. If you were already in single measurement mode, it takes one measurement and then waits. If you were in continuous measurement mode it continues to measure.
*ESE default	Default is 255 which means that every error/status bit change that has occurred will be returned with a *ESR? query. You must set the value of *ESE to choose only the bits/status that you want returned.	Default is 0 which means that none of the error/status bit changes that have occurred will be returned with a *ESR? query. You must set the value of *ESE to choose the bits/status that you want returned.
TRIGger commands	For these modes, only one trigger source can be selected and it will be common across the modes. Also, only one value can be set for the trigger delay, level, or polarity.	For these modes, a unique trigger source can be selected for each mode. Also, each trigger source can have unique settings for the its delay, level, and polarity.
Saving and recalling traces	Traces can only be saved when in the Spectrum Analysis mode (MMEM:STOR:TRAC). This is because the instrument state must be saved along with the trace data and the state data varies depending on the number of modes currently available in the instrument.	

Using Applications in PSA Series vs. VSA E4406A

NOTE This information *only* applies to the application modes: Basic, cdmaOne, cdma2000, 1xEV-DO, W-CDMA, GSM, EDGE, NADC, and PDC.

Command	PSA Series	VSA E4406A: A.04.00	VSA E4406A: A.05.00
*RST	Resets instrument, putting it in continuous measurement mode. Use INIT:CONT OFF to select single measurement mode and INIT:IMM to start one measurement.	Resets instrument, putting it in single measurement mode. One measurement is initiated when the command is sent.	Resets instrument, putting it in single measurement mode. No measurement is initiated when the command is sent. Use INIT:IMM to start one measurement.
CONFigure: <measurement>	Accesses the measurement and sets the instrument settings to the defaults. If you were already in single measurement mode, it takes one measurement and then waits.	Same as PSA. Accesses the measurement and sets the instrument settings to the defaults. If you were already in single measurement mode, it takes one measurement and then waits.	Accesses the measurement and sets the instrument settings to the defaults. If you were already in single measurement mode, it does not initiate a measurement. Use INIT:IMM to make one measurement.
*ESE default	Default is 255 which means that every error/status bit change that has occurred will be returned with a *ESR? query. You must set the value of *ESE to choose only the bits/status that you want returned.	Default is 0 which means that none of the error/status bit changes that have occurred will be returned with a *ESR? query. You must set the value of *ESE to choose the bits/status that you want returned.	Same as VSA A.04.00. Default is 0 which means that none of the error/status bit changes that have occurred will be returned with a *ESR? query. You must set the value of *ESE to choose the bits/status that you want returned.
*LRN	The command is <i>not</i> available.	The command is available.	The command is available.

Command	PSA Series	VSA E4406A: A.04.00	VSA E4406A: A.05.00
TRIGger commands	<p>In Spectrum Analysis mode only one value can be set for the trigger's source, delay, level, or polarity.</p> <p>Basic, GSM, EDGE, cdmaOne, cdma2000, W-CDMA, NADC, PDC modes function the same as VSA</p>	<p>You can select a unique trigger source for each mode. Each trigger source can have unique settings for the delay, level, and polarity parameters.</p>	<p>Same as VSA A.04.00.</p> <p>You can select a unique trigger source for each mode. Each trigger source can have unique settings for the delay, level, and polarity parameters.</p>
AUTO ON OFF control and setting manual values	<p>We recommend that you set a function's automatic state to OFF, before you send it your manual value.</p> <p>Some functions will turn off the automatic mode when you send a specific manual value, but others will not. This also varies with the instrument model.</p>	<p>We recommend that you set a function's automatic state to OFF, before you send it your manual value.</p> <p>Some functions will turn off the automatic mode when you send a specific manual value, but others will not. This also varies with the instrument model.</p>	<p>We recommend that you set a function's automatic state to OFF, before you send it your manual value.</p> <p>Some functions will turn off the automatic mode when you send a specific manual value, but others will not. This also varies with the instrument model.</p>

CALCulate Subsystem

This subsystem is used to perform post-acquisition data processing. In effect, the collection of new data triggers the CALCulate subsystem. In this instrument, the primary functions in this subsystem are markers and limits.

The SCPI default for data output format is ASCII. The format can be changed to binary with FORMat:DATA which transports faster over the bus.

ACP - Limits

Adjacent Channel Power—Limit Test

```
:CALCulate:ACP:LIMit:STATe OFF|ON|0|1
```

```
:CALCulate:ACP:LIMit:STATe?
```

Turn limit test on or off.

Factory Preset: On

Remarks: For E4406A you must be in Basic, cdmaOne, iDEN mode to use this command. Use INSTRument:SElect to set the mode.

For PSA you must be in cdmaOne mode to use this command. Use INSTRument:SElect to set the mode.

Test Current Results Against all Limits

:CALCulate:CLIMits:FAIL?

Queries the status of the current measurement limit testing. It returns a 0 if the measured results pass when compared with the current limits. It returns a 1 if the measured results fail any limit tests.

Data Query

:CALCulate:DATA [n] ?

Returns the designated measurement data for the currently selected measurement and sub-opcode.

n = any valid sub-opcode for the current measurement. See the [“MEASure Group of Commands” on page 213](#) for information on the data that can be returned for each measurement.

For sub-opcodes that return trace data use the **:CALCulate:DATA [n] :COMPRESS?** command below.

Calculate/Compress Trace Data Query

:CALCulate:DATA<n>:COMPRESS?
BLOCK | CFIT | MAXimum | MINimum | MEAN | DMEan
| RMS | RMSCubed | SAMPLE | SDEVIation | PPHase
[, <soffset> [, <length> [, <roffset> [, <rlimit>]]]]

Returns compressed data for the specified trace data. The data is returned in the same units as the original trace and only works with the currently selected measurement. The command is used with a sub-opcode *<n>* since measurements usually return several types of trace data. See the following table for the sub-opcodes for the trace data names that are available in each measurement. For sub-opcodes that return scalar data use the **:CALCulate:DATA [n] ?** command above.

This command is used to compress or decimate a long trace to extract and return only the desired data. A typical example would be to acquire *N* frames of GSM data and return the mean power of the first burst in each frame. The command can also be used to identify the best curve fit for the data.

- **BLOCK** or block data - returns all the data points from the region of the trace data that you specify. For example, it could be used to return the data points of an input signal over several timeslots, excluding the portions of the trace data that you do not want.
- **CFIT** or curve fit - applies curve fitting routines to the data. *<soffset>* and *<length>* are required to define the data that you

want. <roffset> is an optional parameter for the desired order of the curve equation. The query will return the following values: the x-offset (in seconds) and the curve coefficients ((order + 1) values).

MIN, MAX, MEAN, DME, RMS, RMSC, SAMP, SDEV and PPH return one data value for each specified region (or <length>) of trace data, for as many regions as possible until you run out of trace data (using <roffset> to specify regions). Or they return the number regions you specify (using <rlimit>) ignoring any data beyond that.

- **MINimum** - returns the minimum data point for the specified region(s) of trace data. For I/Q trace data, the minimum magnitude of the I/Q pairs is returned.
- **MAXimum** - returns the maximum data point for the specified region(s) of trace data. For I/Q trace data, the maximum magnitude of the I/Q pairs is returned.
- **MEAN** - returns the arithmetic mean of the data point values for the specified region(s) of trace data. For I/Q trace data, the mean of the magnitudes of the I/Q pairs is returned. See the following equations.

Note: If the original trace data is in dB, this function returns the arithmetic mean of those log values, not log of the mean power, which is a more useful value.

Equation 4-1 Mean Value of Data Points for Specified Region(s)

$$\text{MEAN} = \frac{1}{n} \sum_{X_i \in \text{region(s)}} X_i$$

where X_i is a data point value, and n is the number of data points in the specified region(s).

Equation 4-2 Mean Value of I/Q Data Pairs for Specified Region(s)

$$\text{MEAN} = \frac{1}{n} \sum_{X_i \in \text{region(s)}} |X_i|$$

where $|X_i|$ is the magnitude of an I/Q pair, and n is the number of I/Q pairs in the specified region(s).

- **DMEan** - returns the mean power (in dB/dBm) of the data point values for the specified region(s) of trace data. See the following equation:

Figure 4-1 DMEan Value of Data Points for Specified Region(s)

$$DME = 10 \times \log_{10} \left(\frac{1}{n} \sum_{X_i \in \text{region}(s)} \left(\frac{X_i}{10} \right) \right)$$

- *RMS* - returns the arithmetic rms of the data point values for the specified region(s) of trace data. See the following equation.

For I/Q trace data, the rms of the magnitudes of the I/Q pairs is returned. See the following equation.

Note: This function is very useful for I/Q trace data. However, if the original trace data is in dB, this function returns the rms of the log values which is not usually needed.

Equation 4-3 RMS Value of Data Points for Specified Region(s)

$$RMS = \sqrt{\frac{1}{n} \sum_{X_i \in \text{region}(s)} X_i^2}$$

where X_i is a data point value, and n is the number of data points in the specified region(s).

Equation 4-4 RMS Value of I/Q Data Pairs for Specified Region(s)

$$RMS = \sqrt{\frac{1}{n} \sum_{X_i \in \text{region}(s)} X_i X_i^*}$$

where X_i is the complex value representation of an I/Q pair, X_i^* its conjugate complex number, and n is the number of I/Q pairs in the specified region(s).

Once you have the rms value for a region of I/Q trace data, you may want to calculate the mean power. You must convert this rms I/Q value (peak volts) to power in dB.

$$10 \times \log[10 \times (\text{rms value})^2]$$

- *RMSCubed* - returns the arithmetic rms of the cubed voltage normalized data point values for the specified region(s) of I/Q trace data by following the formula which is specifically defined for calculating the “Cubic Metric.” This formula is described in the 3GPP TS.25.101 release-7 document. The RMSCubed parameter can be used on any set of I/Q pairs (DATA0) with units of points, not

time.

Equation 4-5 RMSC Values of I/Q Data Pairs for Specified Region(s)

$$\begin{aligned} \text{RMSC} &= 20 \log \sqrt{\frac{1}{n} \sum_{X_i \in \text{region}(s)} \left\{ \frac{\sqrt{X_i X_i^*}}{\sqrt{\frac{1}{n} \sum_{X_i \in \text{region}(s)} X_i X_i^*}} \right\}^3}^2 \\ &= 20 \log n \sqrt{\sum_{X_i \in \text{region}(s)} \left(\frac{X_i X_i^*}{\sum_{X_i \in \text{region}(s)} X_i X_i^*} \right)^3} \end{aligned}$$

where X_i is the complex value representation of an I/Q pair, X_i^* its conjugate complex number, and n is the number of I/Q pairs in the specified region(s).

- *SAMPLE* - returns the first data value for the specified region(s) of trace data. For I/Q trace data, the first I/Q pair is returned.
- *SDEViation* - returns the arithmetic standard deviation for the data point values for the specified region(s) of trace data. See the following equation.

For I/Q trace data, the standard deviation of the magnitudes of the I/Q pairs is returned. See the following equation.

Equation 4-6 Standard Deviation of Data Point Values for Specified Region(s)

$$\text{SDEV} = \sqrt{\frac{1}{n} \sum_{X_i \in \text{region}(s)} (X_i - \bar{X})^2}$$

where X_i is a data point value, \bar{X} is the arithmetic mean of the data point values for the specified region(s), and n is the number of data points in the specified region(s).

Equation 4-7 Standard Deviation of I/Q Data Pair Values for Specified Region(s)

$$\text{SDEV} = \sqrt{\frac{1}{n} \sum_{X_i \in \text{region}(s)} (|X_i| - \bar{X})^2}$$

where $|X_i|$ is the magnitude of an I/Q pair, X is the mean of the magnitudes for the specified region(s), and n is the number of data points in the specified region(s).

- *PPHase* - returns the pairs of rms power (dBm) and arithmetic mean phase (radian) for every specified region and frequency offset (Hz). The number of pairs is defined by the specified number of regions. The command can be used for I/Q vector ($n=0$) in Waveform (time domain) measurement and all parameters are specified by data point in PPH.

The rms power of the specified region may be expressed as:

$$\text{Power} = 10 \times \log [10 \times (\text{RMS I/Q value})] + 10.$$

$$\text{The RMS I/Q value (peak volts)} = \sqrt{\frac{1}{n} \sum_{X_i \in \text{region}} X_i X_i^*}$$

where X_i is the complex value representation of an I/Q pair, X_i^* its conjugate complex number, and n is the number of I/Q pairs in the specified region.

The arithmetic mean phase of the specified region may be expressed as:

$$\text{Phase} = \frac{1}{n} \sum_{Y_i \in \text{region}} Y_i$$

Where Y_i is the unwrapped phase of I/Q pair with applying frequency correction and n is the number of I/Q pairs in the specified region.

The frequency correction is made by the frequency offset calculated by the arithmetic mean of every specified region's frequency offset. Each frequency offset is calculated by the least square method against the unwrapped phase of I/Q pair.

Figure 4-2 Sample Trace Data - Constant Envelope

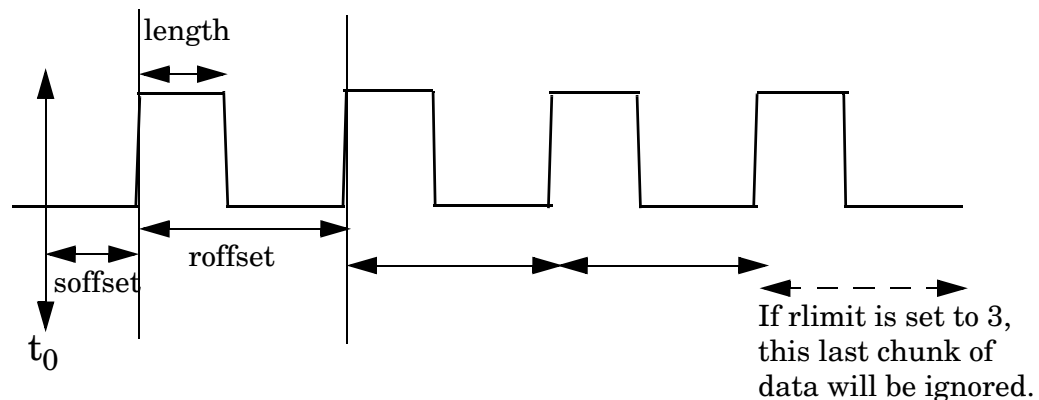
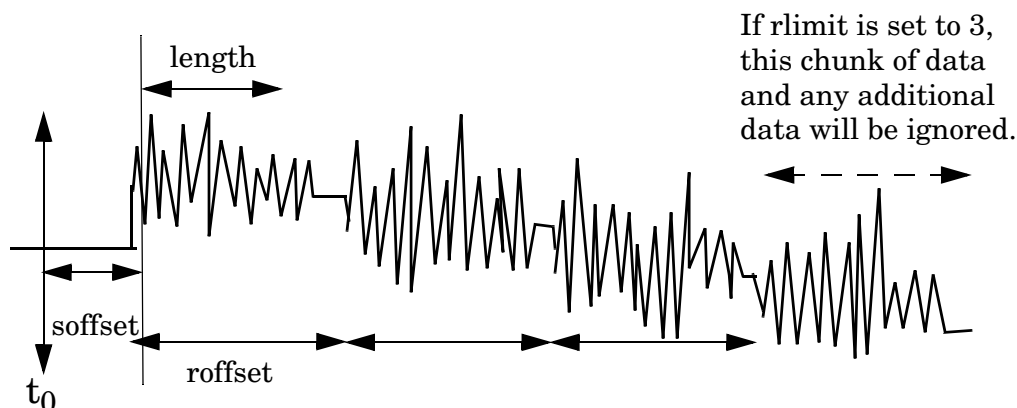

Figure 4-3 Sample Trace Data - Not Constant Envelope



<offset> - start offset is an optional real number (in seconds). It specifies the amount of data at the beginning of the trace that will be ignored before the decimation process starts. It is the time from the start of the trace to the point where you want to start using the data. The default value is zero.

<length> - is an optional real number (in seconds). It defines how much data will be compressed into one value. This parameter has a default value equal to the current trace length.

<roffset> - repeat offset is an optional real number (in seconds). It defines the beginning of the next field of trace elements to be compressed. This is relative to the beginning of the previous field. This parameter has a default value equal to the <length> variable.

<rlimit> - repeat limit is an optional integer. It specifies the number of data items that you want returned. It will ignore any additional items beyond that number. You can use the Start offset and the Repeat limit to pick out exactly what part of the data you want to use. The default value is all the data.

Example: To query the mean power of a set of GSM bursts:

1. Set the waveform measurement sweep time to acquire at least one burst.
2. Set the triggers such that acquisition happens at a known position relative to a burst.
3. Then query the mean burst levels using, **CALC:DATA2:COMP? MEAN, 24e-6, 526e-6** (These parameter values correspond to GSM signals, where 526e-6 is the length of the burst in the slot and you just want 1 burst.)

NOTE

There is a more detailed example in the “Improving the Speed of Your Measurements” section in the PSA Series *User’s and Programmer’s*

Reference. There is also a sample program in the Programming Fundamentals chapter of that book, and a copy of it is on the documentation CD-ROM.

NOTE There is a more detailed example in the “Improving the Speed of Your Measurements” section in the E4406A *Programmer’s Guide*. There is also a sample program in the Programming Fundamentals chapter of that book, and a copy of it is on the documentation CD-ROM.

Remarks: The optional parameters must be entered in the specified order. For example, if you want to specify <length>, you must also specify <soffset>.

This command uses the data in the format specified by FORMat:DATA, returning either binary or ASCII data.

History: Added in revision A.03.00
Changed in revision A.05.00

Measurement	Available Traces	Markers Available?
ACP - adjacent channel power (Basic, cdmaOne, cdma2000, W-CDMA, iDEN, WiDEN, NADC, PDC modes)	no traces (n=0) ^a for I/Q points	no markers
BER - bit error rate (iDEN, WiDEN mode)	no traces (n=0) ^a for I/Q data	no markers
CDPower - code domain power (cdmaOne mode)	POWer (n=2) ^a TIMing (n=3) ^a PHASe (n=4) ^a (n=0) ^a for I/Q points	yes
CDPower - code domain power (cdma2000 mode)	CDPower (n=2) ^a EVM (n=5) ^a MERRor (n=6) ^a PERRor (n=7) ^a SPOWer (n=9) ^a CPOWer (n=10) ^a (n=0) ^a for I/Q points	yes

Measurement	Available Traces	Markers Available?
CDPower - code domain power (W-CDMA mode)	CDERror ($n=13$) ^a CDPOwer ($n=2$) ^a EVM ($n=5$) ^a MERRor ($n=6$) ^a PERRor ($n=7$) ^a SPOWer ($n=9$) ^a CPOWer ($n=10$) ^a ($n=0$) ^a for I/Q points	yes
CHPower - channel power (Basic, cdmaOne, cdma2000, W-CDMA modes)	SPECtrum ($n=2$) ^a ($n=0$) ^a for I/Q points	no markers
CSPur - spurs close (cdmaOne mode)	SPECtrum ($n=2$) ^a ULIMit ($n=3$) ^a ($n=0$) ^a for I/Q points	yes
EEVM - EDGE error vector magnitude (EDGE mode)	EVMerror ($n=2$) ^a MERRor ($n=3$) ^a PERRor ($n=4$) ^a ($n=0$) ^a for I/Q points	yes
EORFspectr - EDGE output RF spectrum (EDGE mode)	RFEMod ($n=2$) ^a RFESwitching ($n=3$) ^a SPEMod ($n=4$) ^a LIMMod ($n=5$) ^a ($n=0$) ^a for I/Q points	yes, only for a single offset yes, only for multiple offsets
EPVTime - EDGE power versus time (EDGE mode)	RFENvelope ($n=2$) ^a UMASk ($n=3$) ^a LMASk ($n=4$) ^a ($n=0$) ^a for I/Q points	yes

Measurement	Available Traces	Markers Available?
ETSPur - EDGE transmit band spurs (EDGE mode)	SPECTrum ($n=2$) ^a ULIMit ($n=3$) ^a ($n=0$) ^a for I/Q points	yes
EVM - error vector magnitude (NADC, PDC modes)	EVM ($n=2$) ^a MERRor ($n=3$) ^a PERRor ($n=4$) ^a ($n=0$) ^a for I/Q points	yes
EVMQpsk - QPSK error vector magnitude (cdma2000, W-CDMA modes)	EVM ($n=2$) ^a MERRor ($n=3$) ^a PERRor ($n=4$) ^a ($n=0$) ^a for I/Q points	yes
IM - intermodulation (cdma2000, W-CDMA modes)	SPECTrum ($n=2$) ^a ($n=0$) ^a for I/Q points	yes
MCPower - multi-carrier power (W-CDMA mode)	no traces ($n=0$) ^a for I/Q points	no markers
OBW - occupied bandwidth (cdmaOne, cdma2000, iDEN, WiDEN, PDC, W-CDMA modes)	no traces ($n=0$) ^a for I/Q points	no markers
ORFSpectrum - output RF spectrum (GSM, EDGE mode)	RFEMod ($n=2$) ^a RFESwitching ($n=3$) ^a SPEMod ($n=4$) ^a LIMMod ($n=5$) ^a ($n=0$) ^a for I/Q points	yes, only for a single offset yes, only for multiple offsets
PFERror - phase and frequency error (GSM, EDGE mode)	PERRor ($n=2$) ^a PFERror ($n=3$) ^a RFENvelope ($n=4$) ^a ($n=0$) ^a for I/Q points	yes

Measurement	Available Traces	Markers Available?
PStatistic - power statistics CCDF (Basic, cdma2000, W-CDMA modes)	MEASured ($n=2$) ^a GAUSian ($n=3$) ^a REFerence ($n=4$) ^a ($n=0$) ^a for I/Q points	yes
PVTime - power versus time (GSM, EDGE, Service modes)	RFENvelope ($n=2$) ^a UMASk ($n=3$) ^a LMASk ($n=4$) ^a ($n=0$) ^a for I/Q points	yes
RHO - modulation accuracy (cdmaOne, cdma2000 mode)	($n=0$) ^a for I/Q points EVM ($n=2$) ^a MERRor ($n=3$) ^a PERRor ($n=4$) ^a ($n=0$) ^a for I/Q points	yes
RHO - modulation accuracy (W-CDMA mode)	($n=0$) ^a for I/Q points CDPower ($n=8$) EVM ($n=2$) ^a MERRor ($n=3$) ^a PERRor ($n=4$) ^a ($n=0$) ^a for I/Q points	yes
SEMask - spectrum emissions mask (cdma2000, W-CDMA mode)	SPECtrum ($n=2$) ^a ($n=0$) ^a for I/Q points	yes
TSPur - transmit band spurs (GSM, EDGE mode)	SPECtrum ($n=2$) ^a ULIMit ($n=3$) ^a ($n=0$) ^a for I/Q points	yes
TXPower - transmit power (GSM, EDGE mode)	RFENvelope ($n=2$) ^a IQ ($n=8$) ^a ($n=0$) ^a for I/Q points	yes

Measurement	Available Traces	Markers Available?
SPECTrum - (frequency domain) (all modes)	RFENvelope ($n=2$) ^a for Service mode IQ ($n=3$) ^a SPECTrum ($n=4$) ^a ASPECTrum ($n=7$) ^a ($n=0$) ^a for I/Q points	yes
WAVEform - (time domain) (all modes)	RFENvelope ($n=2$) ^a (also for Signal Envelope trace) IQ ($n=5$) ^a ($n=0$) ^a for I/Q points	yes

- a. The n number indicates the sub-opcode that corresponds to this trace. Detailed descriptions of the trace data can be found in the MEASure subsystem documentation by looking up the sub-opcode for the appropriate measurement.

Calculate Peaks of Trace Data

```
:CALCulate:DATA<n>:PEAKs?
<threshold>, <excursion> [, AMPLitude | FREQuency | TIME]
```

Returns a list of peaks for the designated trace data n for the currently selected measurement. The peaks must meet the requirements of the peak threshold and excursion values.

The command can only be used with specific $\langle n \rangle$ (sub-opcode) values, for measurement results that are trace, or scalar, data. See the table above for the appropriate sub-opcodes. Both real and complex traces can be searched, but complex traces are converted to magnitude in dBm. Sub-opcode $n=0$, is the raw trace data which cannot be searched for peaks. Sub-opcode $n=1$, is the scaler data which also cannot be searched for peaks.

Threshold - is the level below which trace data peaks are ignored

Excursion - To be defined as a peak, the signal must rise above the threshold by a minimum amplitude change (excursion). Excursion is measured from the lowest point above the threshold (of the rising edge of the peak), to the highest signal point that begins the falling edge. If a signal valley is higher than the threshold, then the excursion is referenced to that valley, and a peak is only defined if

the signal following that valley exceeds the excursion.

Amplitude - lists the peaks in order of descending amplitude, so the highest peak is listed first. This is the default peak order listing if the optional parameter is not specified.

Frequency - lists the peaks in order of occurrence, left to right across the x-axis

Time - lists the peaks in order of occurrence, left to right across the x-axis

Example: Select the spectrum measurement.

Use `CALC:DATA4:PEAK? -40,10,FREQ` to identify the peaks above -40 dBm, with excursions of at least 10 dB, in order of increasing frequency.

Query Results: Returns a list of floating-point numbers. The first value in the list is the number of peak points that follow. A peak point consists of two values: a peak amplitude followed by the its corresponding frequency (or time).

If no peaks are found the peak list will consist of only the number of peaks, (0).

The peak list is limited to 100 peaks. Peaks in excess of 100 are ignored.

Remarks: This command uses the data setting specified by the `FORMat:DATA` command and can return real 32-bit, real 64-bit, or ASCII data. The default data format is ASCII.

History: For E4406A:
Added in revision A.03.00 and later

CALCulate:MARKers Subsystem

Markers can be put on your displayed measurement data to supply information about specific points on the data. Some of the things that markers can be used to measure include: precise frequency at a point, minimum or maximum amplitude, and the difference in amplitude or frequency between two points.

When using the marker commands you must specify the measurement in the SCPI command. We recommend that you use the marker commands only on the current measurement. Many marker commands will return invalid results, when used on a measurement that is not current. (This is true for commands that do more than simply setting or querying an instrument parameter.) No error is reported for these invalid results.

You must make sure that the measurement is completed before trying to query the marker value. Using the MEASure or READ command, before the marker command, forces the measurement to complete before allowing the next command to be executed.

Each measurement has its own instrument state for marker parameters. Therefore, if you exit the measurement, the marker settings in each measurement are saved and are then recalled when you change back to that measurement.

Basic Mode - <measurement> key words

- ACPr - no markers (E4406A only)
- CHPower - no markers (E4406A only)
- PStatistic - markers available (E4406A only)
- SPECTrum - markers available
- WAVEform - markers available

Service Mode - <measurement> key words

- PVTime - no markers
- SPECTrum - markers available
- WAVEform - markers available

1xEV-DO Mode - <measurement> key words

- CDPower - markers available
- CHPower - no markers
- EVMQpsk - markers available
- IM - markers available
- OBW - no markers
- PStatistic - markers available
- PVTime - markers available
- RHO - markers available

- SEMask - markers available
- SPECTrum - markers available
- WAVeform - markers available

cdmaOne Mode - <measurement> key words

- ACPr - no markers
- CHPower - no markers
- CDPower - markers available
- CSPur - markers available
- RHO - markers available
- SPECTrum - markers available
- WAVeform - markers available

cdma2000 Mode - <measurement> key words

- ACP - no markers
- CDPower - markers available
- CHPower - no markers
- EVMQpsk - markers available
- IM - markers available
- OBW - no markers
- PStatistic - markers available
- RHO - markers available
- SEMask - markers available
- SPECTrum - markers available
- WAVeform - markers available

GSM (with EDGE) Mode - <measurement> key words

- EEVM - markers available
- EORFSpectr - markers available
- EPVTime - no markers
- ETSPur - markers available
- ORFSpectrum - markers available
- PFERror - markers available
- PVTime - no markers
- SPECTrum - markers available
- TSPur - markers available
- TXPower - no markers
- WAVeform - markers available

GSM Mode - <measurement> key words

- ORFSpectrum - markers available
- PFERror - markers available
- PVTime - no markers
- SPECTrum - markers available
- TSPur - markers available
- TXPower - no markers
- WAVeform - markers available

iDEN Mode - <measurement> key words

- ACP - no markers
- BER - no markers
- OBW - no markers
- SPECTrum - markers available
- WAVeform - markers available

NADC Mode - <measurement> key words

- ACP - no markers
- EVM - markers available
- SPECTrum - markers available
- WAVeform - markers available

PDC Mode - <measurement> key words

- ACP - no markers
- EVM - markers available
- OBW - no markers
- SPECTrum - markers available
- WAVeform - markers available

W-CDMA Mode - <measurement> key words

- ACP - no markers
- CDPower - markers available
- CHPower - no markers
- EVMQpsk - markers available
- IM - markers available
- MCPower - no markers
- OBW - no markers
- PStatistic - markers available
- RHO - markers available
- SEMask - markers available
- SPECTrum - markers available
- WAVeform - markers available

Example:

Suppose you are using the Spectrum measurement in your measurement personality. To position marker 2 at the maximum peak value of the trace that marker 2 is currently on, the command is:

```
:CALCulate:SPECTrum:MARKer2:MAXimum
```

You must make sure that the measurement is completed before trying to query the marker value. Use the MEASure or READ command before using the marker command. This forces the measurement to complete before allowing the next command to be executed.

Markers All Off on All Traces

:CALCulate:<measurement>:MARKer:AOff

Turns off all markers on all the traces in the specified measurement.

Example: **CALC:SPEC:MARK:AOff**

Remarks: The keyword for the current measurement must be specified in the command. (Some examples include: SPECTrum, WAVeform)

Front Panel

Access: **Marker, More, Marker All Off**

Marker Function Result

:CALCulate:<measurement>:MARKer [1] | 2 | 3 | 4:FUNCTION:RESult?

Queries the result of the currently active marker function. The measurement must be completed before querying the marker. A particular measurement may not have all the types of markers available.

The marker must have already been assigned to a trace. Use

:CALCulate:<measurement>:MARKer [1] | 2 | 3 | 4:TRACe to assign a marker to a particular trace.

Example: **CALC:SPEC:MARK:FUNC:RES?**

Remarks: The keyword for the current measurement must be specified in the command. (Some examples include: SPECTrum, WAVeform)

Front Panel

Access: **Marker, Marker Function**

Marker Peak (Maximum) Search

:CALCulate:<measurement>:MARKer [1] | 2 | 3 | 4:MAXimum

Places the selected marker on the highest point on the trace that is assigned to that particular marker number.

The marker must have already been assigned to a trace. Use

:CALCulate:<measurement>:MARKer [1] | 2 | 3 | 4:TRACe to assign a marker to a particular trace.

Example: **CALC:SPEC:MARK1:MAX**

Remarks: The keyword for the current measurement must be specified in the command. (Some examples include: SPECTrum, WAVeform)

Front Panel
Access: **Search**

Marker Peak (Minimum) Search

:CALCulate:<measurement>:MARKer [1] | 2 | 3 | 4:MINimum

Places the selected marker on the lowest point on the trace that is assigned to that particular marker number.

The marker must have already been assigned to a trace. Use **:CALCulate:<measurement>:MARKer [1] | 2 | 3 | 4:TRACe** to assign a marker to a particular trace.

Example: **CALC:SPEC:MARK2 MIN**

Remarks: The keyword for the current measurement must be specified in the command. (Some examples include: SPECTrum, WAVeform)

Marker Mode

E4406A (all modes):

PSA Series (Basic, cdmaOne, cdma2000, W-CDMA, GSM/EDGE, NADC, PDC modes):

**:CALCulate:<measurement>:MARKer [1] | 2 | 3 | 4:MODE
POSition|DELTA**

ESA/PSA Series (Phase Noise mode only):

**:CALCulate:<measurement>:MARKer [1] | 2 | 3 | 4:MODE
POSition|DELTA
|RMSDegree|RMSRadian|RFM|RMSJitter|OFF**

:CALCulate:<measurement>:MARKer [1] | 2 | 3 | 4:MODE?

E4406A/PSA: Selects the type of marker to be a normal position-type marker or a delta marker. A specific measurement may not have both types of markers. For example, several measurements only have position markers

ESA/PSA Phase Noise Mode: Selects the type of marker to be a normal position-type marker, a delta marker or an RMS measurement marker.

The marker must have already been assigned to a trace. Use **:CALCulate:<measurement>:MARKer [1] | 2 | 3 | 4:TRACe** to assign a marker to a particular trace.

Example: **CALC:SPEC:MARK:MODE DELTA**

Remarks: For the delta mode only markers 1 and 2 are valid.

The keyword for the current measurement must be specified in the command. (Some examples include: SPECTrum, WAVeform)

Front Panel

Access: **Marker, Marker [Delta]**

Marker On/Off

```
:CALCulate:<measurement>:MARKer [1] | 2 | 3 | 4 [:STATe] OFF | ON | 0 | 1
```

```
:CALCulate:<measurement>:MARKer [1] | 2 | 3 | 4 [:STATe] ?
```

Turns the selected marker on or off.

The marker must have already been assigned to a trace. Use

`:CALCulate:<measurement>:MARKer [1] | 2 | 3 | 4 :TRACe` to assign a marker to a particular trace.

Example: `CALC:SPEC:MARK2: on`

Remarks: The keyword for the current measurement must be specified in the command. (Some examples include: SPECTrum, AREFERENCE, WAVeform)

The WAVeform measurement only has two markers available.

Front Panel

Access: **Marker, Select then Marker Normal or Marker On Off**

Marker to Trace

```
:CALCulate:<measurement>:MARKer [1] | 2 | 3 | 4 :TRACe <trace_name>
```

```
:CALCulate:<measurement>:MARKer [1] | 2 | 3 | 4 :TRACe?
```

Assigns the specified marker to the designated trace. Not all types of measurement data can have markers assigned to them.

Example: With the WAVeform measurement selected, a valid command is `CALC:SPEC:MARK2:TRACE rfenvelope`.

Range: The names of valid traces are dependent upon the selected measurement. See the following table for the available trace names. The trace name assignment is independent of the marker number.

Remarks: The keyword for the current measurement must be specified in the command. (Some examples include: SPECTrum, WAVeform)

Front Panel

Access: **Marker, Marker Trace**

Measurement	Available Traces	Markers Available?
ACP - adjacent channel power (Basic, cdmaOne, cdma2000, W-CDMA, iDEN (E4406A only), NADC, PDC modes)	no traces $(n=0)^a$ for I/Q points	no markers
BER - bit error rate (iDEN mode, E4406A only)	no traces $(n=0)^a$ for I/Q data	no markers
CDPower - code domain power (cdmaOne mode)	POWer $(n=2)^a$ TIMing $(n=3)^a$ PHASe $(n=4)^a$ $(n=0)^a$ for I/Q points	yes
CDPower - code domain power (cdma2000, W-CDMA, 1xEV-DO modes)	CDPower $(n=2)^a$ EVM $(n=5)^a$ MERRor $(n=6)^a$ PERRor $(n=7)^a$ SPOWer $(n=9)^a$ CPOWer $(n=10)^a$ $(n=0)^a$ for I/Q points	yes
CHPower - channel power (Basic, cdmaOne, cdma2000, W-CDMA, 1xEV-DO modes)	SPECtrum $(n=2)^a$ $(n=0)^a$ for I/Q points	no markers
CSPur - spurs close (cdmaOne mode)	SPECtrum $(n=2)^a$ ULIMit $(n=3)^a$ $(n=0)^a$ for I/Q points	yes
EEVM - EDGE error vector magnitude (EDGE mode)	EVMError $(n=2)^a$ MERRor $(n=3)^a$ PERRor $(n=4)^a$ $(n=0)^a$ for I/Q points	yes

Measurement	Available Traces	Markers Available?
EORFspectr - EDGE output RF spectrum (EDGE mode)	RFEMod ($n=2$) ^a RFESwitching ($n=3$) ^a SPEMod ($n=4$) ^a LIMMod ($n=5$) ^a ($n=0$) ^a for I/Q points	yes, only for a single offset yes, only for multiple offsets
EPVTime - EDGE power versus time (EDGE mode)	RFENvelope ($n=2$) ^a UMASk ($n=3$) ^a LMASk ($n=4$) ^a ($n=0$) ^a for I/Q points	yes
ETSPur - EDGE transmit band spurs (EDGE mode)	SPECtrum ($n=2$) ^a ULIMit ($n=3$) ^a ($n=0$) ^a for I/Q points	yes
EVM - error vector magnitude (NADC, PDC modes)	EVM ($n=2$) ^a MERRor ($n=3$) ^a PERRor ($n=4$) ^a ($n=0$) ^a for I/Q points	yes
EVMQpsk - QPSK error vector magnitude (cdma2000, W-CDMA, 1xEV-DO modes)	EVM ($n=2$) ^a MERRor ($n=3$) ^a PERRor ($n=4$) ^a ($n=0$) ^a for I/Q points	yes
IM - intermodulation (cdma2000, W-CDMA, 1xEV-DO modes)	SPECtrum ($n=2$) ^a ($n=0$) ^a for I/Q points	yes
MCPower - multi-carrier power (W-CDMA mode)	no traces ($n=0$) ^a for I/Q points	no markers
OBW - occupied bandwidth (cdmaOne, cdma2000, iDEN (E4406A only), PDC, W-CDMA, 1xEV-DO modes)	no traces ($n=0$) ^a for I/Q points	no markers

Measurement	Available Traces	Markers Available?
ORFSpectrum - output RF spectrum (GSM, EDGE mode)	RFEMod ($n=2$) ^a RFESwitching ($n=3$) ^a SPEMod ($n=4$) ^a LIMMod ($n=5$) ^a ($n=0$) ^a for I/Q points	yes, only for a single offset yes, only for multiple offsets
PFERror - phase and frequency error (GSM, EDGE mode)	PERRor ($n=2$) ^a PFERror ($n=3$) ^a RFENvelope ($n=4$) ^a ($n=0$) ^a for I/Q points	yes
PStatistic - power statistics CCDF (Basic, cdma2000, W-CDMA, 1xEV-DO modes)	MEASured ($n=2$) ^a GAUSsian ($n=3$) ^a REFerence ($n=4$) ^a ($n=0$) ^a for I/Q points	yes
PVTime - power versus time (GSM, EDGE, 1xEV-DO, Service (E4406A only) modes)	RFENvelope ($n=2$) ^a UMASk ($n=3$) ^a LMASk ($n=4$) ^a ($n=0$) ^a for I/Q points	yes
RHO - modulation quality (cdmaOne, cdma2000, W-CDMA, 1xEV-DO mode)	($n=0$) ^a for I/Q points EVM ($n=2$) ^a MERRor ($n=3$) ^a PERRor ($n=4$) ^a ($n=0$) ^a for I/Q points	yes
SEMask - spectrum emissions mask (cdma2000, W-CDMA, 1xEV-DO mode)	SPECtrum ($n=2$) ^a ($n=0$) ^a for I/Q points	yes
TSPur - transmit band spurs (GSM, EDGE mode)	SPECtrum ($n=2$) ^a ULIMit ($n=3$) ^a ($n=0$) ^a for I/Q points	yes

Measurement	Available Traces	Markers Available?
TXPower - transmit power (GSM, EDGE mode)	RFENvelope ($n=2$) ^a IQ ($n=8$) ^a ($n=0$) ^a for I/Q points	yes
SPECTrum - (frequency domain) (all modes)	RFENvelope ($n=2$) ^a for Service mode (E4406A only) IQ ($n=3$) ^a SPECTrum ($n=4$) ^a ASPECTrum ($n=7$) ^a ($n=0$) ^a for I/Q points	yes
WAVEform - (time domain) (all modes)	RFENvelope ($n=2$) ^a (also for Signal Envelope trace) IQ ($n=5$) ^a ($n=0$) ^a for I/Q points	yes

- a. The n number indicates the sub-opcode that corresponds to this trace. Detailed descriptions of the trace data can be found in the MEASure subsystem documentation by looking up the sub-opcode for the appropriate measurement.

Marker X Value

:CALCulate:<measurement>:MARKer [1] | 2 | 3 | 4 :X <param>

:CALCulate:<measurement>:MARKer [1] | 2 | 3 | 4 :X?

Position the designated marker on its assigned trace at the specified X value. The parameter value is in X-axis units (which is often frequency or time).

The marker must have already been assigned to a trace. Use **:CALCulate:<measurement>:MARKer [1] | 2 | 3 | 4 :TRACe** to assign a marker to a particular trace.

The query returns the current X value of the designated marker. The measurement must be completed before querying the marker.

Example: **CALC:SPEC:MARK2:X 1.2e6 Hz**

Range: For Phase Noise mode: Graph Start Offset and Stop

Offset frequencies.

Default Unit: Matches the units of the trace on which the marker is positioned

Remarks: The keyword for the current measurement must be specified in the command. (Some examples include: LPLot, ACP, WAVeform)

Front Panel

Access: **Marker, <active marker>, RPG**

Marker X Position

:CALCulate:<measurement>:MARKer [1] | 2 | 3 | 4:X:POSition <integer>

:CALCulate:<measurement>:MARKer [1] | 2 | 3 | 4:X:POSition?

Position the designated marker on its assigned trace at the specified X position. A trace is composed of a variable number of measurement points. This number changes depending on the current measurement conditions. The current number of points must be identified before using this command to place the marker at a specific location.

The marker must have already been assigned to a trace. Use **:CALCulate:<measurement>:MARKer [1] | 2 | 3 | 4:TRACe** to assign a marker to a particular trace.

The query returns the current X position for the designated marker. The measurement must be completed before querying the marker.

Example: **CALC:SPEC:MARK:X:POS 500**

Range: 0 to a maximum of (3 to 920,000)

Remarks: The keyword for the current measurement must be specified in the command. (Some examples include: SPECTrum, WAVeform)

Front Panel

Access: **Marker, <active marker>, RPG**

Marker Readout Y Value

:CALCulate:<measurement>:MARKer [1] | 2 | 3 | 4:Y?

Readout the current Y value for the designated marker on its assigned trace. The value is in the Y-axis units for the trace (which is often dBm).

The marker must have already been assigned to a trace. Use **:CALCulate:<measurement>:MARKer [1] | 2 | 3 | 4:TRACe** to assign a marker to a particular trace.

Programming Commands
CALCulate Subsystem

The measurement must be completed before querying the marker.

Example: `CALC:SPEC:MARK1:Y?`

Default Unit: Matches the units of the trace on which the marker is positioned

Remarks: The keyword for the current measurement must be specified in the command. (Some examples include: LPLot, ACP, WAVeform)

CONFigure Subsystem

The CONFigure commands are used with several other commands to control the measurement process. The full set of commands are described in the section “[MEASure Group of Commands](#)” on page 213.

Selecting measurements with the CONFigure/FETCh/MEASure/READ commands sets the instrument state to the defaults for that measurement and to make a single measurement. Other commands are available for each measurement to allow you to change: settings, view, limits, etc. Refer to:

```
SENSe:<measurement>, SENSE:CHANnel, SENSE:CORRection,
SENSe:DEFaults, SENSE:DEViation, SENSE:FREQuency,
SENSe:PACKet, SENSE:POWer, SENSE:RADio, SENSE:SYNC
CALCulate:<measurement>, CALCulate:CLIMits
DISPlay:<measurement>
TRIGger
```

The INITiate[:IMMediate] or INITiate:REStart commands will initiate the taking of measurement data without resetting any of the measurement settings that you have changed from their defaults.

Configure the Selected Measurement

```
:CONFigure:<measurement>
```

A CONFigure command must specify the desired measurement. It will set the instrument settings for that measurement’s standard defaults, but should not initiate the taking of data. The available measurements are described in the MEASure subsystem.

NOTE

If CONFigure initiates the taking of data, the data should be ignored. Other SCPI commands can be processed immediately after sending CONFigure. You do not need to wait for the CONF command to complete this 'false' data acquisition.

Configure Query

```
:CONFigure?
```

The CONFigure query returns the name of the current measurement.

DISPlay Subsystem

The DISPlay controls the selection and presentation of textual, graphical, and TRACe information. Within a DISPlay, information may be separated into individual WINDows.

Adjacent Channel Power - View Selection

```
:DISPlay:ACP:VIEW BGRaph|SPECTrum
```

```
:DISPlay:ACP:VIEW?
```

Select the adjacent channel power measurement display of bar graph or spectrum.

You may want to disable the spectrum trace data part of the measurement so you can increase the speed of the rest of the measurement display. Use SENSE:ACP:SPECTrum:ENABLE to turn on or off the spectrum trace. (Basic and cdmaOne modes only)

Factory Preset: Bar Graph (BGRaph)

Remarks: For E4406A you must be in the Basic, cdmaOne, cdma2000, W-CDMA, NADC or PDC mode to use this command. Use INSTRument:SElect to set the mode.

For PSA you must be in the cdmaOne, cdma2000, W-CDMA, NADC or PDC mode to use this command. Use INSTRument:SElect to set the mode.

Front Panel

Access: **ACP, View/Trace**

Select Display Format

```
:DISPlay:FORMat:TILE
```

Selects the viewing format that displays multiple windows of the current measurement data simultaneously. Use DISP:FORM:ZOOM to return the display to a single window.

Remarks: For PSA you must be in the Basic, cdmaOne, cdma2000, 1xEV-DO, W-CDMA, GSM (w/EDGE), NADC, or PDC mode to use this command. Use INSTRument:SElect to set the mode

Front Panel

Access: **Zoom** (toggles between Tile and Zoom)

Select Display Format

:DISPlay:FORMat:ZOOM

Selects the viewing format that displays only one window of the current measurement data (the current active window). Use DISP:FORM:TILE to return the display to multiple windows.

Remarks: For PSA you must be in the Basic, cdmaOne,cdma2000, 1xEV-DO, W-CDMA, GSM (w/EDGE), NADC, or PDC mode to use this command. Use INSTRument:SElect to set the mode

Front Panel

Access: **Zoom** (toggles between Tile and Zoom)

Spectrum - Y-Axis Scale/Div

**:DISPlay:SPECTrum[n]:WINDow[m]:TRACe:Y[:SCALE]:PDIVision
 <power>**

:DISPlay:SPECTrum[n]:WINDow[m]:TRACe:Y[:SCALE]:PDIVision?

Sets the amplitude reference level for the y-axis.

n – selects the view, the default is Spectrum.

m – selects the window within the view. The default is 1.

— n=1, m=1 Spectrum

— n=1, m=2 I/Q Waveform

— n=1, m=2 I and Q Waveform (Basic, W-CDMA, cdma2000)

— n=1, m=3 numeric data (Service mode, E4406A only)

— n=1, m=4 RF envelope (Service mode, E4406A only)

— n=2, m=1 I Waveform (Option B7C, E4406A only)

— n=2, m=2 Q Waveform (Option B7C, E4406A only)

— n=3, m=1 I/Q Polar (Basic, W-CDMA, cdma2000)

— n=4, m=1 Linear Spectrum (Basic, W-CDMA, cdma2000)

Factory Preset: 10 dB per division, for Spectrum

100 mV per division, for I/Q Waveform

Range: 0.1 dB to 20 dB per division, for Spectrum

1 nV to 20 V per division, for I/Q Waveform

Default Unit: 10 dB per division, for Spectrum

Remarks: May affect input attenuator setting.

For E4406A to use this command, the appropriate mode should be selected with INSTRUMENT:SElect.

For PSA you must be in Basic, cdmaOne, cdma2000, 1xEV-DO, W-CDMA GSM w/EDGE, NADC, or PDC mode. Set the mode with INSTRUMENT:SElect.

Front Panel

Access: When in Spectrum measurement: **Amplitude Y Scale, Scale/Div.**

History: For PSA:
Added revision A.02.00

For E4406A:
Modified revision A.05.00

Spectrum - Y-Axis Reference Level

```
:DISPlay:SPECTrum[n]:WINDow[m]:TRACe:Y[:SCALe]:RLEVel  
<power>
```

```
:DISPlay:SPECTrum[n]:WINDow[m]:TRACe:Y[:SCALe]:RLEVel?
```

Sets the amplitude reference level for the y-axis.

n, selects the view, the default is RF envelope.

- n=1, m=1 Spectrum
- n=1, m=2 I/Q Waveform
- n=1, m=2 I and Q Waveform (Basic, W-CDMA, cdma2000)
- n=1, m=3 numeric data (Service mode, E4406A only)
- n=1, m=4 RF envelope (Service mode, E4406A only)
- n=2, m=1 I Waveform (Option B7C, E4406A only)
- n=2, m=2 Q Waveform (Option B7C, E4406A only)
- n=3, m=1 I/Q Polar (Basic, W-CDMA, cdma2000)
- n=4, m=1 Linear Spectrum (Basic, W-CDMA, cdma2000)

m – selects the window within the view. The default is 1.

Factory Preset: 0 dBm, for Spectrum

Range: – 250 to 250 dBm, for Spectrum

Default Unit: dBm, for Spectrum

Remarks: May affect input attenuator setting.

For E4406A to use this command, the appropriate mode should be selected with INSTRument:SElect.

For PSA you must be in Basic, cdmaOne, cdma2000, 1xEV-DO, W-CDMA GSM w/EDGE, NADC, or PDC mode. Set the mode with INSTRument:SElect.

Front Panel
 Access: When in Spectrum measurement: **Amplitude Y Scale, Ref Level**

History: For PSA:
 Added revision A.02.00

For E4406A:
 Modified revision A.05.00

Turn a Trace Display On/Off

```
:DISPlay:TRACe [n] [:STATe] OFF|ON|0|1
:DISPlay:TRACe [n] [:STATe] ?
```

Controls whether the specified trace is visible or not.

n is a sub-opcode that is valid for the current measurement. See the “[MEASure Group of Commands](#)” on page 213 for more information about sub-opcodes.

Factory Preset: On

Range: The valid traces and their sub-opcodes are dependent upon the selected measurement. See the following table.

The trace name assignment is independent of the window number.

Remarks: For E4406A to use this command, the appropriate mode should be selected with INSTRument:SElect.

Remarks: For PSA you must be in the Basic, cdmaOne,cdma2000, 1xEV-DO, W-CDMA, GSM (w/EDGE), NADC, or PDC mode to use this command. Use INSTRument:SElect to set the mode

Front Panel

Access: **Display, Display Traces**

Measurement	Available Traces	Markers Available?
ACP - adjacent channel power (Basic, cdmaOne, cdma2000, W-CDMA, iDEN (E4406A only), NADC, PDC modes)	no traces ($n=0$) ^a for I/Q points	no markers
BER - bit error rate (iDEN mode, E4406A only)	no traces ($n=0$) ^a for I/Q data	no markers
CDPower - code domain power (cdmaOne mode)	POWer ($n=2$) ^a TIMing ($n=3$) ^a PHASe ($n=4$) ^a ($n=0$) ^a for I/Q points	yes
CDPower - code domain power (cdma2000, 1xEV-DO, W-CDMA modes)	($n=0$) ^a for I/Q raw data CDPower ($n=2$) ^a EVM ($n=5$) ^a MERRor ($n=6$) ^a PERRor ($n=7$) ^a SPOWer ($n=9$) ^a CPOWer ($n=10$) ^a	yes
CHPower - channel power (Basic, cdmaOne, cdma2000, 1xEV-DO, W-CDMA modes)	SPECtrum ($n=2$) ^a ($n=0$) ^a for I/Q raw data	no markers
CSPur - spurs close (cdmaOne mode)	SPECtrum ($n=2$) ^a ULIMit ($n=3$) ^a ($n=0$) ^a for I/Q points	yes
EEVM - EDGE error vector magnitude (EDGE mode)	EVMerror ($n=2$) ^a MERRor ($n=3$) ^a PERRor ($n=4$) ^a ($n=0$) ^a for I/Q points	yes

Measurement	Available Traces	Markers Available?
EORFspectr - EDGE output RF spectrum (EDGE mode)	RFEMod ($n=2$) ^a RFESwitching ($n=3$) ^a SPEMod ($n=4$) ^a LIMMod ($n=5$) ^a ($n=0$) ^a for I/Q points	yes, only for a single offset yes, only for multiple offsets
EPVTime - EDGE power versus time (EDGE mode)	RFENvelope ($n=2$) ^a UMASk ($n=3$) ^a LMASk ($n=4$) ^a ($n=0$) ^a for I/Q points	yes
ETSPur - EDGE transmit band spurs (EDGE mode)	SPECTrum ($n=2$) ^a ULIMit ($n=3$) ^a ($n=0$) ^a for I/Q points	yes
EVM - error vector magnitude (NADC, PDC modes)	EVM ($n=2$) ^a MERRor ($n=3$) ^a PERRor ($n=4$) ^a ($n=0$) ^a for I/Q points	yes
EVMQpsk - QPSK error vector magnitude (cdma2000, 1xEV-DO, W-CDMA modes)	EVM ($n=2$) ^a MERRor ($n=3$) ^a PERRor ($n=4$) ^a ($n=0$) ^a for I/Q raw data	yes
IM - intermodulation (cdma2000, 1xEV-DO, W-CDMA modes)	SPECTrum ($n=2$) ^a ($n=0$) ^a for I/Q raw data	yes
MCPower - multi-carrier power (W-CDMA mode)	no traces ($n=0$) ^a for I/Q points	no markers
OBW - occupied bandwidth (cdmaOne, cdma2000, 1xEV-DO, iDEN (E4406A only), PDC, W-CDMA modes)	no traces ($n=0$) ^a for I/Q raw data	no markers

Measurement	Available Traces	Markers Available?
ORFSpectrum - output RF spectrum (GSM, EDGE mode)	RFEMod ($n=2$) ^a RFESwitching ($n=3$) ^a SPEMod ($n=4$) ^a LIMMod ($n=5$) ^a ($n=0$) ^a for I/Q points	yes, only for a single offset yes, only for multiple offsets
PFERror - phase and frequency error (GSM, EDGE mode)	PERRor ($n=2$) ^a PFERror ($n=3$) ^a RFENvelope ($n=4$) ^a ($n=0$) ^a for I/Q points	yes
PStatistic - power statistics CCDF (Basic, cdma2000, 1xEV-DO, W-CDMA modes)	MEASured ($n=2$) ^a GAUSian ($n=3$) ^a REFerence ($n=4$) ^a ($n=0$) ^a for I/Q points	yes
PVTime - power versus time (GSM, EDGE, 1xEV-DO, Service (E4406A only) modes)	($n=0$) ^a for I/Q raw data RFENvelope ($n=2$) ^a UMASk ($n=3$) ^a LMASk ($n=4$) ^a	yes
RHO - modulation quality (cdmaOne, cdma2000, W-CDMA mode)	($n=0$) ^a for I/Q raw data EVM ($n=2$) ^a MERRor ($n=3$) ^a PERRor ($n=4$) ^a ($n=5$) ^a for I/Q corrected trace data	yes

Measurement	Available Traces	Markers Available?
RHO - modulation quality (1xEV-DO mode)	(n=0) ^a for I/Q raw data (n=1) ^a for various summary results EVM (n=2) ^a MERRor (n=3) ^a PERRor (n=4) ^a (n=5) ^a for I/Q corrected trace data	yes
SEMask - spectrum emissions mask (cdma2000, 1xEV-DO, W-CDMA mode)	SPECTrum (n=2) ^a (n=0) ^a for I/Q raw data	yes
TSPur - transmit band spurs (GSM, EDGE mode)	SPECTrum (n=2) ^a ULIMit (n=3) ^a (n=0) ^a for I/Q points	yes
TXPower - transmit power (GSM, EDGE mode)	RFENvelope (n=2) ^a IQ (n=8) ^a (n=0) ^a for I/Q points	yes
SPECTrum - (frequency domain) (all modes)	RFENvelope (n=2) ^a for Service mode (E4406A only) IQ (n=3) ^a SPECTrum (n=4) ^a ASPectrum (n=7) ^a (n=0) ^a for I/Q raw data	yes
WAVEform - (time domain) (all modes)	RFENvelope (n=2) ^a (also for Signal Envelope trace) IQ (n=5) ^a (n=0) ^a for I/Q raw data	yes

- a. The n number indicates the sub-opcode that corresponds to this trace. Detailed descriptions of the trace data can be found in the MEASure subsystem documentation by looking up the sub-opcode for the appropriate measurement.

Waveform - Y-Axis Scale/Div

```
:DISPlay:WAVEform [n] :WINDow [m] :TRACe:Y[:SCALe] :PDIVision  
<power>
```

```
:DISPlay:WAVEform [n] :WINDow [m] :TRACe:Y[:SCALe] :PDIVision?
```

Sets the scale per division for the y-axis.

n , selects the view, the default is RF envelope.

$n=1$, $m=1$ RF envelope

$n=2$, $m=1$ I/Q Waveform

$n=2$, $m=1$ I and Q Waveform (Option B7C, E4406A only)

$n=4$, $m=1$ I/Q Polar (Basic, W-CDMA, cdma2000)

$n=5$, $m=1$ Linear Envelope (Option B7C, E4406A only)

m , selects the window within the view. The default is 1.

Factory Preset: 10 dBm, for RF envelope

Range: .1 dB to 20 dB, for RF envelope

Default Unit: dBm, for RF envelope

Remarks: May affect input attenuator setting.

For E4406A to use this command, the appropriate mode should be selected with INSTRument:SElect.

For PSA you must be in Basic, cdmaOne, cdma2000, 1xEV-DO, W-CDMA GSM w/EDGE, NADC, or PDC mode. Set the mode with INSTRument:SElect.

Front Panel

Access: When in Waveform measurement: **Amplitude Y Scale, Scale/Div.**

History: For PSA:
Added revision A.02.00

For E4406A:
Modified revision A.05.00

Waveform - Y-Axis Reference Level

```
:DISPlay:WAVEform [n] :WINDow [m] :TRACe:Y[:SCALE] :RLEVEL
<power>
```

```
:DISPlay:WAVEform [n] :WINDow [m] :TRACe:Y[:SCALE] :RLEVEL?
```

Sets the amplitude reference level for the y-axis.

n, selects the view, the default is RF envelope.

n=1, m=1 RF envelope

n=2, m=1 I/Q Waveform

n=2, m=1 I and Q Waveform (Option B7C, E4406A only)

n=4, m=1 I/Q Polar (Basic, W-CDMA, cdma2000)

n=5, m=1 Linear Envelope (Option B7C, E4406A only)

m, selects the window within the view. The default is 1.

Factory Preset: 0 dBm, for RF envelope

Range: - 250 to 250 dBm, for RF envelope

Default Unit: dBm, for RF envelope

Remarks: May affect input attenuator setting.

For E4406A to use this command, the appropriate mode should be selected with INSTRUMENT:SELEct.

For PSA you must be in Basic, cdmaOne, cdma2000, 1xEV-DO, W-CDMA GSM w/EDGE, NADC, or PDC mode. Set the mode with INSTRUMENT:SELEct.

Front Panel

Access: When in Waveform measurement: **Amplitude Y Scale, Ref Level**

History: For PSA:
 Added revision A.02.00

For E4406A:
 Modified revision A.05.00

FETCh Subsystem

The FETCh? queries are used with several other commands to control the measurement process. These commands are described in the section on the “[MEASure Group of Commands](#)” on [page 213](#). These commands apply only to measurements found in the MEASURE menu.

This command puts selected data from the most recent measurement into the output buffer (new data is initiated/measured). Use FETCh if you have already made a good measurement and you want to look at several types of data (different [n] values) from the single measurement. FETCh saves you the time of re-making the measurement. You can only fetch results from the measurement that is currently active.

If you need to make a new measurement, use the READ command, which is equivalent to an INITiate[:IMMEDIATE] followed by a FETCh.

:FETCh <meas>? will return valid data only when the measurement is in one of the following states:

- idle
- initiated
- paused

Fetch the Current Measurement Results

:FETCh: <measurement> [n] ?

A FETCh? command must specify the desired measurement. It will return the valid results that are currently available, but will not initiate the taking of any new data. You can only fetch results from the measurement that is currently selected. The code number n selects the kind of results that will be returned. The available measurements and data results are described in the “[MEASure Group of Commands](#)” on [page 213](#).

FORMat Subsystem

The FORMat subsystem sets a data format for transferring numeric and array information. For PSA the TRACe[:DATA] command is affected by FORMat subsystem commands.

Byte Order

:FORMat:BORDER NORMAl | SWAPped

:FORMat:BORDER?

Selects the binary data byte order for numeric data transfer. In normal mode the most significant byte is sent first. In swapped mode the least significant byte is first. (PCs use the swapped order.) Binary data byte order functionality does not apply to ASCII.

Factory Preset: Normal

Remarks: You must be in the Basic, cdma2000, 1xEV-DO, W-CDMA, GSM (w/EDGE), NADC, or PDC mode to use this command. Use INSTRument:SElect to set the mode.

Numeric Data Format

PSA/VSA Basic, cdmaOne, cdma2000, 1xEV-DO, W-CDMA, GSM, EDGE, NADC, PDC modes:

:FORMat[:DATA] ASCii | REAL, 32 | REAL, 64

:FORMat[:DATA]?

PSA Spectrum Analysis mode only:

:FORMat[:TRACe] [:DATA]

ASCii | INTeger, 16 | INTeger, 32 | REAL, 32 | REAL, 64 | UNINteger, 16

:FORMat[:TRACe] [:DATA]?

PSA Noise Figure mode only:

:FORMat[:TRACe] [:DATA] ASCii | REAL[, 32]

:FORMat[:TRACe] [:DATA]?

VSA/PSA application modes: This command controls the format of data input/output, that is any data transfer across any remote port. The REAL and ASCII formats will format data in the current display units. The format of state data cannot be changed. It is always in a machine

readable format only.

ASCII - Amplitude values are in ASCII, in amplitude units, separated by commas. ASCII format requires more memory than the binary formats. Therefore, handling large amounts of this type of data, will take more time and storage space.

Integer,16 - Binary 16-bit integer values in internal units (dBm), in a definite length block. **PSA, SA mode only.

Integer,32 - Binary 32-bit integer values in internal units (dBm), in a definite length block.

Real,32 or Real,64 - Binary 32-bit (or 64-bit) real values in amplitude unit, in a definite length block. Transfers of real data are done in a binary block format.

UINTeger,16 - Binary 16-bit unsigned integer that is uncorrected ADC values, in a definite length block. This format is almost never applicable with current measurement data.

A definite length block of data starts with an ASCII header that begins with # and indicates how many additional data points are following in the block. Suppose the header is #512320.

- The first digit in the header (5) tells you how many additional digits/bytes there are in the header.
- The 12320 means 12 thousand, 3 hundred, 20 data bytes follow the header.
- Divide this number of bytes by your selected data format bytes/point, either 8 (for real 64), or 4 (for real 32). In this example, if you are using real 64 then there are 1540 points in the block.

Example: FORM REAL,64

Factory Preset: ASCII

Real,32 for Spectrum Analysis mode

ASCII for Basic, cdmaOne, cdma2000, 1xEV-DO,
W-CDMA, GSM with EDGE, NADC, PDC modes

Remarks: The acceptable settings for this command change for the different modes as described above.

INITiate Subsystem

The INITiate subsystem is used to initiate a trigger for a measurement. They only initiate measurements from the MEASURE front panel key or the “MEASure Group of Commands” on page 213. Refer to the TRIGger and ABORt subsystems for related commands.

Take New Data Acquisition for Selected Measurement

:INITiate:<measurement>

For PSA this command is not available for measurements in the instrument modes: Spectrum Analysis, or Phase Noise.

This command initiates a trigger cycle for the measurement specified, but does not return data. The available measurement names are described in the MEASure subsystem..

If your selected measurement is not currently active it will change to the measurement in your INIT:<meas> command and initiate a trigger cycle.

Example: INIT:ACP

Continuous or Single Measurements

:INITiate:CONTinuous OFF|ON|0|1

:INITiate:CONTinuous?

Selects whether a trigger is continuously initiated or not. Each trigger initiates a single, complete, measurement operation.

When set to ON another trigger cycle is initiated at the completion of each measurement.

When set to OFF, the trigger system remains in the “idle” state until an INITiate[:IMMediate] command is received. On receiving the INITiate[:IMMediate] command, it will go through a single trigger/measurement cycle, and then return to the “idle” state.

Example: INIT:CONT ON

Factory Preset: On

*RST: Off (recommended for remote operation)

Front Panel

Access: **Meas Control, Measure Cont Single**

Take New Data Acquisitions

:INITiate[:IMMEDIATE]

The instrument must be in the single measurement mode. If INIT:CONT is ON, then the command is ignored. The desired measurement must be selected and waiting. The command causes the system to exit the “waiting” state and go to the “initiated” state.

The trigger system is initiated and completes one full trigger cycle. It returns to the “waiting” state on completion of the trigger cycle. Depending upon the measurement and the number of averages, there may be multiple data acquisitions, with multiple trigger events, for one full trigger cycle.

This command triggers the instrument, if external triggering is the type of trigger event selected. Otherwise, the command is ignored. Use the TRIGGER[:SEQUENCE]:SOURCE EXT command to select the external trigger.

Example: INIT:IMM

Remarks: See also the *TRG command and the TRIGGER subsystem.

Front Panel

Access: **Meas Control, Measure Cont Single**

Restart the Measurement

:INITiate:REStart

This command applies to measurements found in the MEASURE menu. It restarts the current measurement from the “idle” state regardless of its current operating state. It is equivalent to:

INITiate[:IMMEDIATE]

ABORT (for continuous measurement mode)

Example: INIT:REST

Front Panel

Access: **Restart**

or

Meas Control, Restart

INSTRUMENT Subsystem

This subsystem includes commands for querying and selecting instrument measurement (personality option) modes.

Catalog Query

For E4406A, `:INSTRUMENT:CATALOG[:FULL]?`

For PSA, `:INSTRUMENT:CATALOG?`

Returns a comma separated list of strings which contains the names of all the installed applications. These names can only be used with the `INST:SELECT` command.

For E4406A if the optional keyword `FULL` is specified, each name is immediately followed by its associated instrument number. These instrument numbers can only be used with the `INST:NSELECT` command.

Example:

(PSA) `INST:CAT?`

Query response: "CDMA"4,"PNOISE"14

Example:

(E4406A) `INST:CAT:FULL?`

Query response:
 "BASIC"8,"GSM"3,"CDMA"4,"SERVICE"1

Select Application by Number

`:INSTRUMENT:NSELECT <integer>`

`:INSTRUMENT:NSELECT?`

Select the measurement mode by its instrument number. The actual available choices depends upon which applications are installed in the instrument. For E4406A these instrument numbers can be obtained with `INST:CATALOG:FULL?`

- 1 = SA (PSA)
- 1 = SERVICE (E4406)
- 3 = GSM (E4406)
- 4 = CDMA (cdmaOne) (E4406/PSA)
- 5 = NADC (E4406/PSA)
- 6 = PDC (E4406/PSA)
- 8 = BASIC (E4406/PSA)
- 9 = WCDMA (W-CDMA with HSDPA/HSUPA) (E4406/PSA)

- 10 = CDMA2K (cdma2000 with 1xEV-DV) (E4406/PSA)
- 11 = IDEN (E4406)
- 12 = WIDEN (E4406)
- 13 = EDGE GSM (E4406/PSA)
- 14 = PNOISE (phase noise) (PSA)
- 15 = CMDA1XEV (1xEV-D0) (E4406/PSA)
- 18 = WLAN (PSA)
- 211 = TDSCDMA (PSA)
- 212 = TDDEMOD (PSA)
- 219 = NFIGURE (noise figure) (PSA)
- 231 = LINK (89600 VSA Link software)
- 233 = MRECEIVE (PSA)
- 239 = EMC (EMC Analyzer) (PSA)
- 241 = DMODULATION (PSA)

NOTE

If you are using the SCPI status registers and the analyzer mode is changed, the status bits should be read, and any errors resolved, prior to switching modes. Error conditions that exist prior to switching modes cannot be detected using the condition registers after the mode change. This is true unless they recur after the mode change, although transitions of these conditions can be detected using the event registers.

Changing modes resets all SCPI status registers and mask registers to their power-on defaults. Hence, any event or condition register masks must be re-established after a mode change. Also note that the power up status bit is set by any mode change, since that is the default state after power up.

Example: INST:NSEL 4

Factory Preset: Persistent state with factory default of 1 (PSA)

Persistent state with factory default of 8
(E4406A, BASIC)

Range: 1 to x, where x depends upon which applications are installed.

Front Panel

Access: **MODE**

Select Application

VSA E4406A:

```
:INSTrument[:SElect]  
BASIC|SERVICE|CDMA|CDMA2K|GSM|EDGE GSM|IDEN|  
WIDEN|NADC|PDC|WCDMA|CDMA1XEV
```

PSA Series:

```
:INSTRument [:SElect]  

SA | PNOISE | BASIC | CDMA | CDMA2K | EDGEgSM | NADC | PDC |  

WCDMA | CDMA1xEV | NFIGURE | WLAN | TDSCDMA | TDDEMOD |  

MRECEIVE | EMC | DEMODULATION
```

```
:INSTRument [:SElect] ?
```

Select the measurement mode. The actual available choices depend upon which modes (measurement applications) are installed in the instrument. A list of the valid choices is returned with the INST:CAT? query.

Once an instrument mode is selected, only the commands that are valid for that mode can be executed.

- 1 = SA (PSA)
- 1 = SERVICE (E4406)
- 3 = GSM (E4406)
- 4 = CDMA (cdmaOne) (E4406/PSA)
- 5 = NADC (E4406/PSA)
- 6 = PDC (E4406/PSA)
- 8 = BASIC (E4406/PSA)
- 9 = WCDMA (W-CDMA with HSDPA/HSUPA) (E4406/PSA)
- 10 = CDMA2K (cdma2000 with 1xEV-DV) (E4406/PSA)
- 11 = IDEN (E4406)
- 12 = WIDEN (E4406)
- 13 = EDGEgSM (E4406/PSA)
- 14 = PNOISE (phase noise) (PSA)
- 15 = CMDA1XEV (1xEV-D0) (E4406/PSA)
- 18 = WLAN (PSA)
- 211 = TDSCDMA (PSA)
- 212 = TDDEMOD (PSA)
- 219 = NFIGURE (noise figure) (PSA)
- 231 = LINK (89600 VSA Link software)
- 233 = MRECEIVE (PSA)
- 239 = EMC (EMC Analyzer) (PSA)
- 241 = DMODULATION (PSA)

NOTE

If you are using the status bits and the analyzer mode is changed, the status bits should be read, and any errors resolved, prior to switching modes. Error conditions that exist prior to switching modes cannot be detected using the condition registers after the mode change. This is true unless they recur after the mode change, although transitions of these conditions can be detected using the event registers.

Changing modes resets all SCPI status registers and mask registers to their power-on defaults. Hence, any event or condition register masks must be re-established after a mode change. Also note that the power up status bit is set by any mode change, since that is the default state after power up.

Programming Commands
INSTRUMENT Subsystem

Example: PSA Series instruments: INST:SEL CDMA

Factory Preset:
(PSA) Persistent state with factory default of Spectrum Analyzer mode

Factory Preset:
(E4406A) Persistent state with factory default of Basic mode.

Front Panel
Access: **MODE**

MEASure Group of Commands

This group includes the CONFigure, FETCh, MEASure, and READ commands that are used to make measurements and return results. The different commands can be used to provide fine control of the overall measurement process, like changing measurement parameters from their default settings. Most measurements should be done in single measurement mode, rather than measuring continuously.

The SCPI default for the format of any data output is ASCII. The format can be changed to binary with FORMat:DATA which transports faster over the bus.

Command Interactions: MEASure, CONFigure, FETCh, INITiate and READ

Each one-button measurement has a group of commands that work together to make the measurement fast, but flexible.

Figure 1 Measurement Group of Commands

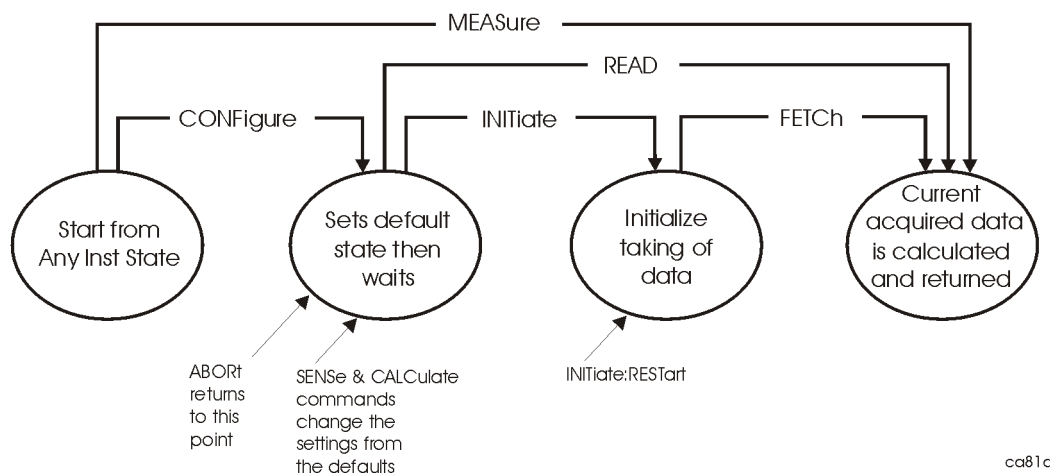

Measure Commands:

:MEASure:<measurement> [n] ?

This is a fast single-command way to make a measurement using the factory default instrument settings. These are the settings and units that conform to the Mode Setup settings (e.g. radio standard) that you have currently selected.

- Stops the current measurement (if any) and sets up the instrument for the specified measurement using the factory defaults
- Initiates the data acquisition for the measurement
- Blocks other SCPI communication, waiting until the measurement is complete before returning results.
- If the function does averaging, it is turned on and the number of averages is set to 10.
- After the data is valid it returns the scalar results, or the trace data, for the specified measurement. The type of data returned may be defined by an [n] value that is sent with the command.

The scalar measurement results will be returned if the optional [n] value is not included, or is set to 1. If the [n] value is set to a value other than 1, the selected trace data results will be returned. See each command for details of what types of scalar results or trace data results are available.

ASCII is the default format for the data output. (Older versions of Spectrum Analysis and Phase Noise mode measurements only use ASCII.) The binary data formats should be used for handling large blocks of data since they are smaller and faster than the ASCII format. Refer to the FORMat:DATA command for more information.

If you need to change some of the measurement parameters from the factory default settings you can set up the measurement with the CONFigure command. Use the commands in the SENSE:<measurement> and CALCulate:<measurement> subsystems to change the settings. Then you can use the READ? command to initiate the measurement and query the results. See [Figure 1](#).

If you need to repeatedly make a given measurement with settings other than the factory defaults, you can use the commands in the SENSE:<measurement> and CALCulate:<measurement> subsystems to set up the measurement. Then use the READ? command to initiate the measurement and query results.

Measurement settings persist if you initiate a different measurement and then return to a previous one. Use READ:<measurement>? if you want to use those persistent settings. If you want to go back to the default settings, use MEASure:<measurement>?.

Configure Commands:

:CONFigure:<measurement>

This command stops the current measurement (if any) and sets up the instrument for the specified measurement using the factory default instrument settings. It sets the instrument to single measurement mode but should not initiate the taking of measurement data unless INIT:CONTinuous is ON. If you change any measurement settings after using the CONFigure command, the READ command can be used to initiate a measurement without changing the settings back to their defaults. In Spectrum Analysis mode the CONFigure command also turns the averaging function on and sets the number of averages to 10 for all measurements.

In instruments with firmware older than A.05.00 CONFigure initiates the taking of data. This data should be ignored. Other SCPI commands can be processed immediately after sending CONFigure. You do not need to wait for the CONF command to complete this initial 'false' data acquisition.

The CONFigure? query returns the current measurement name.

Fetch Commands:

:FETCh:<measurement> [n] ?

This command puts selected data from the most recent measurement into the output buffer. Use FETCh if you have already made a good measurement and you want to return several types of data (different [n] values, e.g. both scalars and trace data) from a single measurement. FETCh saves you the time of re-making the measurement. You can only FETCh results from the measurement that is currently active, it will not change to a different measurement.

If you need to get new measurement data, use the READ command, which is equivalent to an INITiate followed by a FETCh.

The scalar measurement results will be returned if the optional [n] value is not included, or is set to 1. If the [n] value is set to a value other than 1, the selected trace data results will be returned. See each command for details of what types of scalar results or trace data results are available. The binary data formats should be used for handling large blocks of data since they are smaller and transfer faster than the ASCII format. (FORMat:DATA)

FETCh may be used to return results other than those specified with the original READ or MEASure command that you sent.

INITiate Commands:

:INITiate:<measurement>

This command is not available for measurements in all the instrument modes:

- Initiates a trigger cycle for the specified measurement, but does not output any data. You must then use the **FETCh<meas>** command to return data. If a measurement other than the current one is specified, the instrument will switch to that measurement and then initiate it.
For example, suppose you have previously initiated the ACP measurement, but now you are running the channel power measurement. If you send **INIT:ACP?** it will change from channel power to ACP and will initiate an ACP measurement.
- Does not change any of the measurement settings. For example, if you have previously started the ACP measurement and you send **INIT:ACP?** it will initiate a new ACP measurement using the same instrument settings as the last time ACP was run.
- If your selected measurement is currently active (in the idle state) it triggers the measurement, assuming the trigger conditions are met. Then it completes one trigger cycle. Depending upon the measurement and the number of averages, there may be multiple data acquisitions, with multiple trigger events, for one full trigger cycle. It also holds off additional commands on GPIB until the acquisition is complete.

READ Commands:

:READ:<measurement> [n] ?

- Does not preset the measurement to the factory default settings. For example, if you have previously initiated the ACP measurement and you send **READ:ACP?** it will initiate a new measurement using the same instrument settings.
- Initiates the measurement and puts valid data into the output buffer. If a measurement other than the current one is specified, the instrument will switch to that measurement before it initiates the measurement and returns results.

For example, suppose you have previously initiated the ACP measurement, but now you are running the channel power measurement. Then you send **READ:ACP?** It will change from channel power back to ACP and, using the previous ACP settings, will initiate the measurement and return results.

- Blocks other SCPI communication, waiting until the measurement is complete before returning the results

If the optional [n] value is not included, or is set to 1, the scalar measurement results will be returned. If the [n] value is set to a value other than 1, the selected trace data results will be returned. See each command for details of what types of scalar results or trace data results are available. The binary data formats should be used when handling large blocks of data since they are smaller and faster than the ASCII format. (**FORMat:DATA**)

Current Measurement Query (Remote Command Only)

This command returns the name of the measurement that is currently running.

**Remote
Command:**

:CONFigure?

Example: CONF?

Test Current Results Against all Limits (Remote Command Only)

Queries the status of the current measurement limit testing. It returns a 0 if the measured results pass when compared with the current limits. It returns a 1 if the measured results fail any limit tests.

**Remote
Command:**

:CALCulate:CLIMits:FAIL?

Example: CALC:CLIM:FAIL?

Adjacent Channel Power Ratio (ACP) Measurement

For E4406A this measures the total rms power in the specified channel and in 5 offset channels. You must be in Basic, cdmaOne, cdma2000, W-CDMA, iDEN, NADC or PDC mode to use these commands. Use INSTRument:SElect to set the mode.

For PSA this measures the total rms power in the specified channel and in 5 offset channels. You must be in cdmaOne, cdma2000, W-CDMA, NADC or PDC mode to use these commands. Use INSTRument:SElect to set the mode.

The general functionality of CONFigure, FETCh, MEASure, and READ are described at the beginning of this section. See the SENSE:ACP commands for more measurement related commands.

```
:CONFigure:ACP
:INITiate:ACP
:FETCh:ACP [n] ?
:READ:ACP [n] ?
:MEASure:ACP [n] ?
```

For Basic mode, a channel frequency and power level can be defined in the command statement to override the default standard setting. A comma must precede the power value as a place holder for the frequency, when no frequency is sent.

History: E4406A:
 Added to Basic mode, version A.03.00 or later

Front Panel

Access: **Measure, ACP or ACPR**

After the measurement is selected, press **Restore Meas Defaults** to restore factory defaults.

Measurement Results Available

Measurement Type	n	Results Returned
	0	Returns unprocessed I/Q trace data, as a series of trace point values, in volts. The I values are listed first in each pair, using the 0 through even-indexed values. The Q values are the odd-indexed values.

Measurement Type	n	Results Returned
	n=1 (or not specified) NADC and PDC mode	Returns 22 scalar results, in the following order: 1. Center frequency – absolute power (dBm) 2. Center frequency – absolute power (W) 3. Negative offset frequency (1) – relative power (dB) 4. Negative offset frequency (1) – absolute power (dBm) 5. Positive offset frequency (1) – relative power (dB) 6. Positive offset frequency (1) – absolute power (dBm) . . . 1. Positive offset frequency (5) – relative power (dB) 2. Positive offset frequency (5) – absolute power (dBm)
	n=1 (or not specified) iDEN mode E4406A	Returns 13 scalar results, in the following order: 1. Center frequency – relative power (dB) 2. Center frequency – absolute power (dBm) 3. Lower offset frequency – relative power (dB) 4. Lower offset freq– absolute power (dBm) 5. Upper offset frequency – relative power (dB) 6. Upper offset frequency – absolute power (dBm) 7. Total power (dBm) 8. Offset frequency (Hz) 9. Reference BW (Hz) 10. Offset BW (Hz) 11. Carrier/center frequency (Hz) 12. Frequency span (Hz) 13. Average count
Total power reference	n=1 (or not specified) Basic, cdmaOne, cdma2000, W-CDMA mode	Returns 24 scalar results, in the following order: 1. Center frequency - relative power (dB) 2. Center frequency - absolute power (dBm) 3. Center frequency - relative power (dB) (same as value 1) 4. Center frequency - absolute power (dBm) (same as value 2) 5. Negative offset frequency (1) - relative power (dB), 6. Negative offset frequency (1) - absolute power (dBm) 7. Positive offset frequency (1) - relative power (dB) 8. Positive offset frequency (1) - absolute power (dBm) . . . 1. Positive offset frequency (5) - relative power (dB) 2. Positive offset frequency (5) - absolute power (dBm) _____ NOTE Center frequency relative power is relative to the center frequency absolute power and therefore, is always equal to 0.00 dB. _____

Measurement Type	n	Results Returned
Power spectral density reference	n=1 (or not specified) Basic, cdmaOne, cdma2000, W-CDMA mode	<p>Returns 24 scalar results, in the following order:</p> <ol style="list-style-type: none"> 1. Center frequency - relative power (dB) 2. Center frequency - absolute power (dBm/Hz) 3. Center frequency - relative power (dB) (same as value 1) 4. Center frequency - absolute power (dBm/Hz) (same as value 2) 5. Negative offset frequency (1) - relative power (dB) 6. Negative offset frequency (1) - absolute power (dBm/Hz) 7. Positive offset frequency (1) - relative power (dB) 8. Positive offset frequency (1) - absolute power (dBm/Hz) <p style="text-align: center;">. . .</p> <ol style="list-style-type: none"> 1. Positive offset frequency (5) - relative power (dB) 2. Positive offset frequency (5) - absolute power (dBm/Hz) <hr/> <p>NOTE Center frequency relative power is relative to the center frequency absolute power and therefore, is always equal to 0.00 dB.</p>
	2 NADC and PDC mode	<p>Returns 10 scalar values of the pass/fail (0=passed, or 1=failed) results determined by testing the absolute power of the offset frequencies:</p> <ol style="list-style-type: none"> 1. Negative offset frequency (1) absolute power 2. Positive offset frequency (1) absolute power <p style="text-align: center;">. . .</p> <ol style="list-style-type: none"> 1. Negative offset frequency (5) absolute power 2. Positive offset frequency (5) absolute power
	2 iDEN mode	<p>Returns 3 scalar values of the histogram absolute power trace:</p> <ol style="list-style-type: none"> 1. Lower offset frequency – absolute power 2. Reference frequency – absolute power 3. Upper offset frequency – absolute power

Measurement Type	n	Results Returned
Total power reference	2 Basic, cdmaOne, cdma2000, W-CDMA mode	Returns 11 scalar values (in dBm) corresponding to the total power histogram display. The values are returned in ascending frequency order: 1. Negative offset frequency (5) 2. Negative offset frequency (4) 3. Negative offset frequency (3) . . . 1. Center frequency 2. Positive offset frequency (1) 3. Positive offset frequency (2) . . . 1. Positive offset frequency (5)
	3 NADC and PDC mode	Returns 10 scalar values of the pass/fail (0=passed, or 1=failed) results determined by testing the relative power of the offset frequencies: 1. Negative offset frequency (1) relative power 2. Positive offset frequency (1) relative power . . . 1. Negative offset frequency (5) relative power 2. Positive offset frequency (5) relative power
	3 iDEN mode E4406A	Returns 3 scalar values of the histogram relative power trace: 1. Lower offset frequency – relative power 2. Reference frequency – relative power 3. Upper offset frequency – relative power
Power spectral density reference	3 Basic, cdmaOne, cdma2000, W-CDMA mode	Returns 11 scalar values (in dBm/Hz) corresponding to the power spectral density histogram display. The values are returned in ascending frequency order: 1. Negative offset frequency (5) 2. Negative offset frequency (4) . . . 1. Center frequency 2. Positive offset frequency (1) . . . 1. Positive offset frequency (5)

Measurement Type	n	Results Returned
	4 NADC and PDC mode	Returns the frequency-domain spectrum trace (data array) for the entire frequency range being measured. In order to return spectrum data, the ACP display must be in the spectrum view and you must not turn off the spectrum trace.
	4 iDEN mode E4406A	Returns 4 absolute power values for the reference and offset channels. <ol style="list-style-type: none"> 1. Reference channel – absolute power 2. Reference channel – absolute power (duplicate of above) 3. Lower offset channel – absolute power 4. Upper offset channel – absolute power
(For cdma2000 and W-CDMA the data is only available with spectrum display selected)	4 Basic, cdmaOne, cdma2000, W-CDMA mode	Returns the frequency-domain spectrum trace data for the entire frequency range being measured. With the spectrum view selected (DISPlay:ACP:VIEW SPECTrum) and the spectrum trace on (SENSe:ACP:SPECTrum:ENABLE): <ul style="list-style-type: none"> • In FFT mode (SENSe:ACP:SWEep:TYPE FFT) the number of trace points returned are 343 (cdma2000) or 1715 (W-CDMA). This is with the default span of 5 MHz (cdma2000) or 25 MHz (W-CDMA). The number of points also varies if another offset frequency is set. • In sweep mode (SENSe:ACP:SWEep:TYPE SWEep), the number of trace points returned is 601 (for cdma2000 or W-CDMA) for any span. With bar graph display selected, one point of –999.0 will be returned.
	5 iDEN mode E4406A	Returns 4 relative power values for the reference and offset channels: <ol style="list-style-type: none"> 1. Reference channel – relative power 2. Reference channel – relative power (duplicate of above) 3. Lower offset channel – relative power 4. Upper offset channel – relative power
Total power reference	5 Basic, cdmaOne, cdma2000, W-CDMA mode	Returns 12 scalar values (in dBm) of the absolute power of the center and the offset frequencies: <ol style="list-style-type: none"> 1. Upper adjacent chan center frequency 2. Lower adjacent chan center frequency 3. Negative offset frequency (1) 4. Positive offset frequency (1) <p style="text-align: center;">. . .</p> <ol style="list-style-type: none"> 1. Negative offset frequency (5) 2. Positive offset frequency (5)

Measurement Type	n	Results Returned
Power spectral density reference	5 Basic, cdmaOne, cdma2000, W-CDMA mode	Returns 12 scalar values (in dBm/Hz) of the absolute power of the center and the offset frequencies: <ol style="list-style-type: none"> 1. Upper adjacent chan center frequency 2. Lower adjacent chan center frequency 3. Negative offset frequency (1) 4. Positive offset frequency (1) <p style="text-align: center;">. . .</p> <ol style="list-style-type: none"> 1. Negative offset frequency (5) 2. Positive offset frequency (5)
	6 iDEN mode E4406A	Returns 4 pass/fail test results for the absolute power of the reference and offset channels: <ol style="list-style-type: none"> 1. Reference channel absolute power pass/fail 2. Reference channel absolute power pass/fail (duplicate of above) 3. Lower offset channel absolute power pass/fail 4. Upper offset channel absolute power pass/fail
Total power reference	6 Basic, cdmaOne, cdma2000, W-CDMA mode	Returns 12 scalar values (total power in dB) of the power relative to the carrier at the center and the offset frequencies: <ol style="list-style-type: none"> 1. Upper adjacent chan center frequency 2. Lower adjacent chan center frequency 3. Negative offset frequency (1) 4. Positive offset frequency (1) 5. Negative offset frequency (5) <p style="text-align: center;">. . .</p> <ol style="list-style-type: none"> 1. Negative offset frequency (5) 2. Positive offset frequency (5)
Power spectral density reference	6 Basic, cdmaOne, cdma2000, W-CDMA mode	Returns 12 scalar values (power spectral density in dB) of the power relative to the carrier at the center and offset frequencies: <ol style="list-style-type: none"> 1. Upper adjacent chan center frequency 2. Lower adjacent chan center frequency 3. Negative offset frequency (1) 4. Positive offset frequency (1) <p style="text-align: center;">. . .</p> <ol style="list-style-type: none"> 1. Negative offset frequency (5) 2. Positive offset frequency (5)

Measurement Type	n	Results Returned
	7 iDEN mode E4406A	Returns 4 pass/fail test results for the relative power of the reference and offset channels: 1. Reference channel relative power pass/fail 2. Reference channel relative power pass/fail (duplicate of above) 3. Lower offset channel relative power pass/fail 4. Upper offset channel relative power pass/fail
Total power reference	7 Basic, cdmaOne, cdma2000, W-CDMA mode	Returns 12 scalar values of the pass/fail (0=passed, or 1=failed) results determined by testing the absolute power limit of the center and offset frequencies (measured as total power in dB): 1. Upper adjacent chan center frequency 2. Lower adjacent chan center frequency 3. Negative offset frequency (1) 4. Positive offset frequency (1) . . . 1. Negative offset frequency (5) 2. Positive offset frequency (5)
Power spectral density reference	7 Basic, cdmaOne, cdma2000, W-CDMA mode	Returns 12 scalar values of the pass/fail (0=passed, or 1=failed) results determined by testing the absolute power limit of the center and offset frequencies (measured as power spectral density in dB): 1. Upper adjacent chan center frequency 2. Lower adjacent chan center frequency 3. Negative offset frequency (1) 4. Positive offset frequency (1) . . . 1. Negative offset frequency (5) 2. Positive offset frequency (5)
Total power reference	8 Basic, cdmaOne, cdma2000, W-CDMA mode	Returns 12 scalar values of the pass/fail (0=passed, or 1=failed) results determined by testing the power limit relative to the center frequency (measured as total power spectral in dB): 1. Upper adjacent chan center frequency 2. Lower adjacent chan center frequency 3. Negative offset frequency (1) 4. Positive offset frequency (1) . . . 1. Negative offset frequency (5) 2. Positive offset frequency (5)

Measurement Type	n	Results Returned
Power spectral density reference	8 Basic, cdmaOne, cdma2000, W-CDMA mode	<p>Returns 12 scalar values of the pass/fail (0=passed, or 1=failed) results determined by testing the power limit relative to the center frequency (measured as power spectral density in dB):</p> <ol style="list-style-type: none"> 1. Upper adjacent chan center frequency 2. Lower adjacent chan center frequency 3. Negative offset frequency (1) 4. Positive offset frequency (1) <p style="text-align: center;">. . .</p> <ol style="list-style-type: none"> 1. Negative offset frequency (5) 2. Positive offset frequency (5)

Code Domain Power Measurement

This measures the power levels of the spread channels in RF channel(s). You must be in the cdmaOne, cdma2000, W-CDMA, or 1xEV-DO mode to use these commands. Use INSTRument:SElect to set the mode.

For 1xEV-DO, this measurement is used only for base stations (Network Access). When measuring 1xEV-DO mobile stations (Access Terminals) use Terminal Code Domain Measurements (MEAS:TCDPower) and set SENSE:RADio:DEvice to MS.

The general functionality of CONFigure, FETCh, MEASure, and READ are described at the beginning of this section. See the SENSE:CDPower commands for more measurement related commands.

```
:CONFigure:CDPower
:INITiate:CDPower
:FETCh:CDPower [n] ?
:READ:CDPower [n] ?
:MEASure:CDPower [n] ?
```

Front Panel

Access: **Measure, Code Domain**

After the measurement is selected, press **Restore Meas Defaults** to restore factory defaults.

Measurement Results Available

n	Results Returned
0	Returns unprocessed I/Q trace data, as a series of trace point values, in volts. The I values are listed first in each pair, using the 0 through even-indexed values. The Q values are the odd-indexed values.

n	Results Returned
<p>n=1 (or not specified) cdmaOne mode</p>	<p>Returns the following 25 scalar results:</p> <ol style="list-style-type: none"> 1. Time offset is a floating point number with units of seconds. This is the time delay of the even second clock with respect to the start of the short code PN sequences, at offsets from the 15 zeros in the characteristic phase of the sequences. 2. Frequency error is a floating point number (in Hz) of the frequency error in the measured signal. This error is based on the linear best fit of the uncorrected measured phase. 3. Carrier feedthrough is a floating point number (in dB) of the dc offset, of I and Q, from the origin. 4. Pilot power is a floating point number with units of dB. It is the relative power of the pilot channel (Walsh code 0) with respect to the carrier power. 5. Paging power is a floating point number with units of dB. It is the relative power of the paging channel (Walsh code 1) with respect to the carrier power. 6. Sync power is a floating point number with units of dB. It is the relative power of the sync channel (Walsh code 32) with respect to the carrier power. 7. Average traffic power is a floating point number with units of dB. It is the average relative power of the active traffic channels with respect to the carrier power. Traffic channels are defined as all of the Walsh codes except Walsh 0,1,32. A traffic channel is active if its coding power is greater than the active threshold parameter which you have selected. 8. Maximum inactive traffic power is a floating point number with units of dB. It is the maximum relative power of an inactive traffic channel with respect to the carrier power. Traffic channels are defined as all of the Walsh codes except Walsh 0,1,32. A traffic channel is inactive if its coding power is less than the active threshold parameter which you have selected. 9. Average inactive traffic power is a floating point number with units of dB. It is the average relative power of the inactive traffic channels with respect to the carrier power. Traffic channels are defined as all of the Walsh codes except Walsh 0,1,32. A traffic channel is inactive if its coding power is less than the active threshold parameter which you have selected. 10. Marker Values The last 16 measurement results are the current values for all four available markers. The values are zero for any marker that is not active. <ol style="list-style-type: none"> 10. Marker 1 position (code number) 11, Marker 1 power level 12. Marker 1 time value 13. Marker 1 phase value . . . 25. Marker 4 phase value

n	Results Returned
n=1 (or not specified) cdma2000 mode	<p>Returns the following 19 scalar results:</p> <ol style="list-style-type: none"> 1. RMS symbol EVM is a floating point number (in percent) of the EVM over the entire measurement area. 2. Peak symbol EVM is a floating point number (in percent) of the peak EVM in the measurement area. 3. Symbol magnitude error is a floating point number (in percent) of the average magnitude error over the entire measurement area. 4. Symbol phase error is a floating point number (in degrees) of the average phase error over the entire measurement area. 5. Total power is a floating point number (in dBm) of the total RF power over the measurement interval. 6. Average power is a floating point number (in dBm) of the power in the entire slot, for the selected code, averaged over the measurement interval. 7. Total active power is a floating point number (in dB or dBm depending on the measurement type) of the sum of the active power. 8. Pilot power is a floating point number (in dB or dBm depending on the measurement type) of the average power of the Pilot code. 9. Sync power is a floating point number (in dB or dBm depending on the measurement type) of the average power of the Sync code. In the MS mode, the value returned is – 999. 10. Maximum active traffic power is a floating point number (in dB or dBm depending on the measurement type) of the maximum average power of the active code. If no active code is detected the value returned is – 999. In the MS mode, the value returned is – 999. 11. Average active traffic power is a floating point number (in dB or dBm depending on the measurement type) of the average power of all the active traffic channels. If no active code is detected the value returned is – 999. In the MS mode, the value returned is – 999. 12. Maximum inactive traffic power is a floating point number (in dB or dBm depending on the measurement type) of the maximum average power of the inactive traffic channels. In the MS mode, the value returned is – 999. 13. Average inactive traffic power is a floating point number (in dB or dBm depending on the measurement type) of the average power of the inactive traffic channels. In the MS mode, the value returned is – 999. 14. Number of active channel In the MS mode, the value returned is – 999.

n	Results Returned
n=1 (or not specified) cdma2000 mode (continued)	<ol style="list-style-type: none"> <li data-bbox="467 289 1399 380">1. I channel average active power is a floating point number (in dB or dBm depending on the measurement type) of the average power of the active I channels. In the BS mode, the value returned is – 999. <li data-bbox="467 401 1399 520">2. I channel maximum inactive power is a floating point number (in dB or dBm depending on the measurement type) of the maximum average power of the inactive I channels. In the BS mode, the value returned is – 999. <li data-bbox="467 541 1399 632">3. Q channel average active power is a floating point number (in dB or dBm depending on the measurement type) of the average power of the active Q channels. In the BS mode, the value returned is – 999. <li data-bbox="467 653 1399 772">4. Q channel maximum inactive power is a floating point number (in dB or dBm depending on the measurement type) of the maximum average power of the inactive Q channels. In the BS mode, the value returned is – 999. <li data-bbox="467 793 1399 884">5. Time between trigger to PN Off set is a floating point number (in μs) of the time from the trigger point to the PN Offset. In the MS mode, the value returned is – 999.

n	Results Returned
n=1 (or not specified) W-CDMA mode	<p>Returns the following 31 scalar results:</p> <ol style="list-style-type: none"> 1. RMS symbol EVM is a floating point number (in percent) of the EVM over the entire measurement area. 2. Peak symbol EVM is a floating point number (in percent) of the peak EVM in the measurement area. 3. Symbol magnitude error is a floating point number (in percent) of the average magnitude error over the entire measurement area. 4. Symbol phase error is a floating point number (in degrees) of the average phase error over the entire measurement area. 5. Total power is a floating point number (in dBm) of the total RF power over the measurement interval. 6. Average power is a floating point number (in dBm) of the power in the entire slot, for the selected code, averaged over the measurement interval. 7. tDPCH is a floating point number (in 256 chips) of dedicated physical channel (DPCH) delay time from the reference. (tDPCH equals T_n) 8. Total power over a slot is a floating point number (in dBm) of total RF power over the measurement interval. (SCH is excluded.) 9. Total active power is a floating point number (in dB or dBm depending on the measurement type) of the sum of the active power. (SCH is excluded.) 10. Pilot power is a floating point number (in dB or dBm depending on the measurement type) of the average power of the CPICH code relative to the total slot power. In the MS mode, the value returned is – 999. (SCH is excluded.) 11. Maximum active traffic power is a floating point number (in dB or dBm depending on the measurement type) of the maximum average power of the active traffic channels. If no active code is detected the value returned is – 999. In the MS mode, the value returned is – 999. (SCH is excluded.) 12. Average active traffic power is a floating point number (in dB or dBm depending on the measurement type) of the average power of all the active traffic channels. If no active code is detected the value returned is – 999. In the MS mode, the value returned is – 999. (SCH is excluded.) 13. Maximum inactive traffic power is a floating point number (in dB or dBm depending on the measurement type) of the maximum average power of the inactive traffic channels. The slot timing is determined by Perch. In the MS mode, the value returned is – 999. (SCH is excluded.) 14. Average inactive traffic power is a floating point number (in dB or dBm depending on the measurement type) of the average power of the inactive traffic channels. In the MS mode, the value returned is – 999. (SCH is excluded.) 15. Number of active channel In the MS mode, the value returned is – 999.

n	Results Returned
<p>n=1 (or not specified) W-CDMA mode (continued)</p>	<p>16. P-SCH is a floating point number (in dBm) of the primary synchronization channel power. In the MS mode, the value returned is – 999.</p> <p>17. S-SCH is a floating point number (in dBm) of the secondary synchronization channel power. In the MS mode, the value returned is – 999.</p> <p>18. DPCCH Power is a floating point number (in dB or dBm depending on the measurement type) of the average power of dedicated physical control channel (DPCCH). In the BS mode, the value returned is – 999. When PRACH is measured, this returns control part power.</p> <p>19. DPCCH Beta Nominal is a floating point number of the nominal beta value of DPCCH Beta factor. In the BS mode, the value returned is – 999. When PRACH is measured, this returns control part Beta nominal.</p> <p>20. DPCCH Beta Measured is a floating point number of the measured value of the DPCCH Beta factor. In the BS mode, the value returned is – 999. When PRACH is measured, this returns control part Beta measured.</p> <p>21. DPDCH Beta Nominal is a floating point number of the nominal beta value of the dedicated physical data channel (DPDCH) Beta factor. In the BS mode, the value returned is – 999. When PRACH is measured, this returns control part Beta nominal.</p> <p>22. DPDCH Beta 1 Measured is a floating point number of the measured value of the DPDCH (C1) Beta factor. In the BS mode, the value returned is – 999. When PRACH is measured, this returns control part Beta measured.</p> <p>23. DPDCH Beta 2 Measured is a floating point number of the measured value of the DPDCH (C2) Beta factor. In the BS mode, the value returned is – 999. When PRACH is measured, this returns – 999.</p> <p>24. DPDCH Beta 3 Measured is a floating point number of the measured value of the DPDCH (C3) Beta factor. In the BS mode, the value returned is – 999. When PRACH is measured, this returns – 999.</p> <p>25. DPDCH Beta 4 Measured is a floating point number of the measured value of the DPDCH (C4) Beta factor. In the BS mode, the value returned is – 999. When PRACH is measured, this returns – 999.</p> <p>26. DPDCH Beta 5 Measured is a floating point number of the measured value of the DPDCH (C5) Beta factor. In the BS mode, the value returned is – 999. When PRACH is measured, this returns – 999.</p> <p>27. DPDCH Beta 6 Measured is a floating point number of the measured value of the DPDCH (C6) Beta factor. In the BS mode, the value returned is – 999. When PRACH is measured, this returns – 999.</p>

n	Results Returned
<p>n=1 (or not specified) W-CDMA mode (continued)</p>	<p>28. I channel average active power is a floating point number (in dB or dBm depending on the measurement type) of the average power of the active I channels. In the BS mode, the value returned is – 999.</p> <p>29. I channel maximum inactive power is a floating point number (in dB or dBm depending on the measurement type) of the maximum average power of the inactive I channels. In the BS mode, the value returned is – 999.</p> <p>30. Q channel average active power is a floating point number (in dB or dBm depending on the measurement type) of the average power of the active Q channels. In the BS mode, the value returned is – 999.</p> <p>31. Q channel maximum inactive power is a floating point number (in dB or dBm depending on the measurement type) of the maximum average power of the inactive Q channels. In the BS mode, the value returned is – 999.</p>

n	Results Returned
<p>n=1 (or not specified)</p> <p>1xEV-DO mode</p>	<p>Returns the following 18 comma-delimited scalar results, in the following order:</p> <ol style="list-style-type: none"> 1. Total power is a floating point number (in dBm) of the total RF power over the measurement interval. <p>NOTE: The following power results are computed by the CDP measurement. The unit used in the computation, either dB or dBm, is determined by the setting of the CALCulate:CDPower:TYPE command. When the selection is ABSolute, the unit used is dBm. When the selection is RELative, the unit used is dB relative to Total Power (above).</p> <ol style="list-style-type: none"> 2. Total active power is a floating point number (in dB or dBm depending on the measurement type) of the sum of the active powers (– 999 when no active channel is detected). 3. Maximum active power is a floating point number (in dB or dBm depending on the measurement type) of the maximum average power of the active code (– 999 when no active channel is detected in I/Q Combined=On mode. Always – 999 in I/Q Combined=Off mode) 4. Average active power is a floating point number (in dB or dBm depending on the measurement type) of the average power of all the active traffic channels (– 999 when no active channel is detected in I/Q Combined=On mode. Always – 999 in I/Q Combined=Off mode). 5. Maximum inactive power is a floating point number (in dB or dBm depending on the measurement type) of the maximum average power of the inactive traffic channels. (– 999 in I/Q Combined=Off mode) 6. Average inactive power is a floating point number (in dB or dBm depending on the measurement type) of the average power of the inactive traffic channels. (– 999 in I/Q Combined=Off mode) 7. Number of active channels 8. I channel average active power is a floating point number (in dB or dBm depending on the measurement type) of the average power of the active I channels. (– 999 when I/Q Combined=On mode or when no active channel is detected in I/Q Combined=Off mode). 9. I channel maximum inactive power is a floating point number (in dB or dBm depending on the measurement type) of the maximum average power of the inactive I channels. (– 999 when I/Q Combined=On mode) 10. Q channel average active power is a floating point number (in dB or dBm depending on the measurement type) of the average power of the active Q channels. (– 999 when I/Q Combined=On mode or when no active channel is detected in I/Q Combined=Off mode). 11. Q channel maximum inactive power is a floating point number (in dB or dBm depending on the measurement type) of the maximum average power of the inactive Q channels. (– 999 when I/Q Combined=On mode)

n	Results Returned
n=1 (or not specified) 1xEV-DO mode (continued)	12. Preamble Length is a floating point number (in chips). 13. Preamble MAC Index is an integer number of MAC index. 14. Minimum Active Power is a floating point number (in dB or dBm depending on the measurement type) of the minimum average power of the active code (–.999.0 when no active channel is detected in I/Q Combined=On mode. Always –.999.0 in I/Q Combined=Off mode) 15. I channel maximum inactive power is a floating point number (in dB or dBm depending on the measurement type) of the maximum average power of the inactive I channels. (–.999.0 when I/Q Combined=On mode) 16. I channel minimum inactive power is a floating point number (in dB or dBm depending on the measurement type) of the minimum average power of the inactive I channels. (–.999.0 when I/Q Combined=On mode) 17. Q channel maximum inactive power is a floating point number (in dB or dBm depending on the measurement type) of the maximum average power of the inactive Q channels. (–.999.0 when I/Q Combined=On mode) 18. Q channel minimum inactive power is a floating point number (in dB or dBm depending on the measurement type) of the minimum average power of the inactive Q channels. (–.999.0 when I/Q Combined=On mode)
2 cdmaOne mode	Returns floating point numbers that are the trace data of the code domain <i>power</i> trace for all 64 Walsh codes. This series of 64 numbers represent the relative power levels (in dB) of all 64 walsh codes, with respect to the carrier power.

n	Results Returned
2 cdma2000 mode	<p>Returns a series of floating point numbers (in dB or dBm depending on the measurement type) that represents all the code domain powers.</p> <p>With a device of BTS, there are 64 or 128 numbers depending on CALCulate:CDPower:WCODE:BASE. If the active channel occupies more than the max spreading factor (64 or 128 Walsh Code length depending on CALCulate:CDPower:WCODE:BASE) the power is duplicated (CALCulate:CDPower:WCODE:BASE / active Walsh code length) times.</p> <p>1st number = 1st code power over the slot 2nd number = 2nd code power over the slot ... Nth number = Nth code power over the slot</p> <p>With a device of MS, there are 256 I/Q pairs. If the active channel occupies more than the max spreading factor (C8) the power is duplicated (active Cx / C8) times.</p> <p>1st number = 1st in-phase code power over the slot 2nd number = 1st quad-phase code power over the slot ... (2×N-1)th number = Nth in-phase code power over the slot (2×N)th number = Nth quad-phase code power over a slot</p> <p>N = the number of codes detected. The total number of codes varies because of the different symbol rates of each code.</p>
2 1xEV-DO mode	<p>Returns a series of floating point numbers (in dB or dBm depending on the measurement type) that represents all the code domain powers.</p> <p>When I/Q Combined=On, total is 16 for Data, 32 for Pilot, and 64 for MAC. If the active channel occupies more than the max spreading factor (16 for Data, 32 for Pilot, and 64 for MAC) the power is duplicated.</p> <p>1st number = 1st code power over the slot 2nd number = 2nd code power over the slot ... Nth number = Nth code power over the slot</p> <p>When I/Q Combined=Off, results are returned alternatively. Total is 16 I/Q pairs for Data, 32 for Pilot, and 64 for MAC. If the active channel occupies more than the max spreading factor (16 for Data, 32 for Pilot, and 64 for MAC) the power is duplicated.</p> <p>1st number = 1st in-phase code power over the slot 2nd number = 1st quad-phase code power over the slot ... (2×N-1)th number = Nth in-phase code power over the slot (2×N)th number = Nth quad-phase code power over a slot</p> <p>N = the number of codes detected. The total number of codes varies because of the different symbol rates of each code.</p>

n	Results Returned
<p>2 W-CDMA.mode</p>	<p>Returns a series of floating point numbers (in dB or dBm depending on the measurement type) that represents all the code domain powers.</p> <p>With a device of BTS, there are 512 numbers. If the active channel occupies more than the max spreading factor (7.5 ksps) the power is duplicated (active symbol rate/7.5 ksps) times.</p> <p style="padding-left: 40px;">1st number = 1st code power over the slot 2nd number = 2nd code power over the slot ... Nth number = Nth code power over the slot</p> <p>With a device of MS, there are 256 I/Q pairs. If the active channel occupies more than the max spreading factor (15 ksps) the power is duplicated (active symbol rate / 15 ksps) times.</p> <p style="padding-left: 40px;">1st number = 1st in-phase code power over the slot 2nd number = 1st quad-phase code power over the slot ... (2×N-1)th number = Nth in-phase code power over the slot (2×N)th number = Nth quad-phase code power over a slot</p> <p>N = the number of codes detected. The total number of codes varies because of the different symbol rates of each code.</p>
<p>3 cdmaOne mode</p>	<p>Returns floating point numbers that are the trace data of the code domain <i>timing</i> trace for all 64 Walsh codes. This series of 64 numbers represent the relative timing estimations (in seconds) of the codes, relative to the pilot channel. Typical values are on the order of 1 ns.</p>

n	Results Returned
3 cdma2000 mode	<p>Returns a series of floating point numbers (in symbol rate) that represent all code domain symbol rates.</p> <p>With a device of BTS, there are 64 or 128 numbers depending on CALCulate:CDPower:WCODE:BASE. If the active channel occupies more than the max spreading factor (64 or 128 Walsh code length depending on CALCulate:CDPower:WCODE:BASE) the power is duplicated (CALCulate:CDPower:WCODE:BASE / active Walsh code length) times.</p> <p>1st number = 1st code symbol rate over the slot 2nd number = 2nd code symbol rate over the slot ... Nth number = Nth code symbol rate over the slot</p> <p>With a device of MS, there are 256 I/Q pairs. If the active channel occupies more than the max spreading factor (C8) the power is duplicated (active Cx / C8) times.</p> <p>1st number = 1st in-phase code symbol rate over the slot 2nd number = 1st quad-phase code symbol rate over the slot ... (2×N-1)th number = Nth in-phase code symbol rate over the slot (2×N)th number = Nth quad-phase code symbol rate over the slot</p> <p>N = the number of codes detected. The total number of codes varies because of the different symbol rates of each code.</p>
3 1xEV-DO mode	<p>Returns a series of floating point numbers (in dB or dBm depending on the measurement type) that represents all the code domain symbol rates.</p> <p>When I/Q Combined=On, total is 16 for Data, 32 for Pilot, and 64 for MAC. If the active channel occupies more than the max spreading factor (16 for Data, 32 for Pilot, and 64 for MAC) the power is duplicated.</p> <p>1st number = 1st code symbol rate over the slot 2nd number = 2nd code symbol rate over the slot ... Nth number = Nth code symbol rate over the slot</p> <p>When I/Q Combined=Off, results are returned alternatively. Total is 16 I/Q pairs for Data, 32 for Pilot, and 64 for MAC. If the active channel occupies more than the max spreading factor (16 for Data, 32 for Pilot, and 64 for MAC) the power is duplicated.</p> <p>1st number = 1st in-phase code symbol rate over the slot 2nd number = 1st quad-phase code symbol rate over the slot ... (2×N-1)th number = Nth in-phase code symbol rate over the slot (2×N)th number = Nth quad-phase code symbol rate over a slot</p> <p>N = the number of codes detected. The total number of codes varies because of the different symbol rates of each code.</p>

n	Results Returned
3 W-CDMA mode	<p>Returns a series of floating point numbers (in symbol rate) that represent all code domain symbol rates.</p> <p>With a device of BTS, there are 512 numbers. If the active channel occupies more than the max spreading factor (7.5 ksp/s) the power is duplicated (active symbol rate/7.5 ksp/s) times.</p> <p>1st number = 1st code symbol rate over the slot 2nd number = 2nd code symbol rate over the slot ... Nth number = Nth code symbol rate over the slot</p> <p>With a device of MS, there are 256 I/Q pairs. If the active channel occupies more than the max spreading factor (15 ksp/s) the power is duplicated (active symbol rate/15 ksp/s) times.</p> <p>1st number = 1st in-phase code symbol rate over the slot 2nd number = 1st quad-phase code symbol rate over the slot ... (2×N-1)th number = Nth in-phase code symbol rate over the slot (2×N)th number = Nth quad-phase code symbol rate over the slot</p> <p>N = the number of codes detected. The total number of codes varies because of the different symbol rates of each code.</p>
4 cdmaOne mode	<p>Returns floating point numbers that are the trace data of the code domain <i>phase</i> trace for all 64 Walsh codes. This series of 64 numbers represent the relative phase estimations (in radians) of the codes, relative to the pilot channel. Typical values are on the order of 1 mrad.</p>
4 cdma2000 or W-CDMA mode	<p>Returns a series of floating point numbers that show either active or inactive status for each of the code powers returned in n=2. (See above.) If a code is inactive, the value returned is 0.0, otherwise a value >0.0 is returned.</p> <p>1st number = active or inactive flag of the 1st code ... Nth number = active or inactive flag of the Nth code</p> <p>(where N= the number of codes identified)</p>

n	Results Returned
4 1xEV-DO mode	<p>Returns a series of floating point numbers that show either active or inactive status for each of the code powers returned in n=2 and 3. If a code is inactive, the value returned is 0.0, otherwise a value >0.0 is returned.</p> <p>When I/Q Combined=On, I/Q combined results are returned. 1st number = active or inactive flag of the 1st code ... Nth number = active or inactive flag of the Nth code</p> <p>When channel type=Pilot or MAC, results are returned alternatively. 1st number = 1st in-phase code active flag 2nd number = 1st Quad Phase code active flag ... (2×N-1)th number = Nth in-phase code active flag (2×N)th number = Nth Quad Phase code active flag</p> <p>N = the number of codes detected. The total number of codes varies because of the different symbol rates of each code. 2nd number = 1st quad-phase code symbol rate over the slot</p>
5 cdma2000, or W-CDMA mode	<p>Returns a series of floating point numbers (in percent) that represent each sample in the <i>EVM</i> trace. The first number is the symbol 0 decision point and there are X points per symbol. Therefore, the decision points are at 0, 1×X, 2×X, 3×X. . .</p> <p>(where X = the number of points per chip)</p>
5 1xEV-DO mode	<p>Returns series of floating point numbers that alternately represent I and Q pairs of the <i>corrected measured</i> trace. The magnitude of each I and Q pair is normalized to 1.0. The first number is the in-phase (I) sample of symbol 0 decision point and the second is the quadrature-phase (Q) sample of symbol 0 decision point. As in the EVM, there are X points per symbol, so that:</p> <p>1st number is I of the symbol 0 decision point 2nd number is Q of the symbol 0 decision point ... (2×X)+1 number is I of the symbol 1 decision point (2×X)+2 number is Q of the symbol 1 decision point ... (2×X)×N+1th number is I of the symbol N decision point (2×X)×N+2th number is Q of the symbol N decision point</p> <p>where X = the number of points per symbol, and N = the number of symbols</p>
6 cdma2000, or W-CDMA mode	<p>Returns a series of floating point numbers (in percent) that represent each sample in the <i>magnitude error</i> trace. The first number is the symbol 0 decision point and there are X points per symbol. Therefore, the decision points are at 0, 1×X, 2×X, 3×X. . .</p> <p>(where X = the number of points per chip)</p>

n	Results Returned
6 1xEV-DO mode	Returns series of floating point numbers (in dBm) that represent the trace data of the chip power vs. time.
7 cdma2000, or W-CDMA mode	Returns a series of floating point numbers (in degrees) that represent each sample in the <i>phase error</i> trace. The first number is the symbol 0 decision point and there are X points per symbol. Therefore, the decision points are at 0, 1×X, 2×X, 3×X. . . (where X = the number of points per chip)
8 cdma2000, or W-CDMA mode	Returns series of floating point numbers that alternately represent I and Q pairs of the <i>corrected measured</i> trace. The magnitude of each I and Q pair is normalized to 1.0. The first number is the in-phase (I) sample of symbol 0 decision point and the second is the quadrature-phase (Q) sample of symbol 0 decision point. As in the EVM, there are X points per symbol, so that: 1st number is I of the symbol 0 decision point 2nd number is Q of the symbol 0 decision point ... (2×X)+1 number is I of the symbol 1 decision point (2×X)+2 number is Q of the symbol 1 decision point ... (2×X)×N+1th number is I of the symbol N decision point (2×X)×N+2th number is Q of the symbol N decision point where X = the number of points per symbol, and N = the number of symbols
9 cdma2000, or W-CDMA mode	Returns series of floating point numbers (in dBm) that represent the trace data of the symbol power vs. time.
10 cdma2000, or W-CDMA mode	Returns series of floating point numbers (in dBm) that represent the trace data of the chip power vs. time.
11 cdma2000	Returns a series of floating point numbers (0.0 or 1.0) of the symbol values (demodulated bits) for the selected spread code. The results are returned as alternating values of I,Q,I,Q . . . for the entire measurement interval.
11 W-CDMA mode	Returns series of floating point numbers (0.0 or 1.0) of symbol values for the selected code with the entire capture length, when :CALCulate:CDPower:DBITs[:FORMat] is set to BINary. Returns series of floating point numbers (0.0, 1.0 or -1.0) of symbol values for the selected code with the entire capture length, when :CALCulate:CDPower:DBITs[:FORMat] is set to TRIState. “-1.0” represents DTX (Discontinuous Transmission) bit.

n	Results Returned
12 W-CDMA mode	Returns series of floating point numbers (0.0 or 1.0) of symbol values for the selected code with the period selected by Meas Interval, and Meas Offset and tDPCH, when :CALCulate:CDPower:DBITs[:FORMat] is set to BINary. Returns series of floating point numbers (0.0, 1.0 or -1.0) of symbol values for the selected code with the period selected by Meas Interval, and Meas Offset and tDPCH, when :CALCulate:CDPower:DBITs[:FORMat] is set to TRIState. “-1.0” represents DTX (Discontinuous Transmission) bit.

Channel Power Measurement

For E4406A this measures the total rms power in a specified integration bandwidth. You must be in the Basic, cdmaOne, cdma2000, W-CDMA, or 1xEV-DO mode to use these commands. Use INSTRument:SElect to set the mode.

For PSA this measures the total rms power in a specified integration bandwidth. You must be in the cdmaOne, cdma2000, or W-CDMA, or 1xEV-DO mode to use these commands. Use INSTRument:SElect to set the mode.

The general functionality of CONFigure, FETCh, MEASure, and READ are described at the beginning of this section. See the SENSE:CHPower commands for more measurement related commands.

```
:CONFigure:CHPower
:INITiate:CHPower
:FETCh:CHPower [n] ?
:READ:CHPower [n] ?
:MEASure:CHPower [n] ?
```

History: For E4406A:
 Added to Basic mode, version A.03.00 or later

Front Panel

Access: **Measure, Channel Power**

After the measurement is selected, press **Restore Meas Defaults** to restore factory defaults.

Measurement Results Available

n	Results Returned
0	Returns unprocessed I/Q trace data, as a series of trace point values, in volts. The I values are listed first in each pair, using the 0 through even-indexed values. The Q values are the odd-indexed values.
n=1 (or not specified)	Returns 2 scalar results: <ol style="list-style-type: none"> Channel Power is a floating point number representing the total channel power in the specified integration bandwidth. PSD (Power Spectral Density) is the power (in dBm/Hz) in the specified integration bandwidth.
2	Returns floating point numbers that are the captured trace data of the power (in dBm/resolution BW) of the signal. The frequency span of the captured trace data is specified by the Span key.

Spur Close Measurement

This measures the spurious emissions in the transmit band relative to the channel power in the selected channel. You must be in the cdmaOne mode to use these commands. Use INSTRument:SElect to set the mode.

The general functionality of CONFigure, FETCh, MEASure, and READ are described at the beginning of this section. See the SENSE:CSPur commands for more measurement related commands.

```
:CONFigure:CSPur
:INITiate:CSPur
:FETCh:CSPur [n] ?
:READ:CSPur [n] ?
:MEASure:CSPur [n] ?
```

Front Panel

Access: **Measure, Spur Close**

After the measurement is selected, press **Restore Meas Defaults** to restore factory defaults.

Measurement Results Available

n	Results Returned
0	Returns unprocessed I/Q trace data, as a series of trace point values, in volts. The I values are listed first in each pair, using the 0 through even-indexed values. The Q values are the odd-indexed values.
n=1 (or not specified)	Returns 3 scalar results: <ol style="list-style-type: none"> 1. The worst spur's frequency difference from channel center frequency (in MHz) 2. The worst spur's amplitude difference from the limit (in dB) 3. The worst spur's amplitude difference from channel power (in dB)
2	Returns trace of the segment containing the worst spur.

Modulation Accuracy (Rho) Measurement

This measures the modulation accuracy of the transmitter by checking the magnitude and phase error and the EVM (error vector magnitude). You must be in the cdmaOne, cdma2000, W-CDMA, or 1xEV-DO mode to use these commands. Use INSTRument:SElect to set the mode.

For 1xEV-DO: these commands will measure modulation accuracy on network access equipment (base transmitter stations). Use MEAS:TRHO to measure terminal transmitter modulation accuracy, after selecting mobile stations using SENSE:RADio:DEvice MS.

The general functionality of CONFigure, FETCh, MEASure, and READ are described at the beginning of this section. See the SENSE:RHO commands for more measurement related commands.

```
:CONFigure:RHO
:INITiate:RHO
:FETCh:RHO [n] ?
:READ:RHO [n] ?
:MEASure:RHO [n] ?
```

Front Panel

Access: **Measure, Mod Accuracy (Rho)** for cdmaOne

Measure, Mod Accuracy (Composite Rho) for cdma2000, 1xEV-DO, or W-CDMA (3GPP)

After the measurement is selected, press **Restore Meas Defaults** to restore factory defaults.

Measurement Results Available

n	Results Returned
0 cdmaOne mode	Returns unprocessed I/Q trace data, as a series of trace point values. The I values are listed first in each pair, using the 0 through even-indexed values. The Q values are the odd-indexed values. The standard sample rate is 7.5 MHz and the trace length is determined by the current measurement interval.
0 cdma2000 or W-CDMA mode	Returns unprocessed I/Q trace data, as a series of trace point values. The I values are listed first in each pair, using the 0 through even-indexed values. The Q values are the odd-indexed values.

n	Results Returned
n=1 (or not specified) cdmaOne mode	<p>Returns 7 floating point numbers, in the following order:</p> <ol style="list-style-type: none"> 1. Rho (no units) represents the correlation of the measured power compared to the ideal pilot channel. The calculation is performed after the complimentary filter, so it is IS95 compliant. It is performed at the decision points in the pilot waveform. If averaging is on, this is the average of the individual rms measurements. 2. Time offset (with units of seconds) is the time delay of the even second clock with respect to the start of the short code PN sequences, at offsets from the 15 zeros in the characteristic phase of the sequence. 3. Frequency error of the measured signal, with units of Hz. This is based on the linear best fit of the uncorrected measured phase. 4. Carrier feedthrough has units of dB and is the dc error offset of I and Q, from the origin. 5. EVM has units of percent. The calculation is based on the composite of the phase error and magnitude error, between the measured signal and the ideal pilot channel. It is performed after the complimentary filter which removes the inter-symbol interference in the modulated data. If averaging is on, this is the average of the individual rms measurements. 6. Magnitude error (with units of percent) is the rms error between the measured (compensated) magnitude and the ideal magnitude. This is performed after the complimentary filter which removes the inter-symbol interference in the modulated data. If averaging is on, this is the average of the individual rms measurements. 7. Phase error (with units in percent) is the rms phase error between the measured phase and the ideal phase. The calculation is performed after the complimentary filter which removes the inter-symbol interference in the modulated data. If averaging is on, this is the average of the individual rms measurements.

n	Results Returned
n=1 (or not specified) cdma2000	<p>Returns 11 scalar results, in the following order.</p> <ol style="list-style-type: none"> 1. RMS EVM is a floating point number (in percent) of EVM over the entire measurement area 2. Peak EVM is a floating point number (in percent) of peak EVM in the measurement area 3. Magnitude error is a floating point number (in percent) of average magnitude error over the entire measurement area 4. Phase error is a floating point number (in degree) of average phase error over the entire measurement area 5. I/Q origin offset is a floating point number (in dB) of the I and Q error (magnitude squared) offset from the origin 6. Frequency error is a floating point number (in Hz) of the frequency error in the measured signal 7. Rho is a floating point number of Rho 8. Peak code domain error is a floating point number (in dB) of the Peak Code Domain Error relative to the mean power 9. Peak code domain error channel number is the channel number in which the peak code domain error is detected at the max spreading factor. 10. Number of active channels. 11. Time offset is a floating point number (in second) PN offset from the trigger point.

n	Results Returned
<p>n=1 (or not specified) W-CDMA mode</p>	<p>Returns following 13 scalar results, in the following order.</p> <ol style="list-style-type: none"> 1. RMS EVM is a floating point number (in percent) of EVM over the entire measurement area 2. Peak EVM error is a floating point number (in percent) of peak EVM in the measurement area 3. Magnitude error is a floating point number (in percent) of average magnitude error over the entire measurement area 4. Phase error is a floating point number (in degree) of average phase error over the entire measurement area 5. I/Q origin offset is a floating point number (in dB) of the I and Q error (magnitude squared) offset from the origin 6. Frequency error is a floating point number (in Hz) of the frequency error in the measured signal 7. Rho is a floating point number of Rho 8. Peak Code Domain Error is a floating point number (in dB) of the Peak Code Domain Error relative to the mean power 9. Peak Code Domain Error Channel Number is the channel number in which the peak code domain error is detected at the max spreading factor. 10. Number of active channels. 11. Time offset is a floating point number (in chip) of the pilot phase timing from the acquisition trigger point. 12. CPICH power over a slot is a floating point number in dB of CPICH power over a measurement slot. In the MS mode the value returned is -999. 13. Average total power over a slot is a floating point number in dB of total RF power over a measurement slot. In the MS mode the value returned is -999.
<p>n=1 (or not specified) 1xEV-DO mode</p> <p>For base stations: SENS:RAD:DEV BTS</p> <p>For meas type: CALC:RHO:TYPE DATA MAC PILot PREamble</p>	<p>Returns following 9 comma-separated scalar results, in the following order, for base transmitter station measurements when the type is <i>NOT</i> set to <i>ALL</i>:</p> <ol style="list-style-type: none"> 1. RMS EVM – a floating point number (in percent) of EVM over the entire measurement area. 2. Peak EVM error – a floating point number (in percent) of peak EVM in the measurement area. 3. Magnitude error – a floating point number (in percent) of average magnitude error over the entire measurement area. 4. Phase error – a floating point number (in degree) of average phase error over the entire measurement area. 5. I/Q Origin Offset – a floating point number (in dB) of the I and Q error (magnitude squared) offset from the origin. 6. Frequency error – a floating point number (in Hz) of the frequency error in the measured signal. 7. Rho – a floating point number of Rho. 8. Number of active channels. 9. Time offset is the time from the trigger to the PN offset – a floating point number (in micro seconds) of PN offset from the trigger point.

n	Results Returned
<p>n=1 (or not specified)</p> <p>1xEV-DO mode</p> <p>For base stations: SENS:RAD:DEV BTS</p> <p>For meas type ALL: CALC:RHO:TYPE ALL</p>	<p>Following 23 scalar results are available for base transmitter station measurements when the type is set to ALL.</p> <p>Rho Overall-1 and Rho Overall-2 specified in 3GPP2 TSG-C4.1 Recommended Minimum Performance Standard for cdma2000 High Rate Data Packet Access Network, 11.4.2 Waveform Quality Measurement section.</p> <ol style="list-style-type: none"> 1. Time offset is the time from the trigger to the PN offset – a floating point number (in micro seconds) of PN offset from the trigger point. 2. RMS EVM (Overall-1) – a floating point number (in percent) of EVM over the entire measurement area. 3. Peak EVM error (Overall-1) – a floating point number (in percent) of peak EVM in the measurement area. 4. Magnitude error (Overall-1) – a floating point number (in percent) of average magnitude error over the entire measurement area. 5. Phase error (Overall-1) – a floating point number (in degree) of average phase error over the entire measurement area. 6. I/Q Origin Offset (Overall-1) – a floating point number (in dB) of the I and Q error (magnitude squared) offset from the origin. 7. Frequency error (Overall-1) – a floating point number (in Hz) of the frequency error in the measured signal. 8. Rho (Overall-1) – a floating point number of Rho. 9. RMS EVM (Overall-2) – a floating point number (in percent) of EVM over the entire measurement area. 10. Peak EVM error (Overall-2) – a floating point number (in percent) of peak EVM in the measurement area. 11. Magnitude error (Overall-2) – a floating point number (in percent) of average magnitude error over the entire measurement area. 12. Phase error (Overall-2) – a floating point number (in degree) of average phase error over the entire measurement area. 13. I/Q Origin Offset (Overall-2) – a floating point number (in dB) of the I and Q error (magnitude squared) offset from the origin. 14. Frequency error (Overall-2) – a floating point number (in Hz) of the frequency error in the measured signal. 15. Rho (Overall-2) – a floating point number of Rho. 16. Number of active channels in Pilot 17. Number of active channels in Mac 18. Number of active channels in Data 19. Preamble Length 20. MAC index 21. Max MAC Inactive channel Power – a floating point number (in dB) of Maximum MAC Inactive Channel Power 22. Max Data Active Channel Power – a floating point number (in dB) of Maximum Data Active Channel Power 23. Min Data Active Channel Power – a floating point number (in dB) of Minimum Data Active Channel Power

n	Results Returned
2 cdmaOne mode	EVM trace – returns error vector magnitude (EVM) data, as trace point values in percent. The first value is the chip 0 decision point. The trace is interpolated for the currently selected points/chips displayed on the front panel. The number of trace points depends on the current measurement interval setting.
2 cdma2000 or W-CDMA mode	EVM trace – returns series of floating point numbers (in percent) that represent each sample in the EVM trace. The first number is the symbol 0 decision point. There are X points per symbol ($X = \text{points/chip}$). Therefore, the decision points are at $0, 1 \times X, 2 \times X, 3 \times X \dots$
2 1xEV-DO mode	Returns series of floating point numbers (in percent) that represent each sample in the EVM trace. The first number is the symbol 0 decision point and there are X points per symbol. Therefore, the decision points are at $0, 1xX, 2xX, 3xX\dots$ ($X = \text{the number of points per chip}$) This traces is available when the Measurement Channel Type Selection is Pilot, MAC or Data (CALCulate:RHO:TYPE = PILot MAC DATA) In all cases, returns one full slot data points, but only portion of EVM computation is performed are valid. All other portion is 0.0
3 cdmaOne mode	Magnitude error trace – returns magnitude error data, as trace point values, in percent. The first value is the chip 0 decision point. The trace is interpolated for the currently selected points/chips displayed on the front panel. The number of trace points depends on the current measurement interval setting.
3 cdma2000, W-CDMA, or 1xEV-DO mode	Magnitude error trace – returns series of floating point numbers (in percent) that represent each sample in the magnitude error trace. The first number is the symbol 0 decision point. There are X points per symbol ($X = \text{points/chip}$). Therefore, the decision points are at $0, 1 \times X, 2 \times X, 3 \times X \dots$ For 1xEV-DO: this traces is available when the Measurement Channel Type Selection is Pilot, MAC or Data (CALCulate:RHO:TYPE = PILot MAC DATA) In all cases, returns one full slot data points, but only portion of EVM computation is performed are valid. All other portion is 0.0
4 cdmaOne mode	Phase error trace – returns phase error data, as trace point values, in degrees. The first value is the symbol 0 decision point. The trace is interpolated for the currently selected chips/symbol displayed on the front panel. The number of trace points depends on the current measurement interval setting.

n	Results Returned
<p>4</p> <p>cdma2000, W-CDMA, or 1xEV-DO mode</p>	<p>Phase error trace – returns series of floating point numbers (in degrees) that represent each sample in the phase error trace. There are X points per symbol ($X = \text{points/ chip}$). Therefore, the decision points are at $0, 1 \times X, 2 \times X, 3 \times X \dots$</p> <p>For 1xEV-DO: this traces is available when the Measurement Channel Type Selection is Pilot, MAC or Data (CALCulate:RHO:TYPE = PILOt MAC DATA) In all cases, returns one full slot data points, but only portion of EVM computation is performed are valid. All other portion is 0.0</p>
<p>5</p> <p>cdmaOne mode</p>	<p>Corrected measured data – returns a series of floating point numbers that alternately represent I and Q pairs of the corrected measured trace data. The magnitude of each I and Q pair are normalized to 1.0.</p> <p>The number of trace points depends on the current measurement interval setting.</p> <p>The numbers are sent in the following order:</p> <p style="padding-left: 40px;">In-phase (I) sample, of symbol 0 decision point Quadrature-phase (Q) sample, of symbol 0 decision point ... In-phase (I) sample, of symbol 1 decision point Quadrature-phase (Q) sample, of symbol 1 decision point ...</p> <p>The trace can be interpolated to 2,4, 8 points/chip selected with the display Points/Chip softkey. This will change the number of points between decision points in the trace, changing the number of I/Q pairs sent for each decision point.</p>
<p>5</p> <p>cdma2000, W-CDMA, 1xEV-DO mode</p>	<p>Corrected measured trace – returns series of floating point numbers that alternately represent I and Q pairs of the corrected measured trace. The magnitude of each I and Q pair are normalized to 1.0. The first number is the in-phase (I) sample of symbol 0 decision point and the second is the quadrature-phase (Q) sample of symbol 0 decision point. There are X points per symbol ($X = \text{points/chip}$), so the series of numbers is:</p> <p style="padding-left: 40px;">1st number = I of the symbol 0 decision point 2nd number = Q of the symbol 0 decision point ... $(2 \times X) + 1$, number = I of the symbol 1 decision point $(2 \times X) + 2$, number = Q of the symbol 1 decision point ... $(2 \times X) \times N\text{th} + 1$ number = I of the symbol N decision point $(2 \times X) \times N\text{th} + 2$ number = Q of the symbol N decision point</p> <p>For 1xEV-DO: this traces is available when the Measurement Channel Type Selection is Pilot, MAC or Data (CALCulate:RHO:TYPE = PILOt MAC DATA) In all cases, returns one full slot data points, but only portion of EVM computation is performed are valid. All other portion is 0.0</p>

n	Results Returned
6 cdmaOne mode	<p>Reference IQ data – returns a series of floating point numbers that alternately represent I and Q pairs of the reference trace data.</p> <p>The number of trace points depends on the current measurement interval and points per chip settings.</p> <p>The numbers are sent in the following order:</p> <ul style="list-style-type: none"> In-phase (I) sample, of symbol 0 decision point Quadrature-phase (Q) sample, of symbol 0 decision point ... In-phase (I) sample, of symbol 1 decision point Quadrature-phase (Q) sample, of symbol 1 decision point ... <p>The trace can be interpolated to 2,4,8 points/chip selected with the display Points/Chip softkey.</p>
6 cdma2000 mode	<p>Returns 6 scalar values of the pass/fail (0=passed, or 1=failed) results determined by testing the EVM and peak EVM.</p> <ol style="list-style-type: none"> 1. Test result of EVM 2. Test result of Peak EVM 3. Test result of Rho 4. Test result of Peak Code Domain Error 5. Test result of Time Offset 6. Test result of Phase Error
6 1xEV-DO mode	<p>The same as n=2. (Overall-1)</p> <p>This trace is available when the Measurement Channel Type Selection is All (CALCulate:RHO:TYPE = ALL)</p> <p>(Rho Overall-1 and Rho Overall-2 as specified in 3GPP2 TSG-C4.1 Recommended Minimum Performance Standard for cdma2000 High Rate Data Packet Access Network, 11.4.2 Waveform Quality Measurement section.)</p> <p>n=6, 7, 8, 9 are for Overall-1 data trace n=10, 11, 12, 13 are for Overall-2 data trace</p> <p>In all cases, returns one full slot data points, but only portion of EVM computation is performed are valid. All other portion is 0.0</p>
6 W-CDMA mode	<p>Returns 6 comma-separated scalar values of the pass/fail (0.0 = passed, or 1.0 = failed) results determined by testing the EVM and peak EVM.</p> <ol style="list-style-type: none"> 1. Test result of EVM 2. Test result of Peak EVM 3. Test result of Rho 4. Test result of Peak Code Domain Error 5. Test result of Frequency Error 6. Test result of CPICH power over a frame (If MS is selected, this always returns 0.0.)

n	Results Returned
7 cdmaOne mode	<p>Complimentary filtered measured data – returns a series of floating point numbers that alternately represent I and Q pairs of the complimentary filtered measured data. This is inverse filtered data of the inter-symbol interference in CDMA signals due to the digital transmission filters defined in the standard as well as the base station phase equalization filter.</p> <p>The number of trace points depends on the current measurement interval setting.</p> <p>The numbers are sent in the following order:</p> <ul style="list-style-type: none"> In-phase (I) sample, of symbol 0 decision point Quadrature-phase (Q) sample, of symbol 0 decision point ... In-phase (I) sample, of symbol 1 decision point Quadrature-phase (Q) sample, of symbol 1 decision point ... <p>The trace can be interpolated to 2,4,8 points/chip selected with the display Points/Chip softkey. This will change the number of points between decision points in the trace, changing the number of I/Q pairs sent for each decision point.</p>
7 cdma2000 mode	<p>Returns series of floating point numbers of code level, code index, power (in dB), time offset (in ns), phase offset (in rad), and code domain error (in dB). The total number of results are six times of “number of active channels”. The number of active channels can be obtained by the 10th result of FETCh:RHO0 command.</p>
7 1xEV-DO mode	<p>The same as n=3. (Overall-1)</p> <p>This trace is available when the Measurement Channel Type Selection is All (CALCulate:RHO:TYPE = ALL)</p> <p>(Rho Overall-1 and Rho Overall-2 as specified in 3GPP2 TSG-C4.1 Recommended Minimum Performance Standard for cdma2000 High Rate Data Packet Access Network, 11.4.2 Waveform Quality Measurement section.)</p> <p>n=6, 7, 8, 9 are for Overall-1 data trace n=10, 11, 12, 13 are for Overall-2 data trace</p> <p>In all cases, returns one full slot data points, but only portion of EVM computation is performed are valid. All other portion is 0.0</p>

n	Results Returned
<p>7 W-CDMA mode</p>	<p>With a device of BTS, it returns a series of floating point numbers: symbol rate (ex. 7.5 ksps), OVFSF code number, a dummy value, power level and code domain error for the active channels.</p> <p>With a device of MS, it returns a series of floating point numbers: symbol rate (ex. 15 ksps), OVFSF code number, 1.0 (I) or -1.0 (Q), power level and code domain error for the active channels. The results would look like the following:</p> <p style="padding-left: 40px;">1st number = Symbol Rate for 1st Active Channel 2nd number = OVFSF Code number for 1st Active Channel 3rd number = (in BTS) -999, or (in MS) either -1 (I) or +1 (Q) for 1st Active Channel 4th number = Power Level (in dB) for 1st Active Channel 5th number = Code Domain Error for 1st Active Channel ... (N-1)*5+1 number = Symbol Rate for Nth Active Channel (N-1)*5+2 number = OVFSF Code number for Nth Active Channel (N-1)*5+3 number = -999 (in BTS), or either -1 (I) or +1 (Q) (in MS) for Nth Active Channel (N-1)*5+4 number = Power Level (in dB) for Nth Active Channel N*5 number = Code Domain Error for Nth Active Channel</p> <p>Number of active channel is given by 10th parameter of :MEASure:RHO[1].</p>
<p>8 cdmaOne mode</p>	<p>Complimentary filtered reference data – returns a series of floating point numbers that alternately represent I and Q pairs of the complimentary filtered reference data. This is inverse filtered data of the inter-symbol interference in CDMA signals due to the digital transmission filters defined in the standard as well as the base station phase equalization filter.</p> <p>The number of trace points depends on the current measurement interval setting.</p> <p>The numbers are sent in the following order:</p> <p style="padding-left: 40px;">In-phase (I) sample, of symbol 0 decision point Quadrature-phase (Q) sample, of symbol 0 decision point ... In-phase (I) sample, of symbol 1 decision point Quadrature-phase (Q) sample, of symbol 1 decision point ...</p> <p>The trace can be interpolated to 2,4,8 points/chip selected with the display Points/Chip softkey. This will change the number of points between decision points in the trace, changing the number of I/Q pairs sent for each decision point.</p>

n	Results Returned
<p>8 W-CDMA mode</p>	<p>Returns a series of floating point numbers (in dB) that represents all the code domain powers.</p> <p>With a device of BTS, there are 512 numbers. If the active channel occupies more than the max spreading factor (7.5 ksps) the power is duplicated (active symbol rate/7.5 ksps) times.</p> <p>1st number = 1st code power over the slot 2nd number = 2nd code power over the slot ... Nth number = Nth code power over the slot</p> <p>With a device of MS, there are 256 I/Q pairs. If the active channel occupies more than the max spreading factor (15 ksps) the power is duplicated (active symbol rate / 15 ksps) times.</p> <p>1st number = 1st in-phase code power over the slot 2nd number = 1st quad-phase code power over the slot ... (2*N-1) number = Nth in-phase code power over the slot (2 *N) number = Nth quad-phase code power over a slot</p> <p>N = the number of codes detected. The total number of codes varies because of the different symbol rates of each code.</p>
<p>8 1xEV-DO mode</p>	<p>The same as n=4. (Overall-1)</p> <p>This trace is available when the Measurement Channel Type Selection is All (CALCulate:RHO:TYPE = ALL)</p> <p>(Rho Overall-1 and Rho Overall-2 as specified in 3GPP2 TSG-C4.1 Recommended Minimum Performance Standard for cdma2000 High Rate Data Packet Access Network, 11.4.2 Waveform Quality Measurement section.)</p> <p>n=6, 7, 8, 9 are for Overall-1 data trace n=10, 11, 12, 13 are for Overall-2 data trace</p> <p>In all cases, returns one full slot data points, but only portion of EVM computation is performed are valid. All other portion is 0.0</p>

n	Results Returned
<p>9 1xEV-DO mode</p>	<p>The same as n=5. (Overall-1)</p> <p>This trace is available when the Measurement Channel Type Selection is All (CALCulate:RHO:TYPE = ALL)</p> <p>(Rho Overall-1 and Rho Overall-2 as specified in 3GPP2 TSG-C4.1 Recommended Minimum Performance Standard for cdma2000 High Rate Data Packet Access Network, 11.4.2 Waveform Quality Measurement section.)</p> <p>n=6, 7, 8, 9 are for Overall-1 data trace n=10, 11, 12, 13 are for Overall-2 data trace</p> <p>In all cases, returns one full slot data points, but only portion of EVM computation is performed are valid. All other portion is 0.0</p>
<p>10 1xEV-DO mode</p>	<p>The same as n=2. (Overall-2)</p> <p>This trace is available when the Measurement Channel Type Selection is All (CALCulate:RHO:TYPE = ALL)</p> <p>(Rho Overall-1 and Rho Overall-2 as specified in 3GPP2 TSG-C4.1 Recommended Minimum Performance Standard for cdma2000 High Rate Data Packet Access Network, 11.4.2 Waveform Quality Measurement section.)</p> <p>n=6, 7, 8, 9 are for Overall-1 data trace n=10, 11, 12, 13 are for Overall-2 data trace</p> <p>In all cases, returns one full slot data points, but only portion of EVM computation is performed are valid. All other portion is 0.0</p>
<p>11 cdmaOne mode</p>	<p>Corrected measured data – returns a series of floating point numbers that alternately represent I and Q pairs of the corrected measured trace data. The magnitude of each I and Q pair are normalized to 1.0.</p> <p>The number of trace points depends on the current setting for the number of displayed I/Q points in the I/Q display.</p> <p>The numbers are sent in the following order:</p> <p style="padding-left: 40px;">In-phase (I) sample, of symbol 0 decision point Quadrature-phase (Q) sample, of symbol 0 decision point ... In-phase (I) sample, of symbol 1 decision point Quadrature-phase (Q) sample, of symbol 1 decision point ...</p> <p>The trace can be interpolated to 2,4,8 points/chip selected with the display Points/Chip softkey. This will change the number of points between decision points in the trace, changing the number of I/Q pairs sent for each decision point.</p>

n	Results Returned
<p>11 1xEV-DO mode</p>	<p>The same as n=2. (Overall-2)</p> <p>This trace is available when the Measurement Channel Type Selection is All (CALCulate:RHO:TYPE = ALL)</p> <p>(Rho Overall-1 and Rho Overall-2 as specified in 3GPP2 TSG-C4.1 Recommended Minimum Performance Standard for cdma2000 High Rate Data Packet Access Network, 11.4.2 Waveform Quality Measurement section.)</p> <p>n=6, 7, 8, 9 are for Overall-1 data trace n=10, 11, 12, 13 are for Overall-2 data trace</p> <p>In all cases, returns one full slot data points, but only portion of EVM computation is performed are valid. All other portion is 0.0</p>
<p>12 1xEV-DO mode</p>	<p>The same as n=4. (Overall-2)</p> <p>This trace is available when the Measurement Channel Type Selection is All (CALCulate:RHO:TYPE = ALL)</p> <p>(Rho Overall-1 and Rho Overall-2 as specified in 3GPP2 TSG-C4.1 Recommended Minimum Performance Standard for cdma2000 High Rate Data Packet Access Network, 11.4.2 Waveform Quality Measurement section.)</p> <p>n=6, 7, 8, 9 are for Overall-1 data trace n=10, 11, 12, 13 are for Overall-2 data trace</p> <p>In all cases, returns one full slot data points, but only portion of EVM computation is performed are valid. All other portion is 0.0</p>

n	Results Returned
<p>13 cdmaOne mode</p>	<p>Complimentary filtered measured data – returns a series of floating point numbers that alternately represent I and Q pairs of the complimentary filtered measured data. This is inverse filtered data of the inter-symbol interference in CDMA signals due to the digital transmission filters defined in the standard as well as the base station phase equalization filter.</p> <p>The number of trace points depends on the current setting for the number of displayed I/Q points in the I/Q display.</p> <p>The numbers are sent in the following order:</p> <ul style="list-style-type: none"> In-phase (I) sample, of symbol 0 decision point Quadrature-phase (Q) sample, of symbol 0 decision point ... In-phase (I) sample, of symbol 1 decision point Quadrature-phase (Q) sample, of symbol 1 decision point ... <p>The trace can be interpolated to 2,4,8 points/chip selected with the display Points/Chip softkey. This will change the number of points between decision points in the trace, changing the number of I/Q pairs sent for each decision point.</p>
<p>13 1xEV-DO mode</p>	<p>The same as n=5. (Overall-2)</p> <p>This trace is available when the Measurement Channel Type Selection is All (CALCulate:RHO:TYPE = ALL)</p> <p>(Rho Overall-1 and Rho Overall-2 as specified in 3GPP2 TSG-C4.1 Recommended Minimum Performance Standard for cdma2000 High Rate Data Packet Access Network, 11.4.2 Waveform Quality Measurement section.)</p> <p>n=6, 7, 8, 9 are for Overall-1 data trace n=10, 11, 12, 13 are for Overall-2 data trace</p> <p>In all cases, returns one full slot data points, but only portion of EVM computation is performed are valid. All other portion is 0.0</p>

n	Results Returned
<p>14 1xEV-DO mode</p>	<p>The same as n=5. (Overall-2) I/Q trace data is descrambled.</p> <p>This trace is available when the Measurement Channel Type Selection is All (CALCulate:RHO:TYPE = ALL)</p> <p>(Rho Overall-1 and Rho Overall-2 as specified in 3GPP2 TSG-C4.1 Recommended Minimum Performance Standard for cdma2000 High Rate Data Packet Access Network, 11.4.2 Waveform Quality Measurement section.)</p> <p>n=6, 7, 8, 9 are for Overall-1 data trace n=10, 11, 12, 13 are for Overall-2 data trace</p> <p>In all cases, returns one full slot data points, but only portion of EVM computation is performed are valid. All other portion is 0.0</p>
<p>15 1xEV-DO mode</p>	<p>Returns 10 comma-separated scalar values of the pass/fail (0.0=passed, or 1.0=failed) results determined by testing the EVM, Peak EVM:</p> <ol style="list-style-type: none"> 1. Test result of EVM 2. Test result of Peak EVM 3. Test result of Rho 4. Test result of Frequency Error <p>Following Timing and Phase results are valid only Multichannel Estimator is On and existence of multiple codes. When the measurement is not valid, the results are 0.0</p> <ol style="list-style-type: none"> 5. Test result of Timing 6. Test result of Phase <p>Following Pilot Offset result is valid only external trigger is selected. When the measurement is not valid, the result is 0.0</p> <ol style="list-style-type: none"> 7. Test result of Pilot Phase 8. Test result of Max MAC Inactive Channel Power 9. Test result of Max Data Active Channel Power 10. Test result of Min Data Active Channel Power <p>This trace is available when the Measurement Channel Type Selection is All (CALCulate:RHO:TYPE = ALL)</p> <p>(Rho Overall-1 and Rho Overall-2 as specified in 3GPP2 TSG-C4.1 Recommended Minimum Performance Standard for cdma2000 High Rate Data Packet Access Network, 11.4.2 Waveform Quality Measurement section.)</p> <p>n=6, 7, 8, 9 are for Overall-1 data trace n=10, 11, 12, 13 are for Overall-2 data trace</p> <p>In all cases, returns one full slot data points, but only portion of EVM computation is performed are valid. All other portion is 0.0</p>

Spectrum (Frequency Domain) Measurement

For E4406A this measures the amplitude of your input signal with respect to the frequency. It provides spectrum analysis capability using FFT (fast Fourier transform) measurement techniques. You must select the appropriate mode using INSTRUMENT:SELEct, to use these commands.

For PSA this measures the amplitude of your input signal with respect to the frequency. It provides spectrum analysis capability using FFT (fast Fourier transform) measurement techniques. You must be in the Basic, cdmaOne, cdma2000, 1xEV-DO, W-CDMA, GSM (w/EDGE), NADC, or PDC mode to use these commands. Use INSTRUMENT:SELEct, to select the mode.

The general functionality of CONFigure, FETCh, MEASure, and READ are described at the beginning of this section. See the SENSE:SPECTrum commands for more measurement related commands.

```
:CONFigure:SPECTrum
:INITiate:SPECTrum
:FETCh:SPECTrum [n] ?
:READ:SPECTrum [n] ?
:MEASure:SPECTrum [n] ?
```

Front Panel

Access: **Measure, Spectrum (Freq Domain)**

After the measurement is selected, press **Restore Meas Defaults** to restore factory defaults.

Measurement Results Available

n	Results Returned
0	Returns unprocessed I/Q trace data, as a series of trace point values, in volts. The I values are listed first in each pair, using the 0 through even-indexed values. The Q values are the odd-indexed values.

n	Results Returned
n=1 (or not specified)	<p>Returns the following scalar results:</p> <ol style="list-style-type: none"> 1. FFT peak is the FFT peak amplitude. 2. FFT frequency is the FFT frequency of the peak amplitude. 3. FFT points is the Number of points in the FFT spectrum. 4. First FFT frequency is the frequency of the first FFT point of the spectrum. 5. FFT spacing is the frequency spacing between the FFT points of the spectrum. 6. Time domain points is the number of points in the time domain trace used for the FFT. The number of points doubles if the data is complex instead of real. See the time domain scaler description below. 7. First time point is the time of the first time domain point, where time zero is the trigger event. 8. Time spacing is the time spacing between the time domain points. The time spacing value doubles if the data is complex instead of real. See the time domain scaler description below. 9. Time domain returns a 1 if time domain is complex (I/Q) and complex data will be returned. It returns a 0 if the data is real. (raw ADC samples) When this value is 1 rather than 0 (complex vs. real data), the time domain points and the time spacing scalers both increase by a factor of two. 10. Scan time is the total scan time of the time domain trace used for the FFT. The total scan time = (time spacing) X (time domain points – 1) 11. Current average count is the current number of data measurements that have already been combined, in the averaging calculation.
2, Service mode only	Returns the trace data of the log-magnitude versus time. (That is, the RF envelope.)
3	Returns the I and Q trace data. It is represented by I and Q pairs (in volts) versus time.
4	Returns spectrum trace data. That is, the trace of log-magnitude versus frequency. (The trace is computed using a FFT.)
5, Service mode only	Returns the averaged trace data of log-magnitude versus time. (That is, the RF envelope.)
6	Not used.
7	Returns the averaged spectrum trace data. That is, the trace of the averaged log-magnitude versus frequency.
8	Not used.
9, Service mode only	Returns a trace containing the shape of the FFT window.

n	Results Returned
10, Service mode only	Returns trace data of the phase of the FFT versus frequency.
11, cdma2000, 1xEV-DO, W-CDMA, Basic modes only	Returns linear spectrum trace data values in Volts RMS.
12, cdma2000, 1xEV-DO, W-CDMA, Basic modes only	Returns averaged linear spectrum trace data values in Volts RMS.

Waveform (Time Domain) Measurement

For E4406A this measures the amplitude of your input signal with respect to the frequency. It provides spectrum analysis capability using FFT (fast Fourier transform) measurement techniques. You must select the appropriate mode using INSTRUMENT:SElect, to use these commands.

For PSA this measures the amplitude of your input signal with respect to the frequency. It provides spectrum analysis capability using FFT (fast Fourier transform) measurement techniques. You must be in the Basic, cdmaOne, cdma2000, 1xEV-DO, W-CDMA, GSM (w/EDGE), NADC, or PDC mode to use these commands. Use INSTRUMENT:SElect, to select the mode.

The general functionality of CONFigure, FETCh, MEASure, and READ are described at the beginning of this section. See the SENSE:WAVEform commands for more measurement related commands.

```
:CONFigure:WAVEform
:INITiate:WAVEform
:FETCh:WAVEform [n] ?
:READ:WAVEform [n] ?
:MEASure:WAVEform [n] ?
```

Front Panel

Access: **Measure, Waveform (Time Domain)**

After the measurement is selected, press **Restore Meas Defaults** to restore factory defaults.

Measurement Results Available

n	Results Returned
0 (see also 5)	Returns unprocessed I/Q trace data, as a series of trace point values, in volts. The I values are listed first in each pair, using the 0 through even-indexed values. The Q values are the odd-indexed values.

n	Results Returned
n=1 (or not specified)	<p>Returns the following scalar results:</p> <ol style="list-style-type: none"> 1. Sample time is a floating point number representing the time between samples when using the trace queries (n=0,2,etc). 2. Mean power is the mean power (in dBm). This is either the power across the entire trace, or the power between markers if the markers are enabled. If averaging is on, the power is for the latest acquisition. 3. Mean power averaged is the power (in dBm) for N averages, if averaging is on. This is either the power across the entire trace, or the power between markers if the markers are enabled. If averaging is on, the power is for the latest acquisition. If averaging is off, the value of the mean power averaged is the same as the value of the mean power. 4. Number of samples is the number of data points in the captured signal. This number is useful when performing a query on the signal (i.e. when n=0,2,etc.). 5. Peak-to-mean ratio has units of dB. This is the ratio of the maximum signal level to the mean power. Valid values are only obtained with averaging turned off. If averaging is on, the peak-to-mean ratio is calculated using the highest peak value, rather than the displayed average peak value. 6. Maximum value is the maximum of the most recently acquired data (in dBm). 7. Minimum value is the minimum of the most recently acquired data (in dBm).
2	<p>Returns trace point values of the entire captured signal envelope trace data. These data points are floating point numbers representing the power of the signal (in dBm). There are N data points, where N is the number of samples. The period between the samples is defined by the sample time.</p>
3, Option B7C with cdma2000, W-CDMA, Basic modes only (E4406A only)	<p>Returns magnitude values of the time data in Volts peak.</p>
4, Option B7C with cdma2000, W-CDMA, Basic modes only (E4406A only)	<p>Returns values of phase data in degrees.</p>

READ Subsystem

The READ? commands are used with several other commands and are documented in the section on the “[MEASure Group of Commands](#)” on [page 213](#).

Initiate and Read Measurement Data

`:READ:<measurement> [n] ?`

A READ? query must specify the desired measurement. It will cause a measurement to occur without changing any of the current settings and will return any valid results. The code number *n* selects the kind of results that will be returned. The available measurements and data results are described in the “[MEASure Group of Commands](#)” on [page 213](#).

SENSE Subsystem

These commands are used to set the instrument state parameters so that you can measure a particular input signal. Some SENSE commands are only for use with specific measurements found under the MEASURE key menu or the “MEASURE Group of Commands” on page 213. The measurement must be active before you can use these commands.

The SCPI default for the format of any data output is ASCII. The format can be changed to binary with FORMat:DATA which transports faster over the bus.

Adjacent Channel Power Measurement

Commands for querying the adjacent channel power measurement results and for setting to the default values are found in the “MEASURE Group of Commands” on page 213. The equivalent front panel keys for the parameters described in the following commands, are found under the **Meas Setup** key, after the **ACP** or **ACPR** measurement has been selected from the **MEASURE** key menu.

Adjacent Channel Power—Average Count

```
[ :SENSE ] :ACP:AVERAGE:COUNT <integer>
```

```
[ :SENSE ] :ACP:AVERAGE:COUNT?
```

Set the number of data acquisitions that will be platform averaged. After the specified number of average counts, the average mode (termination control) setting determines the average action.

Factory Preset: 10 for cdma2000, W-CDMA

20 for Basic, cdmaOne, iDEN (E4406A)

Range: 1 to 10,000

Remarks: Use INSTRument:SElect to set the mode.

Front Panel

Access: **Meas Setup**

Adjacent Channel Power—Averaging State

```
[ :SENSE ] :ACP:AVERAGE [ :STATE ] OFF | ON | 0 | 1
```

```
[ :SENSE ] :ACP:AVERAGE [ :STATE ] ?
```

Turn the averaging function On or Off.

Factory Preset: On

Off for iDEN mode (E4406A)

Remarks: Use INSTRument:SElect to set the mode.

Front Panel

Access: **Meas Setup**

Adjacent Channel Power—Averaging Termination Control

```
[ :SENSe ] :ACP:AVERAge:TCONtrol EXPonential | REPeat
```

```
[ :SENSe ] :ACP:AVERAge:TCONtrol?
```

Select the type of termination control used for averaging. This determines the averaging action after the specified number of data acquisitions (average count) is reached.

EXPonential – Each successive data acquisition after the average count is reached, is exponentially weighted and combined with the existing average.

REPeat – After reaching the average count, the averaging is reset and a new average is started.

Factory Preset: REPeat for PSA cdmaOne, cdma2000, W-CDMA

REPeat for E4406A Basic, cdmaOne, cdma2000, W-CDMA

EXPonential for E4406A iDEN

EXPonential for NADC, PDC

Remarks: Use INSTRument:SElect to set the mode.

Adjacent Channel Power—Type of Carrier Averaging

```
[ :SENSe ] :ACP:AVERAge:TYPE MAXimum | RMS
```

```
[ :SENSe ] :ACP:AVERAge:TYPE?
```

Selects the type of averaging to be used for the measurement of the carrier.

Factory Preset: RMS

Remarks: You must be in Basic (E4406A), or cdmaOne mode to use this command. Use INSTRument:SElect to set the mode.

History: E4406A:
Revision A.03.00 or later, in cdmaOne revision A.04.00

Front Panel

Access: **Meas Setup, Avg Mode**

Adjacent Channel Power—Carrier Channel BW

Basic, iDEN mode (E4406A)

`[:SENSE] :ACP:BANDwidth | BWIDth :INTEgration <freq>`

`[:SENSE] :ACP:BANDwidth | BWIDth :INTEgration ?`

cdma2000, W-CDMA mode

`[:SENSE] :ACP:BANDwidth [n] | BWIDth [n] :INTEgration <freq>`

`[:SENSE] :ACP:BANDwidth [n] | BWIDth [n] :INTEgration ?`

cdmaOne mode

`[:SENSE] :ACP:BANDwidth [n] | BWIDth [n] :INTEgration [m] <freq>`

`[:SENSE] :ACP:BANDwidth [n] | BWIDth [n] :INTEgration [m] ?`

Set the Integration bandwidth that will be used for the main (carrier) channel.

BANDwidth[n] | BWIDth[n]: m=1 is base station and 2 is mobiles. The default is base station (1).

INTEgration[n]: m=1 is cellular bands and 2 is pcs bands. The default is cellular.

Factory Preset:

Mode	Format (Modulation Standard)		
Basic (E4406A)	1.23 MHz		
cdmaOne	1.23 MHz		
iDEN (E4406A)	18 kHz		
cdma2000	1.23 MHz		
W-CDMA	3.84 MHz		

Range: 300 Hz to 20 MHz for Basic (E4406A), cdmaOne, cdma2000, or W-CDMA mode

1 kHz to 5 MHz for iDEN (E4406A)

Default Unit: Hz

Remarks: With measurement type set at (TPR) total power reference, 1.40 MHz is sometimes used. Using 1.23 MHz will give a power that is very nearly identical to the 1.40 MHz value, and using 1.23 MHz will also yield the correct power spectral density with

measurement type set at (PSD) reference. However, a setting of 1.40 MHz will not give the correct results with measurement type set at PSD reference.

For PSA you must be in cdmaOne, cdma2000, or W-CDMA mode to use this command. Use INSTRUMENT:SElect to set the mode.

For E4406A you must be in Basic, cdmaOne, cdma2000, W-CDMA, or iDEN mode to use this command. Use INSTRUMENT:SElect to set the mode.

Adjacent Channel Power—Dynamic Range

`[:SENSe] :ACP:DYNamic [n] :RANge [m] HIGH | NORMAl | MODified`

`[:SENSe] :ACP:DYNamic [n] :RANge [m] ?`

Select a dynamic range optimization.

High - chooses settings that provide better dynamic range (better signal to noise ratio) at the expense of longer measurement times. This is a better choice for CDMA signals with multiple carriers turned on at the same time.

Normal - lets the measurement automatically choose settings that trade off dynamic range for faster measurement speed. This is a good choice for making CDMA measurements on a signal with only one carrier turned on at a time.

Modified- is not a customer settable option. This choice is automatically selected depending on your selection of other related settings in the advanced measurement setup, like the number of FFT segments.

Dynamic [n] n=1 is BTS (base station) and 2 is MS (mobile station).
The default is base station (1).

Range [m] m=1 is cellular bands (IS-95A) and 2 is pcs bands
(J-STD-008) for cdmaOne. The default is cellular (1).

Factory Preset: NORMAl

Remarks: You must be in the cdmaOne mode to use this
command. Use INSTRUMENT:SElect to set the mode.

History: E4406A:
Added A.04.00. Revised for A.05.00.

Adjacent Channel Power—Reference Channel FFT Segments

`[:SENSe] :ACP:FFTSegment <integer>`

[:SENSE] :ACP:FFTSegment?

Selects the number of FFT segments used in making the measurement of the reference channel (carrier). In automatic mode the measurement optimizes the number of FFT segments required for the shortest measurement time. The minimum number of segments required to make a measurement is set by your desired measurement bandwidth. Selecting more than the minimum number of segments will give you more dynamic range for making the measurement, but the measurement will take longer to execute.

To use this command you must first set SENSE:ACP:FFTS:AUTO to off.

Factory Preset: 1

Range: 1 to 12

Remarks: You must be in Basic (E4406A), or cdmaOne mode to use this command. Use INSTRUMENT:SELEct to set the mode.

History: E4406A:
Revision A.03.00 or later, in cdmaOne revision A.04.00

Adjacent Channel Power—Reference Channel FFT Segments State

[:SENSE] :ACP:FFTSegment:AUTO OFF | ON | 0 | 1

[:SENSE] :ACP:FFTSegment:AUTO?

The automatic mode selects the optimum number of FFT segments to measure the reference channel (carrier), while making the fastest possible measurement.

Factory Preset: ON

Remarks: You must be in Basic (E4406A), or cdmaOne mode to use this command. Use INSTRUMENT:SELEct to set the mode.

History: E4406A:
Revision A.03.00 or later, in cdmaOne revision A.04.00

Adjacent Channel Power—Frequency Span Query

[:SENSE] :ACP:FREQuency:SPAN?

Returns the span of the spectrum view.

Remarks: You must be in Basic (E4406A), or cdmaOne mode to use this command. Use INSTRUMENT:SELEct to set the mode.

History: E4406A:
Revision A.05.00 or later

Adjacent Channel Power—Absolute Amplitude Limits

iDEN mode (E4406A)

```
[ :SENSe ] :ACP:OFFSet:ABSolute <power>
```

```
[ :SENSe ] :ACP:OFFSet:ABSolute?
```

Basic (E4406A), cdmaOne mode

```
[ :SENSe ] :ACP:OFFSet:LIST:ABSolute  
<power>, <power>, <power>, <power>, <power>
```

```
[ :SENSe ] :ACP:OFFSet:LIST:ABSolute?
```

cdma2000, W-CDMA mode

```
[ :SENSe ] :ACP:OFFSet [n] :LIST:ABSolute  
<power>, <power>, <power>, <power>, <power>
```

```
[ :SENSe ] :ACP:OFFSet [n] :LIST:ABSolute?
```

Sets the absolute amplitude levels to test against for each of the custom offsets. The list must contain five (5) entries. If there is more than one offset, the offset closest to the carrier channel is the first one in the list. [:SENSe]:ACP:OFFSet[n]:LIST[m]:TEST selects the type of testing to be done at each offset.

You can turn off (not use) specific offsets with the [:SENSe]:ACP:OFFSet[n]:LIST:STATe command.

The query returns the five (5) sets of the real numbers that are the current absolute amplitude test limits.

Offset[n] n=1 is base station and 2 is mobiles. The default is base station (1).

List[n] m=1 is cellular bands and 2 is pcs bands. The default is cellular.

Factory Preset:

Mode	Variant	Offset A	Offset B	Offset C	Offset D	Offset E
Basic (E4406A)		0 dBm	0 dBm	0 dBm	0 dBm	0 dBm
cdmaOne	BS cellular	0 dBm	0 dBm	0 dBm	0 dBm	0 dBm
	BS pcs	0 dBm	- 13 dBm	- 13 dBm	0 dBm	0 dBm
	MS cellular	0 dBm	0 dBm	0 dBm	0 dBm	0 dBm
	MS pcs	0 dBm	- 13 dBm	- 13 dBm	0 dBm	0 dBm
cdma2000		50 dBm	50 dBm	50 dBm	50 dBm	50 dBm

Mode	Variant	Offset A	Offset B	Offset C	Offset D	Offset E
W-CDMA		50 dBm	50 dBm	50 dBm	50 dBm	50 dBm
iDEN (E4406A)		0 dBm	n/a	n/a	n/a	n/a

Range: -200.0 dBm to 50.0 dBm

Default Unit: dBm

Remarks: For PSA you must be in cdmaOne, cdma2000, or W-CDMA mode to use this command. Use INSTRUMENT:SELEct to set the mode.

For E4406A you must be in Basic, cdmaOne, cdma2000, W-CDMA, or iDEN mode to use this command. Use INSTRUMENT:SELEct to set the mode.

Adjacent Channel Power—Type of Offset Averaging

`[:SENSE] :ACP:OFFSet:LIST:AVERAge:TYPE MAXimum | RMS`

`[:SENSE] :ACP:OFFSet:LIST:AVERAge:TYPE?`

Selects the type of averaging to be used for the measurement at each offset. You can turn off (not use) specific offsets with the SENS:ACP:OFFSet:LIST:STATe command.

Factory Preset:

Mode	Offset A	Offset B	Offset C	Offset D	Offset E
Basic (E4406A)	RMS	RMS	RMS	RMS	RMS
cdmaOne	RMS	RMS	RMS	RMS	RMS

Remarks: You must be in Basic (E4406A), or cdmaOne mode to use this command. Use INSTRUMENT:SELEct to set the mode.

History: (E4406A):
Revision A.03.00 or later, in cdmaOne revision A.04.00

Adjacent Channel Power—Define Resolution Bandwidth List

iDEN mode (E4406A)

`[:SENSE] :ACP:OFFSet:BANDwidth | BWIDth <res_bw>`

`[:SENSE] :ACP:OFFSet:BANDwidth | BWIDth?`

Basic mode (E4406A)

```
[[:SENSe]:ACP:OFFSet:LIST:BANDwidth|BWIDth
<res_bw>,<res_bw>,<res_bw>,<res_bw>,<res_bw>
```

```
[[:SENSe]:ACP:OFFSet:LIST:BANDwidth|BWIDth?
```

cdma2000, W-CDMA mode

```
[[:SENSe]:ACP:OFFSet[n]:LIST:BANDwidth|BWIDth
<res_bw>,<res_bw>,<res_bw>,<res_bw>,<res_bw>
```

```
[[:SENSe]:ACP:OFFSet[n]:LIST:BANDwidth|BWIDth?
```

cdmaOne mode

```
[[:SENSe]:ACP:OFFSet[n]:LIST[n]:BANDwidth|BWIDth
<res_bw>,<res_bw>,<res_bw>,<res_bw>,<res_bw>
```

```
[[:SENSe]:ACP:OFFSet[n]:LIST[n]:BANDwidth|BWIDth?
```

Define the custom resolution bandwidth(s) for the adjacent channel power testing. If there is more than one bandwidth, the list must contain five (5) entries. Each resolution bandwidth in the list corresponds to an offset frequency in the list defined by [:SENSe]:ACP:OFFSet[n]:LIST[n]:FREQuency]. You can turn off (not use) specific offsets with the [:SENSe]:ACP:OFFSet[n]:LIST[n]:STATe command.

Offset[n] n=1 is base station and 2 is mobiles. The default is base station (1).

List[n] n=1 is cellular bands and 2 is pcs bands. The default is cellular.

Factory Preset:

Mode	Variant	Offset A	Offset B	Offset C	Offset D	Offset E
iDEN (E4406A)		10 kHz	n/a	n/a	n/a	n/a
Basic (E4406A)		30 kHz	30 kHz	30 kHz	30 kHz	30 kHz
cdmaOne	BS cellular	30 kHz	30 kHz	30 kHz	30 kHz	30 kHz
	BS pcs	30 kHz	12.5 kHz	1 MHz	30 kHz	30 kHz
	MS cellular	30 kHz	30 kHz	30 kHz	30 kHz	30 kHz
	MS pcs	30 kHz	12.5 kHz	1 MHz	30 kHz	30 kHz
cdma2000		30 kHz	30 kHz	30 kHz	30 kHz	30 kHz
W-CDMA		3.84 MHz	3.84 MHz	3.84 MHz	3.84 MHz	3.84 MHz

Range: 300 Hz to 20 MHz for cdmaOne, Basic, cdma2000,

W-CDMA mode

1 kHz to 5 MHz for iDEN mode (E4406A)

Default Unit: Hz

Remarks: For PSA you must be in cdmaOne, cdma2000, or W-CDMA mode to use this command. Use INSTRUMENT:SELEct to set the mode.

For E4406A you must be in Basic, cdmaOne, cdma2000, W-CDMA, or iDEN mode to use this command. Use INSTRUMENT:SELEct to set the mode.

Adjacent Channel Power—FFT Segments

`[:SENSE] :ACP:OFFSet:LIST:FFTSegment
<integer>, <integer>, <integer>, <integer>, <integer>`

`[:SENSE] :ACP:OFFSet:LIST:FFTSegment?`

Selects the number of FFT segments used in making the measurement. In automatic mode the measurement optimizes the number of FFT segments required for the shortest measurement time. The minimum number of segments required to make a measurement is set by your desired measurement bandwidth. Selecting more than the minimum number of segments will give you more dynamic range for making the measurement, but the measurement will take longer to execute.

Factory Preset:

Mode	Offset A	Offset B	Offset C	Offset D	Offset E
Basic (E4406A)	1	1	1	1	1
cdmaOne	1	1	1	1	1

Range: 1 to 12

Remarks: You must be in Basic (E4406A), or cdmaOne mode to use this command. Use INSTRUMENT:SELEct to set the mode.

History: E4406A:
Revision A.03.00 or later, in cdmaOne revision A.04.00

Adjacent Channel Power—Automatic FFT Segments

`[:SENSE] :ACP:OFFSet:LIST:FFTSegment:AUTO OFF | ON | 0 | 1,
OFF | ON | 0 | 1, OFF | ON | 0 | 1, OFF | ON | 0 | 1, OFF | ON | 0 | 1`

`[:SENSe] :ACP:OFFSet:LIST:FFTSegment:AUTO?`

The automatic mode selects the optimum number of FFT segments to make the fastest possible measurement.

Factory Preset:

Mode	Offset A	Offset B	Offset C	Offset D	Offset E
Basic (E4406A)	ON	ON	ON	ON	ON
cdmaOne	ON	ON	ON	ON	ON

Remarks: You must be in Basic (E4406A), or cdmaOne mode to use this command. Use INSTRument:SElect to set the mode.

History: E4406A:
Revision A.03.00 or later

Adjacent Channel Power—Define Offset Frequency List

iDEN mode (E4406A)

`[:SENSe] :ACP:OFFSet [:FREQuency] <f_offset>`

`[:SENSe] :ACP:OFFSet [:FREQuency] ?`

Basic mode (E4406A)

`[:SENSe] :ACP:OFFSet:LIST [:FREQuency]
<f_offset>,<f_offset>,<f_offset>,<f_offset>,<f_offset>`

`[:SENSe] :ACP:OFFSet:LIST [:FREQuency] ?`

cdma2000, W-CDMA mode

`[:SENSe] :ACP:OFFSet [n] :LIST [:FREQuency]
<f_offset>,<f_offset>,<f_offset>,<f_offset>,<f_offset>`

`[:SENSe] :ACP:OFFSet [n] :LIST [:FREQuency] ?`

cdmaOne mode

`[:SENSe] :ACP:OFFSet [n] :LIST [n] [:FREQuency]
<f_offset>,<f_offset>,<f_offset>,<f_offset>,<f_offset>`

`[:SENSe] :ACP:OFFSet [n] :LIST [n] [:FREQuency] ?`

Define the custom set of offset frequencies at which the switching transient spectrum part of the ACP measurement will be made. The list contains five (5) entries for offset frequencies. Each offset frequency in the list corresponds to a reference bandwidth in the bandwidth list.

An offset frequency of zero turns the display of the measurement for

that offset off, but the measurement is still made and reported. You can turn off (not use) specific offsets with the [:SENSE]:ACP:OFFSet:LIST:STATe command.

Offset[n] n=1 is base station and 2 is mobiles. The default is base station (1).

List[n] n=1 is cellular bands and 2 is pcs bands. The default is cellular.

Factory Preset:

Mode	Variant	Offset A	Offset B	Offset C	Offset D	Offset E
iDEN (E4406A)		25 kHz	n/a	n/a	n/a	n/a
Basic (E4406A)		750 kHz	1.98 MHz	0 Hz	0 Hz	0 Hz
cdmaOne	BS cellular	750 kHz	1.98 MHz	0 Hz	0 Hz	0 Hz
	BS pcs	885 kHz	1.25625 MHz	2.75 MHz	0 Hz	0 Hz
	MS cellular	885 kHz	1.98 MHz	0 Hz	0 Hz	0 Hz
	MS pcs	1.265 MHz	0 Hz	0 Hz	0 Hz	0 Hz
cdma2000	BTS	750 kHz	1.98 MHz	0 Hz	0 Hz	0 Hz
	MS	885 kHz	1.98 MHz	0 Hz	0 Hz	0 Hz
W-CDMA		5 MHz	10 MHz	15 MHz	20 MHz	25 MHz

Range: 0 Hz to 45 MHz for cdmaOne
 0 Hz to 20 MHz for iDEN, Basic (E4406A)
 0 Hz to 100 MHz for cdma2000, W-CDMA

Default Unit: Hz

Remarks: For PSA you must be in cdmaOne, cdma2000, or W-CDMA mode to use this command. Use INSTRument:SElect to set the mode.

For E4406A you must be in Basic, cdmaOne, cdma2000, W-CDMA, or iDEN mode to use this command. Use INSTRument:SElect to set the mode.

Adjacent Channel Power—Number of Measured Points

[:SENSE]:ACP:OFFSet:LIST:POINTs
 <integer>,<integer>,<integer>,<integer>,<integer>

[:SENSE]:ACP:OFFSet:LIST:POINTs?

Selects the number of data points. The automatic mode chooses the optimum number of points for the fastest measurement time with acceptable repeatability. The minimum number of points that could be used is determined by the sweep time and the sampling rate. You can increase the length of the measured time record (capture more of the burst) by increasing the number of points, but the measurement will take longer. Use [:SENSe]:ACP:POINTs to set the number of points used for measuring the reference channel.

Factory Preset:

Mode	Offset A	Offset B	Offset C	Offset D	Offset E
Basic (E4406A)	1024	1024	1024	1024	1024
cdmaOne	1024	1024	1024	1024	1024

Range: 64 to 65536

Remarks: The fastest measurement times are obtained when the number of points measured is 2^n .

You must be in Basic (E4406A), or cdmaOne mode to use this command. Use INSTRument:SElect to set the mode.

History: E4406A:
Revision A.03.00 or later, in cdmaOne revision A.04.00

Adjacent Channel Power—Automatic Measurement Points

[:SENSe]:ACP:OFFSet:LIST:POINTs:AUTO OFF|ON|0|1,
OFF|ON|0|1, OFF|ON|0|1, OFF|ON|0|1, OFF|ON|0|1

[:SENSe]:ACP:OFFSet:LIST:POINTs:AUTO?

Automatically selects the number of points for the optimum measurement speed.

Factory Preset:

Mode	Offset A	Offset B	Offset C	Offset D	Offset E
Basic (E4406A)	ON	ON	ON	ON	ON
cdmaOne	ON	ON	ON	ON	ON

Remarks: You must be in Basic (E4406A), or cdmaOne mode to use this command. Use INSTRument:SElect to set the mode.

History: E4406A:
Revision A.03.00 or later, in cdmaOne revision A.04.00

Adjacent Channel Power—Relative Attenuation

```
[ :SENSE ] :ACP:OFFSet:LIST:RATTenuation
<rel_powr>,<rel_powr>,<rel_powr>,<rel_powr>,<rel_powr>
```

```
[ :SENSe ] :ACP:OFFSet:LIST:RATTenuation?
```

Sets a relative amount of attenuation for the measurements made at your offsets. The amount of attenuation is always specified relative to the attenuation that is required to measure the carrier channel. Since the offset channel power is lower than the carrier channel power, less attenuation is required to measure the offset channel and you get wider dynamic range for the measurement.

You can turn off (not use) specific offsets with the SENS:ACP:OFFSet:LIST:STATe command.

Factory Preset:

Mode	Offset A	Offset B	Offset C	Offset D	Offset E
Basic (E4406A)	0 dB	0 dB	0 dB	0 dB	0 dB
cdmaOne	0 dB	0 dB	0 dB	0 dB	0 dB

Range: -40 to 0 dB, but this relative attenuation cannot exceed the absolute attenuation range of 0 to 40 dB.

Default Unit: dB

Remarks: Remember that the attenuation that you specify is always relative to the amount of attenuation used for the carrier channel. Selecting negative attenuation means that you want less attenuation used. For example, if the measurement must use 20 dB of attenuation for the carrier measurement and you want to use 12 dB less attenuation for the first offset, you would send the value -12 dB.

You must be in Basic (E4406A), or cdmaOne mode to use this command. Use INSTRument:SElect to set the mode.

History: E4406A:
Revision A.03.00 or later, in cdmaOne revision A.04.00

Adjacent Channel Power—Relative Attenuation Control

```
[ :SENSe ] :ACP:OFFSet:LIST:RATTenuation:AUTO OFF|ON|0|1
```

```
[ :SENSe ] :ACP:OFFSet:LIST:RATTenuation:AUTO?
```

Automatically sets a relative attenuation to make measurements with the optimum dynamic range at the current carrier channel power.

You can turn off (not use) specific offsets with the SENS:ACP:OFFSet:LIST:STATe command.

Factory Preset: ON

Remarks: You must be in Basic (E4406A), or cdmaOne mode to use this command. Use INSTRument:SElect to set the mode.

History: E4406A:
Revision A.03.00 or later, in cdmaOne revision A.04.00.

Adjacent Channel Power—Amplitude Limits Relative to the Carrier

iDEN mode (E4406A)

```
[ :SENSe ] :ACP:OFFSet:RCARrier <rel_power>
```

```
[ :SENSe ] :ACP:OFFSet:RCARrier?
```

Basic mode (E4406A)

```
[ :SENSe ] :ACP:OFFSet:LIST:RCARrier  
<rel_power>,<rel_power>,<rel_power>,<rel_power>,<rel_power>
```

```
[ :SENSe ] :ACP:OFFSet:LIST:RCARrier?
```

cdma2000, W-CDMA mode

```
[ :SENSe ] :ACP:OFFSet [n] :LIST:RCARrier  
<rel_power>,<rel_power>,<rel_power>,<rel_power>,<rel_power>
```

```
[ :SENSe ] :ACP:OFFSet [n] :LIST:RCARrier?
```

cdmaOne mode

```
[ :SENSe ] :ACP:OFFSet [n] :LIST [n] :RCARrier  
<rel_power>,<rel_power>,<rel_power>,<rel_power>,<rel_power>
```

```
[ :SENSe ] :ACP:OFFSet [n] :LIST [n] :RCARrier?
```

Sets the amplitude levels to test against for any custom offsets. This amplitude level is relative to the carrier amplitude. If multiple offsets are available, the list contains five (5) entries. The offset closest to the carrier channel is the first one in the list.

[:SENSe] :ACP:OFFSet [n] :LIST [n] :TEST selects the type of testing to be done at each offset.

You can turn off (not use) specific offsets with the [:SENSE]:ACP:OFFSet[n]:LIST[n]:STATe command.

The query returns the five (5) sets of the real numbers that are the current amplitude test limits, relative to the carrier, for each offset.

Offset[n] n=1 is base station and 2 is mobiles. The default is base station (1).

List[n] n=1 is cellular bands and 2 is pcs bands. The default is cellular.

Factory Preset:

Mode	Variant	Offset A	Offset B	Offset C	Offset D	Offset E
iDEN (E4406A)		0 dBc	n/a	n/a	n/a	n/a
Basic (E4406A)		- 45 dBc	- 60 dBc	0 dBc	0 dBc	0 dBc
cdmaOne	BS cellular	- 45 dBc	- 60 dBc	0 dBc	0 dBc	0 dBc
	BS pcs	- 45 dBc	0 dBc	0 dBc	0 dBc	0 dBc
	MS cellular	- 42 dBc	- 54 dBc	0 dBc	0 dBc	0 dBc
	MS pcs	- 42 dBc	0 dBc	0 dBc	0 dBc	0 dBc
cdma2000		0 dBc	0 dBc	0 dBc	0 dBc	0 dBc
W-CDMA	BTS	- 44.2 dBc	- 49.2 dBc	- 49.2 dBc	- 49.2 dBc	- 49.2 dBc
	MS	- 32.2 dBc	- 42.2 dBc	- 42.2 dBc	- 42.2 dBc	- 42.2 dBc

Range: - 150.0 dB to 50.0 dB for cdmaOne, cdma2000, W-CDMA, Basic (E4406A)
 - 200.0 dB to 50.0 dB for iDEN (E4406A)

Default Unit: dB

Remarks: For PSA you must be in cdmaOne, cdma2000, or W-CDMA mode to use this command. Use INSTRument:SElect to set the mode.

For E4406A you must be in Basic, cdmaOne, cdma2000, W-CDMA, or iDEN mode to use this command. Use INSTRument:SElect to set the mode.

Adjacent Channel Power—Amplitude Limits Relative to the Power Spectral Density

iDEN mode (E4406A)

[:SENSE]:ACP:OFFSet:RPSDensity <rel_power>

```
[ :SENSe ] :ACP:OFFSet:RPSDensity?
```

Basic mode (E4406A)

```
[ :SENSe ] :ACP:OFFSet:LIST:RPSDensity  
<rel_power>,<rel_power>,<rel_power>,<rel_power>,<rel_power>
```

```
[ :SENSe ] :ACP:OFFSet:LIST:RPSDensity?
```

cdma2000, W-CDMA mode

```
[ :SENSe ] :ACP:OFFSet [n] :LIST:RPSDensity  
<rel_power>,<rel_power>,<rel_power>,<rel_power>,<rel_power>
```

```
[ :SENSe ] :ACP:OFFSet [n] :LIST:RPSDensity?
```

cdmaOne mode

```
[ :SENSe ] :ACP:OFFSet [n] :LIST [n] :RPSDensity  
<rel_power>,<rel_power>,<rel_power>,<rel_power>,<rel_power>
```

```
[ :SENSe ] :ACP:OFFSet [n] :LIST [n] :RPSDensity?
```

Sets the amplitude levels to test against for any custom offsets. This amplitude level is relative to the power spectral density. If multiple offsets are available, the list contains five (5) entries. The offset closest to the carrier channel is the first one in the list.

[:SENSe] :ACP:OFFSet [n] :LIST [n] :TEST selects the type of testing to be done at each offset.

You can turn off (not use) specific offsets with the [:SENSe] :ACP:OFFSet [n] :LIST:STATe command.

The query returns the five (5) sets of the real numbers that are the current amplitude test limits, relative to the power spectral density, for each offset.

Offset[n] n=1 is base station and 2 is mobiles. The default is base station (1).

List[n] n=1 is cellular bands and 2 is pcs bands. The default is cellular.

Factory Preset:

Mode	Variant	Offset A	Offset B	Offset C	Offset D	Offset E
iDEN (E4406A)		0 dB	n/a	n/a	n/a	n/a
Basic (E4406A)		-28.87 dB	-43.87 dB	0 dB	0 dB	0 dB

Mode	Variant	Offset A	Offset B	Offset C	Offset D	Offset E
cdmaOne	BS cellular	- 28.87 dB	- 43.87 dB	0 dB	0 dB	0 dB
	BS pcs	- 28.87 dB	0 dB	0 dB	0 dB	0 dB
	MS cellular	- 25.87 dB	- 37.87 dB	0 dB	0 dB	0 dB
	MS pcs	- 25.87 dB	0 dB	0 dB	0 dB	0 dB
cdma2000		0 dB	0 dB	0 dB	0 dB	0 dB
W-CDMA	BTS	- 44.2 dBc	- 49.2 dBc	- 49.2 dBc	- 49.2 dBc	- 49.2 dBc
	MS	- 32.2 dBc	- 42.2 dBc	- 42.2 dBc	- 42.2 dBc	- 42.2 dBc

Range: - 150.0 dB to 50.0 dB for cdmaOne, Basic, cdma2000, W-CDMA

- 200.0 dB to 50.0 dB for iDEN (E4406A)

Default Unit: dB

Remarks: For PSA you must be in cdmaOne, cdma2000, or W-CDMA mode to use this command. Use INSTRUMENT:SELEct to set the mode.

For E4406A you must be in Basic, cdmaOne, cdma2000, W-CDMA, or iDEN mode to use this command. Use INSTRUMENT:SELEct to set the mode.

Adjacent Channel Power—Select Sideband

`[:SENSE] :ACP:OFFSet:LIST:SIDE BOTH | NEGative | POSitive, BOTH | NEGative | POSitive, BOTH | NEGative | POSitive, BOTH | NEGative | POSitive`

`[:SENSe] :ACP:OFFSet:LIST:SIDE?`

Selects which sideband will be measured. You can turn off (not use) specific offsets with the SENS:ACP:OFFSet:LIST:STAtE command.

Factory Preset:

Mode	Offset A	Offset B	Offset C	Offset D	Offset E
Basic (E4406A)	BOTH	BOTH	BOTH	BOTH	BOTH
cdmaOne	BOTH	BOTH	BOTH	BOTH	BOTH

Remarks: You must be in Basic (E4406A), or cdmaOne mode to use this command. Use INSTRUMENT:SELEct to set the mode.

History: E4406A:
Revision A.03.00 or later, in cdmaOne revision A.04.00

Adjacent Channel Power—Control Offset Frequency List

Basic mode (E4406A)

```
[ :SENSe ] :ACP:OFFSet:LIST:STATe OFF|ON|0|1, OFF|ON|0|1,  
OFF|ON|0|1, OFF|ON|0|1, OFF|ON|0|1
```

```
[ :SENSe ] :ACP:OFFSet:LIST:STATe?
```

cdma2000, W-CDMA mode

```
[ :SENSe ] :ACP:OFFSet [n] :LIST:STATe OFF|ON|0|1, OFF|ON|0|1,  
OFF|ON|0|1, OFF|ON|0|1, OFF|ON|0|1
```

```
[ :SENSe ] :ACP:OFFSet [n] :LIST:STATe?
```

cdmaOne mode

```
[ :SENSe ] :ACP:OFFSet [n] :LIST [n] :STATe OFF|ON|0|1,  
OFF|ON|0|1, OFF|ON|0|1, OFF|ON|0|1, OFF|ON|0|1
```

```
[ :SENSe ] :ACP:OFFSet [n] :LIST [n] :STATe?
```

Selects whether testing is to be done at the custom offset frequencies. The measured powers are tested against the absolute values defined with [:SENSe]:ACP:OFFSet:LIST:ABSolute, or the relative values defined with [:SENSe]:ACP:OFFSet:LIST:RPSDensity and [:SENSe]:ACP:OFFSet:LIST:RCARier.

Offset[n] n=1 is base station and 2 is mobiles. The default is base station (1).

List[n] n=1 is cellular bands and 2 is pcs bands. The default is cellular.

Factory Preset:

Mode	Variant	Offset A	Offset B	Offset C	Offset D	Offset E
Basic (E4406A)		On	On	On	On	On
cdmaOne	BS cellular	On	On	On	On	On
	BS pcs	On	On	On	On	On
	MS cellular	On	On	On	On	On
	MS pcs	On	On	On	On	On
cdma2000		On	On	Off	Off	Off
W-CDMA		On	On	Off	Off	Off

Remarks: For PSA and E4406A you must be in Basic (E4406A), cdmaOne, cdma2000, or W-CDMA mode to use this command. Use INSTRument:SElect to set the mode.

Adjacent Channel Power—Sweep Time

[:SENSE] :ACP:OFFSet:LIST:SWEep:TIME
 <seconds>, <seconds>, <seconds>, <seconds>, <seconds>

[:SENSe] :ACP:OFFSet:LIST:SWEep:TIME?

Selects a specific sweep time. If you increase the sweep time, you increase the length of the time data captured and the number of points measured. You might need to specify a specific sweep speed to accommodate a specific condition in your transmitter. For example, you may have a burst signal and need to measure an exact portion of the burst.

Selecting a specific sweep time may result in a long measurement time since the resulting number of data points may not be the optimum 2^n . Use **[:SENSe] :ACP:SWEep:TIME** to set the number of points used for measuring the reference channel.

You can turn off (not use) specific offsets with the SENS:ACP:OFFSet:LIST:STATe command.

Factory Preset:

Mode	Offset A	Offset B	Offset C	Offset D	Offset E
Basic (E4406A)	11.20 ms	11.20 ms	11.20 ms	11.20 ms	11.20 ms
cdmaOne	11.20 ms	11.20 ms	11.20 ms	11.20 ms	11.20 ms

Range: 1 μ s to 50 ms

Default Unit: seconds

Remarks: You must be in Basic (E4406A), or cdmaOne mode to use this command. Use INSTRument:SElect to set the mode.

History: E4406A:
Revision A.03.00 or later, in cdmaOne revision A.04.00

Adjacent Channel Power—Automatic Sweep Time

[:SENSE] :ACP:OFFSet:LIST:SWEep:TIME:AUTO OFF | ON | 0 | 1,
OFF | ON | 0 | 1, OFF | ON | 0 | 1, OFF | ON | 0 | 1, OFF | ON | 0 | 1

[:SENSe] :ACP:OFFSet:LIST:SWEep:TIME:AUTO?

Sets the sweep time to be automatically coupled for the fastest measurement time. You can turn off (not use) specific offsets with the SENS:ACP:OFFSet:LIST:STATe command.

Factory Preset:

Mode	Offset A	Offset B	Offset C	Offset D	Offset E
Basic (E4406A)	On	On	On	On	On
cdmaOne	On	On	On	On	On

Remarks: You must be in Basic (E4406A), or cdmaOne mode to use this command. Use INSTRUMENT:SElect to set the mode.

History: E4406A:
Revision A.03.00 or later, in cdmaOne revision A.04.00

Adjacent Channel Power—Define Type of Offset Frequency List

iDEN mode (E4406A)

```
[ :SENSe ] :ACP:OFFSet:TEST ABSolute | AND | OR | RELative
```

```
[ :SENSe ] :ACP:OFFSet:TEST?
```

Basic mode (E4406A)

```
[ :SENSe ] :ACP:OFFSet:LIST:TEST ABSolute | AND | OR | RELative,  
ABSolute | AND | OR | RELative, ABSolute | AND | OR | RELative,  
ABSolute | AND | OR | RELative, ABSolute | AND | OR | RELative
```

```
[ :SENSe ] :ACP:OFFSet:LIST:TEST?
```

cdma2000, W-CDMA mode

```
[ :SENSe ] :ACP:OFFSet [n] :LIST:TEST ABSolute | AND | OR | RELative,  
ABSolute | AND | OR | RELative, ABSolute | AND | OR | RELative,  
ABSolute | AND | OR | RELative, ABSolute | AND | OR | RELative
```

```
[ :SENSe ] :ACP:OFFSet [n] :LIST:TEST?
```

cdmaOne mode

```
[ :SENSe ] :ACP:OFFSet [n] :LIST [n] :TEST,  
ABSolute | AND | OR | RELative,  
ABSolute | AND | OR | RELative, ABSolute | AND | OR | RELative,  
ABSolute | AND | OR | RELative
```

```
[ :SENSe ] :ACP:OFFSet [n] :LIST [n] :TEST?
```

Defines the type of testing to be done at any custom offset frequencies. The measured powers are tested against the absolute values defined

with [:SENSE]:ACP:OFFSet[n]:LIST:ABSolute, or the relative values defined with [:SENSE]:ACP:OFFSet:LIST:RPSDensity and [:SENSE]:ACP:OFFSet:LIST:RCARrier.

You can turn off (not use) specific offsets with the [:SENS]:ACP:OFFSet:LIST:STATe command.

Offset[n] n=1 is base station and 2 is mobiles. The default is base station (1).

List[n] n=1 is cellular bands and 2 is pcs bands. The default is cellular.

The types of testing that can be done for each offset include:

- Absolute - Test the absolute power measurement. If it fails, then return a failure for the measurement at this offset.
- And - Test both the absolute power measurement and the power relative to the carrier. If they both fail, then return a failure for the measurement at this offset.
- Or - Test both the absolute power measurement and the power relative to the carrier. If either one fails, then return a failure for the measurement at this offset.
- Relative - Test the power relative to the carrier. If it fails, then return a failure for the measurement at this offset.
- OFF - Turns the power test off.

Factory Preset:

Mode	Variant	Offset A	Offset B	Offset C	Offset D	Offset E
iDEN (E4406A)		REL	n/a	n/a	n/a	n/a
Basic (E4406A)		REL	REL	REL	REL	REL
cdmaOne	BS cellular	REL	REL	REL	REL	REL
	BS pcs	REL	ABS	ABS	REL	REL
	MS cellular	REL	REL	REL	REL	REL
	MS pcs	REL	ABS	ABS	REL	REL
cdma2000		REL	REL	REL	REL	REL
W-CDMA		REL	REL	REL	REL	REL

Remarks: For PSA you must be in cdmaOne, cdma2000, or W-CDMA mode to use this command. Use INSTRument:SElect to set the mode.

For E4406A you must be in Basic, cdmaOne, cdma2000, W-CDMA, or iDEN mode to use this command. Use

INSTRument:SElect to set the mode.

Adjacent Channel Power—Number of Measured Points

`[:SENSe] :ACP:POINts <integer>`

`[:SENSe] :ACP:POINts?`

Selects the number of data points used to measure the reference (carrier) channel. The automatic mode chooses the optimum number of points for the fastest measurement time with acceptable repeatability. The minimum number of points that could be used is determined by the sweep time and the sampling rate.

You can increase the length of the measured time record (capture more of the burst) by increasing the number of points, but the measurement will take longer. Use `[:SENSe] :ACP:OFFSet:LIST:POINts` to set the number of points used for measuring the offset channels.

Factory Preset: 1024

Remarks: The fastest measurement times are obtained when the number of points measured is 2^n .

You must be in Basic (E4406A), or cdmaOne mode to use this command. Use `INSTRument:SElect` to set the mode.

Range: 64 to 65536

History: E4406A:
Revision A.03.00 or later, in cdmaOne revision A.04.00

Adjacent Channel Power—Automatic Measurement Points

`[:SENSe] :ACP:POINts:AUTO OFF | ON | 0 | 1`

`[:SENSe] :ACP:POINts:AUTO?`

Automatically selects the number of points for the optimum measurement speed.

Factory Preset: ON

Remarks: You must be in Basic (E4406A), or cdmaOne mode to use this command. Use `INSTRument:SElect` to set the mode.

History: E4406A:
Revision A.03.00 or later, in cdmaOne revision A.04.00

Adjacent Channel Power—Spectrum Trace Control

`[:SENSE] :ACP:SPECTrum:ENABLE OFF | ON | 0 | 1`

`[:SENSe] :ACP:SPECTrum:ENABLE?`

Turns on/off the measurement of the spectrum trace data when the spectrum view is selected. (Select the view with `DISPlay:ACP:VIEW`.) You may want to disable the spectrum trace data part of the measurement so you can increase the speed of the rest of the measurement data.

Factory Preset: ON

Remarks: You must be in Basic (E4406A), cdmaOne, or iDEN (E4406A) mode to use this command. Use `INSTRument:SElect` to set the mode.

History: E4406A:
Revision A.03.27 or later, in cdmaOne revision A.04.00

Adjacent Channel Power—Sweep Mode Resolution Bandwidth

`[:SENSE] :ACP:SWEep:BANDwidth | BWIDth [:RESolution] <freq>`

`[:SENSe] :ACP:SWEep:BANDwidth | BWIDth [:RESolution] ?`

Sets the resolution bandwidth when using the spectrum analyzer type sweep mode. See `[:SENSE] :ACP:SWEep:TYPE`.

Factory Preset: Auto coupled.

Range: 1.0 kHz to 1.0 MHz

Resolution: 1.0 kHz

Step Size: 1.0 kHz

Default Unit: Hz

Remarks: You must be in the cdmaOne cdma2000, or W-CDMA mode to use this command. Use `INSTRument:SElect` to set the mode.

Adjacent Channel Power—Sweep Mode Resolution BW Control

`[:SENSE] :ACP:SWEep:BANDwidth | BWIDth [:RESolution] :AUTO
OFF | ON | 0 | 1`

`[:SENSe] :ACP:SWEep:BANDwidth | BWIDth [:RESolution] :AUTO?`

Sets the resolution bandwidth to automatic, when using the spectrum analyzer type sweep mode. See `[:SENSE] :ACP:SWEep:TYPE`.

Factory Preset: ON

Remarks: You must be in the cdmaOne cdma2000, or W-CDMA mode to use this command. Use INSTRument:SElect to set the mode.

Adjacent Channel Power—Sweep Time

`[:SENSe] :ACP :SWEep :TIME <seconds>`

`[:SENSe] :ACP :SWEep :TIME?`

Selects a specific sweep time used to measure the reference (carrier) channel. If you increase the sweep time, you increase the length of the time data captured and the number of points measured. You might need to specify a specific sweep speed to accommodate a specific condition in your transmitter. For example, you may have a burst signal and need to measure an exact portion of the burst.

Selecting a specific sweep time may result in a long measurement time since the resulting number of data points may not be the optimum 2^n . Use `[:SENSe] :ACP :OFFSet :LIST :SWEep :TIME` to set the number of points used for measuring the offset channels for Basic and cdmaOne.

For cdma2000 and W-CDMA, this command sets the sweep time when using the sweep mode. See `[:SENSe] :ACP :SWEep :TYPE`.

Factory Preset: 625 μ s (1 slot) for W-CDMA

1.25 ms for cdma2000

11.20 ms for Basic, cdmaOne

Range: 500 μ s to 10 ms for W-CDMA, cdma2000

1 μ s to 50 ms for Basic (E4406A), cdmaOne

Default Unit: seconds

Remarks: You must be in the Basic (E4406A), cdmaOne, cdma2000, or W-CDMA mode to use this command. Use INSTRument:SElect to set the mode.

History: E4406A:
Added to Basic revision A.03.00, to cdmaOne revision A.04.00

Adjacent Channel Power—Automatic Sweep Time

`[:SENSe] :ACP :SWEep :TIME :AUTO OFF | ON | 0 | 1`

`[:SENSe] :ACP :SWEep :TIME :AUTO?`

Sets the sweep time to be automatically coupled for the fastest measurement time.

Factory Preset: ON

Remarks: You must be in Basic (E4406A), or cdmaOne mode to use this command. Use INSTRUMENT:SELEct to set the mode.

History: E4406A:
Revision A.03.00 or later, in cdmaOne revision A.04.00

Adjacent Channel Power—Trigger Source

```
[ :SENSE ] :ACP:TRIGger:SOURce
EXTernal [1] | EXTernal2 | FRAMe | IF | IMMEDIATE | RFBURSt
[ :SENSE ] :ACP:TRIGger:SOURce?
```

Select the trigger source used to control the data acquisitions.

EXTernal 1 – front panel external trigger input

EXTernal 2 – rear panel external trigger input

FRAMe – internal frame trigger from front panel input

IF – internal IF envelope (video) trigger

IMMEDIATE – the next data acquisition is immediately taken, capturing the signal asynchronously (also called free run).

RFBURSt – wideband RF burst envelope trigger that has automatic level control for periodic burst signals.

Factory Preset: IMMEDIATE for BS

RFBURSt for MS

Remarks: For PSA you must be in cdmaOne, NADC, or PDC mode to use this command. Use INSTRUMENT:SELEct to set the mode.

For E4406A you must be in Basic, cdmaOne, iDEN, NADC, or PDC mode to use this command. Use INSTRUMENT:SELEct to set the mode.

In Basic mode, for offset frequencies >12.5 MHz, the external triggers will be a more reliable trigger source than RF burst. Also, you can use the Waveform measurement to set up trigger delay.

History: E4406A:
Added revision A.04.00 or later

Adjacent Channel Power—Power Reference

`[:SENSe] :ACP:TYPE PSDRef | TPRef`

`[:SENSe] :ACP:TYPE?`

Selects the measurement type. This allows you to make absolute and relative power measurements of either total power or the power normalized to the measurement bandwidth.

Power Spectral Density Reference (PSDRef) - the power spectral density is used as the power reference

Total Power Reference (TPRef) - the total power is used as the power reference

Factory Preset: Total power reference (TPRef)

Remarks:

For E4406A you must be in the Basic, cdmaOne, cdma2000, W-CDMA, NADC, or PDC mode to use this command. Use `INSTRument:SElect` to set the mode.

For PSA you must be in the cdmaOne, cdma2000, W-CDMA, NADC, or PDC mode to use this command. Use `INSTRument:SElect` to set the mode.

Baseband I/Q Commands (E4406A only)

Baseband I/Q - Select I/Q Power Range

`[:SENSE] :POWER:IQ:RANGE [:UPPER] <power> [DBM] | DBMV | W`

`[:SENSE] :POWER:IQ:RANGE [:UPPER] ?`

Selects maximum total power expected from unit under test at test port when I or Q port is selected.

Range: For 50 Ohms:
 13.0, 7.0, 1.0, or - 5.1 dBm
 60.0, 54.0, 48.0, or 41.9 dBmV
 0.02, 0.005, 0.0013, or 0.00031 W

For 600 Ohms:
 2.2, - 3.8, - 9.8, or - 15.8 dBm
 60.0, 54.0, 48.0, or 41.9 dBmV
 0.0017, 0.00042, 0.0001, or 0.000026 W

For 1 M Ohm:
 Values for 1 M Ohm vary according to selected
 reference impedance.

Default Units: DBM

Remarks: You must be in the Basic, W-CDMA, cdma2000 mode to use this command. Use INSTRUMENT:SELEct to set the mode.

History: Added revision A.05.00

Baseband I/Q - Select I/Q Voltage Range

`[:SENSE] :VOLTage:IQ:RANGE [:UPPER] <level>`

`[:SENSE] :VOLTage:IQ:RANGE [:UPPER] ?`

Selects upper voltage range when I or Q port is selected. This setting helps set the gain which is generated in the variable gain block of the baseband IQ board to improve dynamic range.

Range: 1.0, 0.5, .025, or 0.125 volts

Default Units: V

Remarks: You must be in the Basic, W-CDMA, cdma2000 mode to use this command. Use INSTRUMENT:SELEct to set the mode.

History: Added revision A.05.00

Code Domain Measurement

Commands for querying the code domain power measurement results and for setting to the default values are found in the “[MEASure Group of Commands](#)” on page 213. The equivalent front panel keys for the parameters described in the following commands, are found under the **Meas Setup** key, after the **Code Domain** measurement has been selected from the **MEASURE** key menu.

Code Domain—Average Count

```
[ :SENSe ] :CDPower:AVERAge:COUNT <integer>
```

```
[ :SENSe ] :CDPower:AVERAge:COUNT?
```

Set the number of frames that will be averaged. After the specified number of frames (average counts) have been averaged, the averaging mode (termination control) setting determines the averaging action.

Factory Preset: 10

Range: 1 to 10,000

Remarks: You must be in the cdmaOne mode to use this command. Use INSTRument:SElect to set the mode.

Code Domain—Averaging State

```
[ :SENSe ] :CDPower:AVERAge[:STATe] OFF|ON|0|1
```

```
[ :SENSe ] :CDPower:AVERAge[:STATe]?
```

Turn code domain power averaging on or off.

Factory Preset: ON

Remarks: You must be in the cdmaOne mode to use this command. Use INSTRument:SElect to set the mode.

Code Domain—Averaging Termination Control

```
[ :SENSe ] :CDPower:AVERAge:TCONTRol EXPonential|REPeat
```

```
[ :SENSe ] :CDPower:AVERAge:TCONTRol?
```

Select the type of termination control used for averaging. This determines the averaging action after the specified number of frames (average count) is reached.

EXPonential - Each successive data acquisition after the average count is reached, is exponentially weighted and combined with the existing average.

REPeat - After reaching the average count, the averaging is reset

and a new average is started.

Factory Preset: REPeat

Remarks: You must be in the cdmaOne mode to use this command. Use INSTRument:SElect to set the mode.

Code Domain—Active Set Threshold

```
[ :SENSE ] :CDPower:ASET:THReshold <rel_power>
```

```
[ :SENSE ] :CDPower:ASET:THReshold?
```

Set the active set threshold value. Walsh channels with power less than this value, will be treated as non-active (noise) channels.

Factory Preset: – 20 dB

Range: – 30 dB to 0 dB

Default Unit: dB

Remarks: You must be in the cdmaOne mode to use this command. Use INSTRument:SElect to set the mode.

Code Domain—Method

```
[ :SENSE ] :CDPower:METHod FPOWER | POWER | TPHase
```

```
[ :SENSE ] :CDPower:METHod?
```

Select the measurement method.

- Fast Power (FPOWER)- Provides the fastest code domain power measurement. Only measures the power of those Walsh channels with powers greater than the active set threshold level.
- POWER - Measures the code domain power of all 64 Walsh Channels.
- Timing & Phase (TPHase)- Measures the code domain power, code domain timing, and code domain phase of all 64 Walsh channels.

Factory Preset: FPOWER

Remarks You must be in the cdmaOne mode to use this command. Use INSTRument:SElect to set the mode.

Code Domain—Spectrum Normal/Invert

```
[ :SENSE ] :CDPower:SPECTrum INVert | NORMAl
```

```
[ :SENSE ] :CDPower:SPECTrum?
```

Set a spectrum either to normal or inverted for the demodulation

related measurements. If set to INVert, the upper and lower spectrums are swapped.

Factory Preset: NORMal

Remarks You must be in the cdmaOne, cdma2000, W-CDMA, or 1xEV-DO mode to use this command. Use INSTRument:SElect to set the mode.

Code Domain—Measurement Interval

[[:SENSe]:CDPower:SWEep:TIME <time>

[[:SENSe]:CDPower:SWEep:TIME?

Set the length of the measurement interval that will be used.

Factory Preset: 1.250 ms

Range: 0.5 ms to 30 ms

Default Unit: seconds

Remarks: You must be in the cdmaOne mode to use this command. Use INSTRument:SElect to set the mode.

Channel Commands

Digital Demod PN Offset

[[:SENSe]:CHANnel:PNOffset <integer>

[[:SENSe]:CHANnel:PNOffset?

Set the PN offset number for the base station being tested.

Factory Preset: 0

Range: 0 to 511

Default Unit: None

Remarks: Global to the current mode.

You must be in the cdmaOne mode to use this command. Use INSTRument:SElect to set the mode.

Front Panel

Access: **FREQUENCY Channel, PN Offset**

or

Mode Setup, Demod, PN Offset

Channel Power Measurement

Commands for querying the channel power measurement results and for setting to the default values are found in the “[MEASure Group of Commands](#)” on page 213. The equivalent front panel keys for the parameters described in the following commands, are found under the **Meas Setup** key, after the **Channel Power** measurement has been selected from the **MEASURE** key menu.

Channel Power—Average Count

```
[ :SENSE ] :CHPower:AVERage:COUNT <integer>
```

```
[ :SENSE ] :CHPower:AVERage:COUNT?
```

Set the number of data acquisitions that will be averaged. After the specified number of average counts, the averaging mode (terminal control) setting determines the averaging action.

Factory Preset: 20

200, for W-CDMA

Range: 1 to 10,000

Remarks: For PSA you must be in the cdmaOne, cdma2000, W-CDMA, or 1xEV-DO mode to use this command. Use INSTRument:SElect to set the mode.

For E4406A you must be in the Basic, cdmaOne, cdma2000, W-CDMA, or 1xEV-DO mode to use this command. Use INSTRument:SElect to set the mode.

Channel Power—Averaging State

```
[ :SENSE ] :CHPower:AVERage [:STATe] OFF | ON | 0 | 1
```

```
[ :SENSE ] :CHPower:AVERage [:STATe] ?
```

Turn averaging on or off.

Factory Preset: ON

Remarks: For PSA you must be in the cdmaOne, cdma2000, W-CDMA, or 1xEV-DO mode to use this command. Use INSTRument:SElect to set the mode.

For E4406A you must be in the Basic, cdmaOne, cdma2000, W-CDMA, or 1xEV-DO mode to use this command. Use INSTRument:SElect to set the mode.

Channel Power—Averaging Termination Control

```
[ :SENSe ] :CHPower:AVERage:TCONtrol EXPonential | REPEAT
```

```
[ :SENSe ] :CHPower:AVERage:TCONtrol?
```

Select the type of termination control used for the averaging function. This determines the averaging action after the specified number of data acquisitions (average count) is reached.

EXPonential - Each successive data acquisition after the average count is reached, is exponentially weighted and combined with the existing average.

REPEAT - After reaching the average count, the averaging is reset and a new average is started.

Factory Preset: REPEAT

Remarks: For PSA you must be in the cdmaOne, cdma2000, W-CDMA, or 1xEV-DO mode to use this command. Use INSTRument:SElect to set the mode.

For E4406A you must be in the Basic, cdmaOne, cdma2000, W-CDMA, or 1xEV-DO mode to use this command. Use INSTRument:SElect to set the mode.

Channel Power—Integration BW

```
[ :SENSe ] :CHPower:BANDwidth | BWIDth:INTEgration <freq>
```

```
[ :SENSe ] :CHPower:BANDwidth | BWIDth:INTEgration?
```

Set the Integration BW (IBW) that will be used.

Factory Preset: 1.23 MHz for Basic (E4406A), cdmaOne, cdma2000, 1xEV-DO

5.0 MHz for W-CDMA

Range: 1 kHz to 10 MHz

Default Unit: Hz

Remarks: For PSA you must be in the cdmaOne, cdma2000, W-CDMA, or 1xEV-DO mode to use this command. Use INSTRument:SElect to set the mode.

For E4406A you must be in the Basic, cdmaOne, cdma2000, W-CDMA, or 1xEV-DO mode to use this command. Use INSTRument:SElect to set the mode.

Channel Power—Span

`[:SENSE] :CHPower:FREQUENCY:SPAN <freq>`

`[:SENSE] :CHPower:FREQUENCY:SPAN?`

Set the frequency span that will be used.

Factory Preset: 2.0 MHz for Basic, cdmaOne, cdma2000, 1xEV-DO
6.0 MHz for W-CDMA

Range: Dependent on the current setting of the channel power integration bandwidth

Default Unit: Hz

Remarks: For PSA you must be in the cdmaOne, cdma2000, W-CDMA, or 1xEV-DO mode to use this command. Use INSTRUMENT:SELEct to set the mode.

For E4406A you must be in the Basic, cdmaOne, cdma2000, W-CDMA, or 1xEV-DO mode to use this command. Use INSTRUMENT:SELEct to set the mode.

Channel Power—Data Points

`[:SENSE] :CHPower:POINTs <integer>`

`[:SENSE] :CHPower:POINTs?`

Set the number of data points that will be used. Changing this will change the time record length and resolution BW that are used.

Factory Preset: 512

Range: 64 to 32768, in a 2ⁿ sequence

Remarks: For PSA you must be in the cdmaOne, cdma2000, W-CDMA, or 1xEV-DO mode to use this command. Use INSTRUMENT:SELEct to set the mode.

For E4406A you must be in the Basic, cdmaOne, cdma2000, W-CDMA, or 1xEV-DO mode to use this command. Use INSTRUMENT:SELEct to set the mode.

Channel Power—Data Points Auto

`[:SENSE] :CHPower:POINTs:AUTO OFF|ON|0|1`

`[:SENSE] :CHPower:POINTs:AUTO?`

Select auto or manual control of the data points. This is an advanced control that normally does not need to be changed. Setting this to a value other than the factory default, may cause invalid measurement

results.

OFF - the Data Points is uncoupled from the Integration BW.

ON - couples the Data Points to the Integration BW.

Factory Preset: ON

Remarks: You must be in the Basic (E4406A), cdmaOne, cdma2000, W-CDMA, 1xEV-DO mode to use this command. Use INSTRument:SElect to set the mode.

Channel Power—Sweep Time

```
[ :SENSe ] :CHPower:SWEep:TIME <time>
```

```
[ :SENSe ] :CHPower:SWEep:TIME?
```

Sets the sweep time when using the sweep mode.

Factory Preset: 68.27 μ s

17.07 μ s for W-CDMA

Range: 1 μ s to 50 ms

Default Unit: seconds

Remarks: You must be in the Basic (E4406A), cdmaOne, cdma2000, W-CDMA, or 1xEV-DO mode to use this command. Use INSTRument:SElect to set the mode.

History: E4406A:
Version A.03.00 and later

Channel Power—Sweep Time

```
[ :SENSe ] :CHPower:SWEep:TIME:AUTO OFF|ON|0|1
```

```
[ :SENSe ] :CHPower:SWEep:TIME:AUTO?
```

Selects the automatic sweep time, optimizing the measurement.

Factory Preset: ON

Remarks: You must be in the Basic (E4406A), cdmaOne, cdma2000, W-CDMA, or 1xEV-DO mode to use this command. Use INSTRument:SElect to set the mode.

History: E4406A:
Version A.03.00 and later

Channel Power—Trigger Source

```
[ :SENSe ] :CHPower:TRIGger:SOURce  
EXTernal [1] | EXTernal2 | IMMEDIATE
```

```
[ :SENSe ] :CHPower:TRIGger:SOURce?
```

Select the trigger source used to control the data acquisitions. This is an Advanced control that normally does not need to be changed.

EXTernal 1 - front panel external trigger input

EXTernal 2 - rear panel external trigger input

IMMEDIATE - the next data acquisition is immediately taken (also called Free Run).

Factory Preset: IMMEDIATE

Remarks: For PSA you must be in the cdmaOne, cdma2000, W-CDMA, or 1xEV-DO mode to use this command. Use INSTRUMENT:SELEct to set the mode.

For E4406A you must be in the Basic, cdmaOne, cdma2000, W-CDMA, or 1xEV-DO mode to use this command. Use INSTRUMENT:SELEct to set the mode.

Signal Corrections Commands

Correction for Base Station RF Port External Attenuation

`[:SENSe] :CORRection:BS [:RF] :LOSS <rel_power>`

`[:SENSe] :CORRection:BS [:RF] :LOSS?`

Set the correction equal to the external attenuation used when measuring base stations.

Factory Preset: 0 dB

Range: – 50 to 100 dB for cdmaOne, iDEN (E4406A)
 – 50 to 50 dB for NADC or PDC

Default Unit: dB

Remarks: You must be in the iDEN (E4406A), cdmaOne, NADC or PDC mode to use this command. Use `INSTRument:SElect` to set the mode.

Value is global to the current mode.

Correction for MS RF Port External Attenuation

`[:SENSe] :CORRection:MS [:RF] :LOSS <rel_power>`

`[:SENSe] :CORRection:MS [:RF] :LOSS?`

Set the correction equal to the external attenuation used when measuring mobile stations.

Factory Preset: 0.0 dB

Range: – 50 to 100.0 dB for cdmaOne, GSM, EDGE, iDEN
 – 100.0 to 100.0 dB for cdma2000, W-CDMA, 1xEV-DO
 – 50.0 to 50.0 dB for NADC, PDC

Default Unit: dB

Remarks: For E4406A you must be in the cdmaOne, GSM, EDGE (w/GSM), cdma2000, W-CDMA, iDEN, NADC, PDC, or 1xEV-DO mode to use this command. Use `INSTRument:SElect` to set the mode.

For PSA you must be in the cdmaOne, GSM (w/EDGE), cdma2000, W-CDMA, NADC, PDC, or 1xEV-DO mode to use this command. Use `INSTRument:SElect` to set the mode.

Value is global to the current mode.

Spur Close—Measurement

Commands for querying the close spurs measurement results and for setting to the default values are found in the “[MEASure Group of Commands](#)” on page 213. The equivalent front panel keys for the parameters described in the following commands, are found under the **Meas Setup** key, after the **Spur Close** measurement has been selected from the **MEASURE** key menu.

Spur Close—Average Count

```
[ :SENSE ] : CSPur : AVERAge : COUNT <integer>
```

```
[ :SENSE ] : CSPur : AVERAge : COUNT ?
```

Set the number of data acquisitions that will be averaged. After the specified number of average counts, the averaging mode (terminal control) setting determines the averaging action.

Factory Preset: 15

Range: 1 to 10,000

Remarks: You must be in the cdmaOne mode to use this command. Use INSTRument:SElect to set the mode.

Front Panel

Access: **Meas Setup**

Spur Close—Averaging State

```
[ :SENSE ] : CSPur : AVERAge [ :STATe ] OFF | ON | 0 | 1
```

```
[ :SENSE ] : CSPur : AVERAge [ :STATe ] ?
```

Turn averaging on or off.

Factory Preset: ON

Remarks: You must be in the cdmaOne mode to use this command. Use INSTRument:SElect to set the mode.

Front Panel

Access: **Meas Setup**

Spur Close—Averaging Termination Control

```
[ :SENSE ] : CSPur : AVERAge : TCONtrol EXPonential | REPEAT
```

```
[ :SENSE ] : CSPur : AVERAge : TCONtrol ?
```

Select the type of termination control used for the averaging function. This determines the averaging action after the specified number of data acquisitions (average count) is reached.

EXPOnential - Each successive data acquisition after the average count is reached, is exponentially weighted and combined with the existing average.

REPeat - After reaching the average count, the averaging is reset and a new average is started.

Factory Preset: REPeat

Remarks: You must be in the cdmaOne mode to use this command. Use INSTRument:SElect to set the mode.

Front Panel

Access: **Meas Setup**

Spur Close—Averaging Type

[:SENSe] :CSPur :AVERAge :TYPE LOG | MAXimum | RMS | SCALar

[:SENSe] :CSPur :AVERAge :TYPE?

Select the type of averaging.

LOG - The log of the power is averaged. (This is also known as video averaging.)

MAXimum - The maximum values are retained.

RMS - The power is averaged, providing the rms of the voltage.

SCALar - The voltage is averaged.

Factory Preset: RMS

Remarks: You must be in the cdmaOne mode to use this command. Use INSTRument:SElect to set the mode.

Spur Close—Type

[:SENSe] :CSPur :TYPE EXAMine | FULL

[:SENSe] :CSPur :TYPE?

Select the measurement type.

EXAMine - measures spurs in the upper, lower, and center segments and then displays the worst spur

FULL - continuously measures the spurs in the upper, lower, and center segments

Factory Preset: FULL

Remarks: You must be in the cdmaOne mode to use this command. Use INSTRument:SElect to set the mode.

Front Panel

Access: **Meas Setup, Advanced (E4406A)**

RF Input Signal Alignments

Select the Input Signal

(PSA)

```
[ :SENSe ] :FEED RF | AREFereNce | IFAligN
```

(E4406A)

```
[ :SENSe ] :FEED RF | IQ | IONLy | QONLy | AREFereNce | IFAligN
```

```
[ :SENSe ] :FEED?
```

Selects the input signal. The default input signal is taken from the front panel RF input port. For calibration and testing purposes the input signal can be taken from an internal 321.4 MHz IF alignment signal or an internal 50 MHz amplitude reference source.

For E4406A if the baseband IQ option (Option B7C) is installed, I and Q input ports are added to the front panel. The I and Q ports accept the in-phase and quadrature components of the IQ signal, respectively. The input signal can be taken from either or both ports.

RF selects the signal from the front panel RF INPUT port.

IQ selects the combined signals from the front panel optional I and Q input ports. (E4406A with Option B7C in Basic, W-CDMA, cdma2000, EDGE(w/GSM) modes)

IONLy selects the signal from the front panel optional I input port. (E4406A with Option B7C in Basic mode)

QONLy selects the signal from the front panel optional Q input port. (E4406A with Option B7C in Basic mode)

AREFereNce selects the internal 50 MHz amplitude reference signal.

IFAligN selects the internal, 321.4 MHz, IF alignment signal.

Factory Preset: RF

Front Panel

Access: **Input, Input Port**

History: E4406A:
modified in version A.05.00

RF Power Commands

RF Port Input Attenuation

```
[ :SENSe] :POWER [:RF] :ATTenuation <rel_power>
```

```
[ :SENSe] :POWER [:RF] :ATTenuation?
```

Set the RF input attenuator. This value is set at its auto value if RF input attenuation is set to auto.

Factory Preset: 0 dB

12 dB for iDEN (E4406A)

Range: 0 to 40 dB

Default Unit: dB

Front Panel

Access: **Input, Input Atten**

RF Port Power Range Auto

```
[ :SENSe] :POWER [:RF] :RANGe:AUTO OFF|ON|0|1
```

```
[ :SENSe] :POWER [:RF] :RANGe:AUTO?
```

Select the RF port power range to be set either automatically or manually.

ON - power range is automatically set as determined by the actual measured power level at the start of a measurement.

OFF - power range is manually set

Factory Preset: ON

Remarks: You must be in the cdmaOne, GSM, EDGE, NADC, PDC, cdma2000, W-CDMA, mode to use this command. Use INSTRument:SElect to set the mode.

Front Panel

Access: **Input, Max Total Pwr (at UUT)**

RF Port Power Range Maximum Total Power

```
[ :SENSe] :POWER [:RF] :RANGe [:UPPer] <power>
```

```
[ :SENSe] :POWER [:RF] :RANGe [:UPPer] ?
```

Set the maximum expected total power level at the radio unit under test. This value is ignored if RF port power range is set to auto. External attenuation required above 30 dBm.

Programming Commands
SENSe Subsystem

Factory Preset: – 15.0 dBm

Range: – 100.0 to 80.0 dBm for EDGE, GSM
– 100.0 to 27.7 dBm for cdmaOne, iDEN (E4406A)
– 200.0 to 50.0 dBm for NADC, PDC
– 200.0 to 100.0 dBm for cdma2000, W-CDMA

Default Unit: dBm

Remarks: Global to the current mode. This is coupled to the RF input attenuation

For E4406A you must be in the Service, cdmaOne, EDGE(w/GSM), GSM, iDEN, NADC, PDC, cdma2000, or W-CDMA mode to use this command. Use INSTRument:SElect to set the mode.

For PSA you must be in the cdmaOne, GSM, EDGE, NADC, PDC, cdma2000, or W-CDMA mode to use this command. Use INSTRument:SElect to set the mode.

Front Panel

Access: **Input, Max Total Pwr (at UUT)**

Radio Standards Commands

Radio Carrier Multiple

```
[ :SENSE ] :RADio:CARRier:NUMBER SINGLE | MULTiple
```

```
[ :SENSE ] :RADio:CARRier:NUMBER?
```

Select if single or multiple carriers are present on the output of the base station under test. This enables/disables a software filter for the rho and code domain power measurements.

SINGLE – disable software filter.

MULTiple – enable software filter to mitigate the adjacent carrier effects.

Factory Preset: SINGLE

Remarks: You must be in the cdmaOne, cdma2000, 1xEV-DO, or iDEN (E4406A) mode to use this command. Use INSTRUMENT:SELEct to set the mode.

Front Panel

Access: **Mode Setup, Demod, RF Carrier**

Radio Device Under Test

```
[ :SENSE ] :RADio:DEVIce BS | MS
```

```
[ :SENSE ] :RADio:DEVIce?
```

Select the type of radio device to be tested.

BS – Base station transceiver test

MS – Mobile station transceiver test

Factory Preset: BS

Remarks: You must be in the NADC, or PDC mode to use this command. Use INSTRUMENT:SELEct to set the mode.

Global to current mode.

Front Panel

Access: **Mode Setup, Radio, Device**

Radio Standard Band

```
[ :SENSE ] :RADio:STANdard:BAND IS95A | JSTD8 | IS97D
```

```
[ :SENSE ] :RADio:STANdard:BAND?
```

Select the standard variant that applies to the radio to be tested.

IS95A - IS-95A Cellular

IS97D - IS-97D Cellular

JSTD8 - J-STD-008 PCS

Factory Preset: IS-95A Cellular

Remarks: Global to the current mode.

You must be in the cdmaOne mode to use this command. Use INSTRument:SElect to set the mode.

Front Panel

Access: **Mode Setup, Radio, Band**

Radio Standard Band

[[:SENSe]:RADio:STANdard:BAND:CLASs BC0|BC1|BC3|BC4

[[:SENSe]:RADio:STANdard:BAND:CLASs?

Select the band class (for IS-97D/98D) that applies to the radio to be tested.

BC0 - Band Class 0 (800 MHz Band [North American & Korean Cellular band])

BC1 - Band Class 1 (1900 MHz Band [North American PCS band])

BC3 - Band Class 3 (JTACS Band [Japan TACS band])

BC4 - Band Class 4 (Korean PCS band)

Factory Preset: BC0

Remarks: Global to the current mode.

You must be in the cdmaOne mode to use this command. Use INSTRument:SElect to set the mode.

Front Panel

Access: **Mode Setup, Radio, Standard/Band**

Mode Setup, Radio, Band

Modulation Accuracy (Rho) Measurement

Commands for querying the rho measurement results and for setting to the default values are found in the [“MEASure Group of Commands” on page 213](#). The equivalent front panel keys for the parameters described in the following commands, are found under the **Meas Setup** key, after the **Mod Accuracy (Rho)** or **Mod Accuracy (Composite Rho)** measurement has been selected from the **MEASURE** key menu.

Modulation Accuracy (Rho)—Average Count

`[:SENSE] :RHO:AVERAge:COUNT <integer>`

`[:SENSE] :RHO:AVERAge:COUNT?`

Set the number of data acquisitions that will be averaged. After the specified number of averaging counts, the averaging mode (termination control) setting determines the averaging action.

Factory Preset: 10

Range: 1 to 10,000

Remarks: You must be in the cdmaOne, cdma2000, W-CDMA, or 1xEV-DO mode to use this command. Use INSTRUMENT:SELEct to set the mode.

Modulation Accuracy (Rho)—Averaging State

`[:SENSE] :RHO:AVERAge [:STATe] OFF | ON | 0 | 1`

`[:SENSE] :RHO:AVERAge [:STATe] ?`

Turn the modulation accuracy averaging function on or off.

Factory Preset: OFF

ON for cdma2000, W-CDMA, 1xEV-DO

Remarks: You must be in the cdmaOne, cdma2000, W-CDMA, or 1xEV-DO mode to use this command. Use INSTRUMENT:SELEct to set the mode.

Modulation Accuracy (Rho)—Averaging Termination Control

`[:SENSE] :RHO:AVERAge:TCONtrol EXPonential | REPEAT`

`[:SENSE] :RHO:AVERAge:TCONtrol?`

Select the type of termination control used for the averaging function. This determines the averaging action after the specified number of frames (average count) is reached.

EXPonential - Each successive data acquisition after the average count is reached, is exponentially weighted and combined with the existing average.

REPEAT - After reaching the average count, the averaging is reset and a new average is started.

Factory Preset: REPEAT for cdmaOne, cdma2000, W-CDMA, 1xEV-DO

Remarks: You must be in the cdmaOne, cdma2000, W-CDMA, or 1xEV-DO mode to use this command. Use INSTRument:SElect to set the mode.

Modulation Accuracy (Rho)—Spectrum Normal/Invert

```
[ :SENSe ] :RHO:SPECTrum INVert | NORMAl
```

```
[ :SENSe ] :RHO:SPECTrum?
```

Set a spectrum either to normal or inverted for the demodulation related measurements. If set to INVert, the upper and lower spectrums are swapped.

Factory Preset: NORMAl

Remarks You must be in the cdmaOne, cdma2000, W-CDMA, or 1xEV-DO mode to use this command. Use INSTRument:SElect to set the mode.

Modulation Accuracy (Rho)—Sweep Time (Measurement Interval)

```
[ :SENSe ] :RHO:SWEep:TIME <time>
```

```
[ :SENSe ] :RHO:SWEep:TIME?
```

Set the length of the measurement interval that will be used.

Factory Preset: 1.250 ms

Range: 0.5 ms to 30 ms

Default Unit: seconds

Remarks: You must be in the cdmaOne mode to use this command. Use INSTRument:SElect to set the mode.

Modulation Accuracy (Rho)—Trigger Source

```
[ :SENSe ] :RHO:TRIGger:SOURce  
EXTernal [1] | EXTernal2 | FRAMe | IF | IMMEDIATE | RFBurst
```

```
[ :SENSe ] :RHO:TRIGger:SOURce?
```

Select the trigger source used to control the data acquisitions.

EXTernal 1 – front panel external trigger input

EXTernal 2 – rear panel external trigger input

FRAMe – internal frame trigger

IF – internal IF envelope (video) trigger

IMMEDIATE – the next data acquisition is immediately taken, capturing the signal asynchronously (also called free run).

RFBURST – internal wideband RF burst envelope trigger that has automatic level control for periodic burst signals.

Factory Preset: IMMEDIATE

Remarks: You must be in the cdmaOne, cdma2000, W-CDMA, or 1xEV-DO mode to use this command. Use INSTRUMENT:SELECT to set the mode.

Front Panel

Access: **Meas Setup, Trig Source**

Spectrum (Frequency-Domain) Measurement

Commands for querying the spectrum measurement results and for setting to the default values are found in the “MEASure Group of Commands” on page 213. The equivalent front panel keys for the parameters described in the following commands, are found under the **Meas Setup** key, after the **Spectrum (Freq Domain)** measurement has been selected from the **MEASURE** key menu.

Spectrum—Data Acquisition Packing

```
[ :SENSe ] :SPECTrum:ACQuisition:PACKing  
AUTO | LONG | MEDium | SHORt
```

```
[ :SENSe ] :SPECTrum:ACQuisition:PACKing?
```

Select the amount of data acquisition packing. This is an advanced control that normally does not need to be changed.

Factory Preset: AUTO

Remarks: To use this command for E4406A, the appropriate mode should be selected with INSTRument:SElect.

For PSA you must be in the Basic, cdmaOne, cdma2000, 1xEV-DO, W-CDMA, GSM, EDGE, NADC, or PDC mode to use this command. Use INSTRument:SElect to set the mode.

Spectrum—ADC Dither

```
[ :SENSe ] :SPECTrum:ADC:DITHer [ :STATe ] AUTO | ON | OFF | 2 | 1 | 0
```

```
[ :SENSe ] :SPECTrum:ADC:DITHer [ :STATe ] ?
```

Turn the ADC dither on or off. This is an advanced control that normally does not need to be changed.

Factory Preset: AUTO

Remarks: To use this command for E4406A, the appropriate mode should be selected with INSTRument:SElect.

For PSA you must be in the Basic, cdmaOne, cdma2000, 1xEV-DO, W-CDMA, GSM, EDGE, NADC, or PDC mode to use this command. Use INSTRument:SElect to set the mode.

Spectrum—ADC Range

E4406A

```
[ :SENSe ] :SPECTrum:ADC:RANGe
```

AUTO | APEak | APLock | M6 | P0 | P6 | P12 | P18 | P24

PSA

[:SENSe] :SPECTrum:ADC:RANGe

AUTO | APEak | APLock | NONE | P0 | P6 | P12 | P18

[:SENSe] :SPECTrum:ADC:RANGe?

Select the range for the gain-ranging that is done in front of the ADC. This is an advanced control that normally does not need to be changed. Auto peak ranging is the default for this measurement. If you are measuring a CW signal please see the description below.

- AUTO - automatic range

For FFT spectrums - auto ranging should not be used. An exception to this would be if you know that your signal is “bursty”. Then you might use auto to maximize the time domain dynamic range as long as you are not very interested in the FFT data.

- Auto Peak (APEak) - automatically peak the range

For CW signals, the default of auto-peak ranging can be used, but a better FFT measurement of the signal can be made by selecting one of the manual ranges that are available: M6, P0 - P24.

Auto peaking can cause the ADC range gain to move monotonically down during the data capture. This movement should have negligible effect on the FFT spectrum, but selecting a manual range removes this possibility. Note that if the CW signal being measured is close to the auto-ranging threshold, the noise floor may shift as much as 6 dB from sweep to sweep.

- Auto Peak Lock (APLock) - automatically peak lock the range

For CW signals, auto-peak lock ranging may be used. It will find the best ADC measurement range for this particular signal and will not move the range as auto-peak can. Note that if the CW signal being measured is close to the auto-ranging threshold, the noise floor may shift as much as 6 dB from sweep to sweep.

For “bursty” signals, auto-peak lock ranging should not be used. The measurement will fail to operate, since the wrong (locked) ADC range will be chosen often and overloads will occur in the ADC.

- NONE - (PSA) turns off any auto-ranging without making any changes to the current setting.
- M6 - (E4406A) manually selects an ADC range that subtracts 6 dB of fixed gain across the range. Manual ranging is best for CW signals.
- P0 to P18 - (PSA) manually selects ADC ranges that add 0 to 18 dB of fixed gain across the range. Manual ranging is best for CW signals.

- P0 to 24 - (E4406A) manually selects ADC ranges that add 0 to 24 dB of fixed gain across the range. Manual ranging is best for CW signals.

Factory Preset: APEak

Remarks: To use this command for E4406A, the appropriate mode should be selected with INSTRUMENT:SElect.

For PSA you must be in the Basic, cdmaOne, cdma2000, 1xEV-DO, W-CDMA, GSM, EDGE, NADC, or PDC mode to use this command. Use INSTRUMENT:SElect to set the mode.

Spectrum—Average Clear

`[:SENSe] :SPECTrum:AVERAge:CLEar`

The average data is cleared and the average counter is reset.

Remarks: To use this command for E4406A, the appropriate mode should be selected with INSTRUMENT:SElect.

For PSA you must be in the Basic, cdmaOne, cdma2000, 1xEV-DO, W-CDMA, GSM, EDGE, NADC, or PDC mode to use this command. Use INSTRUMENT:SElect to set the mode.

Spectrum—Number of Averages

`[:SENSe] :SPECTrum:AVERAge:COUNT <integer>`

`[:SENSe] :SPECTrum:AVERAge:COUNT?`

Set the number of 'sweeps' that will be averaged. After the specified number of 'sweeps' (average counts), the averaging mode (terminal control) setting determines the averaging action.

Factory Preset: 25

Range: 1 to 10,000

Remarks: To use this command for E4406A, the appropriate mode should be selected with INSTRUMENT:SElect.

For PSA you must be in the Basic, cdmaOne, cdma2000, 1xEV-DO, W-CDMA, GSM, EDGE, NADC, or PDC mode to use this command. Use INSTRUMENT:SElect to set the mode.

Spectrum—Averaging State

```
[ :SENSe] :SPECTrum:AVERAge [:STATe] OFF | ON | 0 | 1
```

```
[ :SENSe] :SPECTrum:AVERAge [:STATe] ?
```

Turn averaging on or off.

Factory Preset: ON

Remarks: To use this command for E4406A, the appropriate mode should be selected with INSTRUMENT:SELECT.

For PSA you must be in the Basic, cdmaOne, cdma2000, 1xEV-DO, W-CDMA, GSM, EDGE, NADC, or PDC mode to use this command. Use INSTRUMENT:SELECT to set the mode.

Spectrum—Averaging Mode

```
[ :SENSe] :SPECTrum:AVERAge:TCONTRol EXPonential | REPeat
```

```
[ :SENSe] :SPECTrum:AVERAge:TCONTRol ?
```

Select the type of termination control used for the averaging function. This determines the averaging action after the specified number of 'sweeps' (average count) is reached.

EXPonential - Each successive data acquisition after the average count is reached, is exponentially weighted and combined with the existing average.

REPeat - After reaching the average count, the averaging is reset and a new average is started.

Factory Preset: EXPonential

Remarks: To use this command for E4406A, the appropriate mode should be selected with INSTRUMENT:SELECT.

For PSA you must be in the Basic, cdmaOne, cdma2000, 1xEV-DO, W-CDMA, GSM, EDGE, NADC, or PDC mode to use this command. Use INSTRUMENT:SELECT to set the mode.

Spectrum—Averaging Type

```
[ :SENSe] :SPECTrum:AVERAge:TYPE  
LOG | MAXimum | MINimum | RMS | SCALar
```

```
[ :SENSe] :SPECTrum:AVERAge:TYPE?
```

Select the type of averaging.

LOG – The log of the power is averaged. (This is also known as video averaging.)

MAXimum – The maximum values are retained.

MINimum – The minimum values are retained.

RMS – The power is averaged, providing the rms of the voltage.

SCALar – The voltage is averaged.

Factory Preset: LOG

Remarks: To use this command for E4406A, the appropriate mode should be selected with INSTRUMENT:SElect.

For PSA you must be in the Basic, cdmaOne, cdma2000, 1xEV-DO, W-CDMA, GSM, EDGE, NADC, or PDC mode to use this command. Use INSTRUMENT:SElect to set the mode.

Spectrum— Select Pre-FFT Bandwidth

```
[ :SENSe ] :SPECTrum: BANDwidth | BWIDth: IF: AUTO OFF | ON | 0 | 1
```

```
[ :SENSe ] :SPECTrum: BANDwidth | BWIDth: IF: AUTO?
```

Select auto or manual control of the pre-FFT BW.

Factory Preset: AUTO, 1.55 MHz

Remarks: To use this command for E4406A, the appropriate mode should be selected with INSTRUMENT:SElect.

For PSA you must be in the Basic, cdmaOne, cdma2000, 1xEV-DO, W-CDMA, GSM, EDGE, NADC, or PDC mode to use this command. Use INSTRUMENT:SElect to set the mode.

Front Panel

Access: **Measure, Spectrum, Meas Setup, More, Advanced, Pre-FFT BW.**

Spectrum — IF Flatness Corrections

```
[ :SENSe ] :SPECTrum: BANDwidth | BWIDth: IF: FLATness OFF | ON | 0 | 1
```

```
[ :SENSe ] :SPECTrum: BANDwidth | BWIDth: IF: FLATness?
```

Turns IF flatness corrections on and off.

Factory Preset: ON

Remarks: To use this command for E4406A, the appropriate mode should be selected with INSTRUMENT:SElect.

For PSA you must be in the Basic, cdmaOne, cdma2000, 1xEV-DO, W-CDMA, GSM, EDGE, NADC, or PDC mode to use this command. Use INSTRument:SElect to set the mode.

Front Panel

Access: **Measure, Spectrum, Meas Setup, More, Advanced, Pre-FFT BW**

Spectrum—Pre-ADC Bandpass Filter

```
[ :SENSE ] :SPECTrum: BANDwidth | BWIDth: PADC OFF | ON | 0 | 1
```

```
[ :SENSE ] :SPECTrum: BANDwidth | BWIDth: PADC ?
```

Turn the pre-ADC bandpass filter on or off. This is an advanced control that normally does not need to be changed.

Remarks: To use this command for E4406A, the appropriate mode should be selected with INSTRument:SElect.

For PSA you must be in the Basic, cdmaOne, cdma2000, 1xEV-DO, W-CDMA, GSM, EDGE, NADC, or PDC mode to use this command. Use INSTRument:SElect to set the mode.

Spectrum—Pre-FFT BW

```
[ :SENSE ] :SPECTrum: BANDwidth | BWIDth: PFFT [ :SIZE ] <freq>
```

```
[ :SENSE ] :SPECTrum: BANDwidth | BWIDth: PFFT [ :SIZE ] ?
```

Set the pre-FFT bandwidth. This is an advanced control that normally does not need to be changed.

Frequency span, resolution bandwidth, and the pre-FFT bandwidth settings are normally coupled. If you are not auto-coupled, there can be combinations of these settings that are not valid.

Factory Preset: 1.55 MHz

1.25 MHz for cdmaOne

155.0 kHz, for iDEN mode (E4406A)

Range: 1 Hz to 10.0 MHz

Remarks: To use this command for E4406A, the appropriate mode should be selected with INSTRument:SElect.

For PSA you must be in the Basic, cdmaOne, cdma2000, 1xEV-DO, W-CDMA, GSM, EDGE, NADC, or PDC mode to use this command. Use

INSTRument:SElect to set the mode.

Spectrum—Pre-FFT BW Filter Type

```
[ :SENSe ] :SPECTrum: BANDwidth | BWIDth: PFFT: TYPE FLAT | GAUSSian
```

```
[ :SENSe ] :SPECTrum: BANDwidth | BWIDth: PFFT: TYPE?
```

Select the type of pre-FFT filter that is used. This is an advanced control that normally does not need to be changed.

Flat top (FLAT)- a filter with a flat amplitude response, which provides the best amplitude accuracy.

GAUSSian - a filter with Gaussian characteristics, which provides the best pulse response.

Factory Preset: FLAT

Remarks: To use this command for E4406A, the appropriate mode should be selected with INSTRument:SElect.

For PSA you must be in the Basic, cdmaOne, cdma2000, 1xEV-DO, W-CDMA, GSM, EDGE, NADC, or PDC mode to use this command. Use INSTRument:SElect to set the mode.

Spectrum—Resolution BW

```
[ :SENSe ] :SPECTrum: BANDwidth | BWIDth [ :RESolution ] <freq>
```

```
[ :SENSe ] :SPECTrum: BANDwidth | BWIDth [ :RESolution ] ?
```

Set the resolution bandwidth for the FFT. This is the bandwidth used for resolving the FFT measurement. It is not the pre-FFT bandwidth. This value is ignored if the function is auto-coupled.

Frequency span, resolution bandwidth, and the pre-FFT bandwidth settings are normally coupled. If you are not auto-coupled, there can be combinations of these settings that are not valid.

Factory Preset: 20.0 kHz

250.0 Hz, for iDEN mode (E4406A)

Range: 0.10 Hz to 3.0 MHz

Remarks: To use this command for E4406A, the appropriate mode should be selected with INSTRument:SElect.

For PSA you must be in the Basic, cdmaOne, cdma2000, 1xEV-DO, W-CDMA, GSM, EDGE, NADC, or PDC mode to use this command. Use INSTRument:SElect to set the mode.

Spectrum—Resolution BW Auto

```
[ :SENSE ] :SPECTrum: BANDwidth | BWIDth [ :RESolution ] :AUTO  
OFF | ON | 0 | 1
```

```
[ :SENSE ] :SPECTrum: BANDwidth | BWIDth [ :RESolution ] :AUTO?
```

Select auto or manual control of the resolution BW. The automatic mode couples the resolution bandwidth setting to the frequency span.

Factory Preset: ON

OFF, for iDEN mode (E4406A)

Remarks: To use this command for E4406A, the appropriate mode should be selected with INSTRUMENT:SELECT.

For PSA you must be in the Basic, cdmaOne, cdma2000, W-CDMA, GSM, EDGE, NADC, or PDC mode to use this command. Use INSTRUMENT:SELECT to set the mode.

Decimation of Spectrum Display

```
[ :SENSE ] :SPECTrum: DECimate [ :FACTor ] <integer>
```

```
[ :SENSE ] :SPECTrum: DECimate [ :FACTor ] ?
```

Sets the amount of data decimation done by the hardware and/or the software. Decimation by n keeps every nth sample, throwing away each of the remaining samples in the group of n. For example, decimation by 3 keeps every third sample, throwing away the two in between. Similarly, decimation by 5 keeps every fifth sample, throwing away the four in between.

Using zero (0) decimation selects the automatic mode. The measurement will then automatically choose decimation by “1” or “2” as is appropriate for the bandwidth being used.

This is an advanced control that normally does not need to be changed.

Factory Preset: 0

Range: 0 to 1,000, where 0 sets the function to automatic

Remarks: To use this command for E4406A, the appropriate mode should be selected with INSTRUMENT:SELECT.

For PSA you must be in the Basic, cdmaOne, cdma2000, 1xEV-DO, W-CDMA, GSM, EDGE, NADC, or PDC mode to use this command. Use INSTRUMENT:SELECT to set the mode.

History: E4406A:
Version A.02.00 or later

Spectrum—FFT Length

`[:SENSe] :SPECTrum:FFT:LENGth <integer>`

`[:SENSe] :SPECTrum:FFT:LENGth?`

Set the FFT length. This value is only used if length control is set to manual. The value must be greater than or equal to the window length value. Any amount greater than the window length is implemented by zero-padding. This is an advanced control that normally does not need to be changed.

Factory Preset: 706

Range: min, depends on the current setting of the spectrum window length
max, 1,048,576

Remarks: To use this command for E4406A, the appropriate mode should be selected with `INSTRument:SElect`.

For PSA you must be in the Basic, `cdmaOne`, `cdma2000`, `1xEV-DO`, `W-CDMA`, `GSM`, `EDGE`, `NADC`, or `PDC` mode to use this command. Use `INSTRument:SElect` to set the mode.

History: E4406A:
Short form changed from `LENGth` to `LENGth`, A.03.00

Spectrum—FFT Length Auto

`[:SENSe] :SPECTrum:FFT:LENGth:AUTO OFF | ON | 0 | 1`

`[:SENSe] :SPECTrum:FFT:LENGth:AUTO?`

Select auto or manual control of the FFT and window lengths.

This is an advanced control that normally does not need to be changed.

On - the window lengths are coupled to resolution bandwidth, window type (FFT), pre-FFT bandwidth (sample rate) and `SENSe:SPECTrum:FFT:RBWPoints`.

Off - lets you set `SENSe:SPECTrum:FFT:LENGth` and `SENSe:SPECTrum:FFT:WINDow:LENGth`.

Factory Preset: ON

Remarks: To use this command for E4406A, the appropriate mode should be selected with `INSTRument:SElect`.

For PSA you must be in the Basic, cdmaOne, cdma2000, 1xEV-DO, W-CDMA, GSM, EDGE, NADC, or PDC mode to use this command. Use INSTRument:SElect to set the mode.

History: E4406A:
Short form changed from LENgth to LENGth, A.03.00

Spectrum—FFT Minimum Points in Resolution BW

`[:SENSe] :SPECTrum:FFT:RBWPoints <real>`

`[:SENSe] :SPECTrum:FFT:RBWPoints?`

Set the minimum number of data points that will be used inside the resolution bandwidth. The value is ignored if length control is set to manual. This is an advanced control that normally does not need to be changed.

Factory Preset: 1.30

Range: 0.1 to 100

Remarks: To use this command for E4406A, the appropriate mode should be selected with INSTRument:SElect.

For PSA you must be in the Basic, cdmaOne, cdma2000, 1xEV-DO, W-CDMA, GSM, EDGE, NADC, or PDC mode to use this command. Use INSTRument:SElect to set the mode.

Spectrum—Window Delay

`[:SENSe] :SPECTrum:FFT:WINDow:DELay <real>`

`[:SENSe] :SPECTrum:FFT:WINDow:DELay?`

Set the FFT window delay to move the FFT window from its nominal position of being centered within the time capture. This function is not available from the front panel. It is an advanced control that normally does not need to be changed.

Factory Preset: 0

Range: -10.0 to +10.0s

Default Unit: seconds

Remarks: To use this command for E4406A, the appropriate mode should be selected with INSTRument:SElect.

For PSA you must be in the Basic, cdmaOne, cdma2000, 1xEV-DO, W-CDMA, GSM, EDGE, NADC,

or PDC mode to use this command. Use
INSTRument:SElect to set the mode.

Spectrum—Window Length

`[:SENSe] :SPEctrum:FFT:WINDow:LENGth <integer>`

`[:SENSe] :SPEctrum:FFT:WINDow:LENGth?`

Set the FFT window length. This value is only used if length control is set to manual. This is an advanced control that normally does not need to be changed.

Factory Preset: 706

Range: 8 to 1,048,576

Remarks: To use this command for E4406A, the appropriate mode should be selected with INSTRument:SElect.

For PSA you must be in the Basic, cdmaOne, cdma2000, 1xEV-DO, W-CDMA, GSM, EDGE, NADC, or PDC mode to use this command. Use INSTRument:SElect to set the mode.

History: E4406A:
Short form changed from LENgth to LENGth, A.03.00

Spectrum—FFT Window

`[:SENSe] :SPEctrum:FFT:WINDow [:TYPE] BH4Tap | BLACkman | FLATtop | GAUSSian | HAMMing | HANNing | KB70 | KB90 | KB110 | UNIFORM`

`[:SENSe] :SPEctrum:FFT:WINDow [:TYPE] ?`

Select the FFT window type.

BH4Tap - Blackman Harris with 4 taps

BLACkman - Blackman

FLATtop - flat top, the default (for high amplitude accuracy)

GAUSSian - Gaussian with alpha of 3.5

HAMMing - Hamming

HANNing - Hanning

KB70, 90, and 110 - Kaiser Bessel with sidelobes at -70, -90, or -110 dBc

UNIFORM - no window is used. (This is the unity response.)

Factory Preset: FLATtop

Remarks: This selection affects the acquisition point quantity and the FFT size, based on the resolution bandwidth selected.

To use this command for E4406A, the appropriate mode should be selected with INSTRUMENT:SELECT.

For PSA you must be in the Basic, cdmaOne, cdma2000, 1xEV-DO, W-CDMA, GSM, EDGE, NADC, or PDC mode to use this command. Use INSTRUMENT:SELEct to set the mode.

Spectrum—Frequency Span

[:SENSE] :SPECTrum:FREQuency:SPAN <freq>

[:SENSE] :SPECTrum:FREQuency:SPAN?

Set the frequency span to be measured.

Factory Preset: 1.0 MHz

100.0 kHz for iDEN mode (E4406A)

Range: 10 Hz to 10.0 MHz (15 MHz when Service mode is selected)

Default Unit: Hz

Remarks: The actual measured span will generally be slightly wider due to the finite resolution of the FFT.

To use this command for E4406A, the appropriate mode should be selected with INSTRUMENT:SELECT.

For PSA you must be in the Basic, cdmaOne, cdma2000, 1xEV-DO, W-CDMA, GSM, EDGE, NADC, or PDC mode to use this command. Use INSTRUMENT:SELEct to set the mode.

Spectrum—Sweep (Acquisition) Time

[:SENSE] :SPECTrum:SWEep:TIME [:VALue] <time>

[:SENSE] :SPECTrum:SWEep:TIME?

Set the sweep (measurement acquisition) time. It is used to specify the length of the time capture record. If the value you specify is less than the capture time required for the specified span and resolution bandwidth, the value is ignored. The value is set at its auto value when auto is selected. This is an advanced control that normally does not need to be changed.

Factory Preset: 188.0 μ s
15.059 ms, for iDEN mode (E4406A)

Range: 100 ns to 10 s

Default Unit: seconds

Remarks: To use this command for E4406A, the appropriate mode should be selected with INSTRUMENT:SElect.

For PSA you must be in the Basic, cdmaOne, cdma2000, 1xEV-DO, W-CDMA, GSM, EDGE, NADC, or PDC mode to use this command. Use INSTRUMENT:SElect to set the mode.

Spectrum—Sweep (Acquisition) Time Auto

```
[ :SENSe ] :SPECTrum:SWEep:TIME:AUTO OFF | ON | 0 | 1
```

```
[ :SENSe ] :SPECTrum:SWEep:TIME:AUTO
```

Select auto or manual control of the sweep (acquisition) time. This is an advanced control that normally does not need to be changed.

AUTO - couples the Sweep Time to the Frequency Span and Resolution BW

Manual - the Sweep Time is uncoupled from the Frequency Span and Resolution BW.

Factory Preset: AUTO

Remarks: To use this command for E4406A, the appropriate mode should be selected with INSTRUMENT:SElect.

For PSA you must be in the Basic, cdmaOne, cdma2000, 1xEV-DO, W-CDMA, GSM, EDGE, NADC, or PDC mode to use this command. Use INSTRUMENT:SElect to set the mode.

Spectrum—Trigger Source

```
[ :SENSe ] :SPECTrum:TRIGger:SOURce EXTernal [1] | EXTernal2  
| FRAME | IF | LINE | IMMEDIATE | RFBURST
```

```
[ :SENSe ] :SPECTrum:TRIGger:SOURce?
```

Select the trigger source used to control the data acquisitions.

EXTernal1 - front panel external trigger input

EXTernal2 - rear panel external trigger input

FRAMe - internal frame timer from front panel input

IF - internal IF envelope (video) trigger

LINE - internal line trigger

IMMEDIATE - the next data acquisition is immediately taken (also called free run)

RFBurst - wideband RF burst envelope trigger that has automatic level control for periodic burst signals

Factory Preset: IMMEDIATE (free run)

RFBurst, for GSM, iDEN mode

Remarks: To use this command for E4406A, the appropriate mode should be selected with INSTRUMENT:SELECT.

For PSA you must be in the Basic, cdmaOne, cdma2000, 1xEV-DO, W-CDMA, GSM, EDGE, NADC, or PDC mode to use this command. Use INSTRUMENT:SELECT to set the mode.

Synchronization Commands

Sync Type

[:SENSE] :SYNC ESECond | EXTERNAL [1] | EXTERNAL2 | NONE | PSEQUENCE

[:SENSE] :SYNC?

Select the demodulation sync type for the waveform accuracy (Rho) and code domain power measurements.

Even Second (ESECond) - Even second clock

EXTERNAL 1 - front panel external trigger input

EXTERNAL 2 - rear panel external trigger input

NONE - no demod sync (uses free run trigger)

Pilot Sequence (PSEQUENCE) - pilot sequence sync (uses frame trigger)

Factory Preset: ESECond

Remarks: Global to the current mode.

You must be in the cdmaOne mode to use this command. Use INSTRUMENT:SELECT to set the mode.

Front Panel

Access: **Mode Setup, Trigger, Sync Type**

History: E4406A:
Front/Rear panel swapped EXT2/EXT1, A.03.00

Waveform (Time-Domain) Measurement

Commands for querying the waveform measurement results and for setting to the default values are found in the “[MEASure Group of Commands](#)” on page 213. The equivalent front panel keys for the parameters described in the following commands, are found under the **Meas Setup** key, after the **Waveform (Time Domain)** measurement has been selected from the **MEASURE** key menu.

Waveform—Data Acquisition Packing

```
[ :SENSe ] :WAVeform:ACQuIstion:PACKing AUTO | LONG | MEDium | SHORt
```

```
[ :SENSe ] :WAVeform:ACQuIstion:PACKing?
```

This is an advanced control that normally does not need to be changed.

Factory Preset: AUTO

Remarks: To use this command for E4406A, the appropriate mode should be selected with INSTRument:SElect.

For PSA you must be in the Basic, cdmaOne, cdma2000, 1xEV-DO, W-CDMA, GSM, EDGE, NADC, or PDC mode to use this command. Use INSTRument:SElect to set the mode.

Waveform—ADC Dither State

```
[ :SENSe ] :WAVeform:ADC:DITHer [ :STATe ] OFF | ON | 0 | 1
```

```
[ :SENSe ] :WAVeform:ADC:DITHer [ :STATe ] ?
```

This is an Advanced control that normally does not need to be changed.

Factory Preset: OFF

Remarks: To use this command for E4406A, the appropriate mode should be selected with INSTRument:SElect.

For PSA you must be in the Basic, cdmaOne, cdma2000, 1xEV-DO, W-CDMA, GSM, EDGE, NADC, or PDC mode to use this command. Use INSTRument:SElect to set the mode.

Waveform—Pre-ADC Bandpass Filter

```
[ :SENSe ] :WAVeform:ADC:FILTer [ :STATe ] OFF | ON | 0 | 1
```

```
[ :SENSe ] :WAVeform:ADC:FILTer [ :STATe ] ?
```

Turn the pre-ADC bandpass filter on or off. This is an Advanced control that normally does not need to be changed.

Preset: OFF

Remarks: To use this command for E4406A, the appropriate mode should be selected with INSTRUMENT:SELECT.

For PSA you must be in the Basic, cdmaOne, cdma2000, 1xEV-DO, W-CDMA, GSM, EDGE, NADC, or PDC mode to use this command. Use INSTRUMENT:SELEct to set the mode.

Waveform—ADC Range

E4406A

```
[ :SENSe ] :WAVeform:ADC:RANGe AUTO | APEak | APLock | GROund
| M6 | P0 | P6 | P12 | P18 | P24
```

PSA

```
[ :SENSe ] :WAVeform:ADC:RANGe AUTO | APEak | APLock | GROund
| NONE | P0 | P6 | P12 | P18
```

```
[ :SENSe ] :WAVeform:ADC:RANGe?
```

Select the range for the gain-ranging that is done in front of the ADC. This is an Advanced control that normally does not need to be changed.

AUTO - automatic range

Auto Peak (APEak) - automatically peak the range

Auto Peak Lock (APLock)- automatically peak lock the range

GROund - ground

NONE - (PSA) turn off auto-ranging without making any changes to the current setting.

M6 - (E4406A) subtracts 6 dB of fixed gain across the range

P0 to P18 - (PSA) adds 0 to 18 dB of fixed gain across the range

P0 to P24 - (E4406A) adds 0 to 24 dB of fixed gain across the range

Factory Preset: AUTO

Remarks: To use this command for E4406A, the appropriate mode should be selected with INSTRUMENT:SELECT.

For PSA you must be in the Basic, cdmaOne, cdma2000, 1xEV-DO, W-CDMA, GSM, EDGE, NADC, or PDC mode to use this command. Use INSTRUMENT:SELEct to set the mode.

Waveform - Query Aperture Setting

`[:SENSe] :WAVeform:APERture?`

Returns the waveform sample period (aperture) based on current resolution bandwidth, filter type, and decimation factor. Sample rate is the reciprocal of period.

Remarks: To use this command for E4406A, the appropriate mode should be selected with `INSTRument:SElect`.

For PSA you must be in the Basic, `cdmaOne`, `cdma2000`, `1xEV-DO`, `W-CDMA`, `GSM`, `EDGE`, `NADC`, or `PDC` mode to use this command. Use `INSTRument:SElect` to set the mode.

Waveform—Number of Averages

`[:SENSe] :WAVeform:AVERage:COUNT <integer>`

`[:SENSe] :WAVeform:AVERage:COUNT?`

Set the number of sweeps that will be averaged. After the specified number of sweeps (average counts), the averaging mode (terminal control) setting determines the averaging action.

Factory Preset: 10

Range: 1 to 10,000

Remarks: To use this command for E4406A, the appropriate mode should be selected with `INSTRument:SElect`.

For PSA you must be in the Basic, `cdmaOne`, `cdma2000`, `1xEV-DO`, `W-CDMA`, `GSM`, `EDGE`, `NADC`, or `PDC` mode to use this command. Use `INSTRument:SElect` to set the mode.

Waveform—Averaging State

`[:SENSe] :WAVeform:AVERage [:STATe] OFF | ON | 0 | 1`

`[:SENSe] :WAVeform:AVERage [:STATe] ?`

Turn averaging on or off.

Factory Preset: OFF

Remarks: To use this command for E4406A, the appropriate mode should be selected with INSTRUMENT:SELECT.

For PSA you must be in the Basic, cdmaOne, cdma2000, 1xEV-DO, W-CDMA, GSM, EDGE, NADC, or PDC mode to use this command. Use INSTRUMENT:SELECT to set the mode.

Waveform—Averaging Mode

```
[ :SENSe ] :WAVeform:AVERAge:TCONtrol EXPonential | REPeat
```

```
[ :SENSe ] :WAVeform:AVERAge:TCONtrol?
```

Select the type of termination control used for the averaging function. This determines the averaging action after the specified number of 'sweeps' (average count) is reached.

EXPonential - Each successive data acquisition after the average count is reached, is exponentially weighted and combined with the existing average.

REPeat - After reaching the average count, the averaging is reset and a new average is started.

Factory Preset: EXPonential

Remarks: To use this command for E4406A, the appropriate mode should be selected with INSTRUMENT:SELECT.

For PSA you must be in the Basic, cdmaOne, cdma2000, 1xEV-DO, W-CDMA, GSM, EDGE, NADC, or PDC mode to use this command. Use INSTRUMENT:SELECT to set the mode.

Waveform—Averaging Type

```
[ :SENSe ] :WAVeform:AVERAge:TYPE
```

```
LOG | MAXimum | MINimum | RMS | SCALar
```

```
[ :SENSe ] :WAVeform:AVERAge:TYPE?
```

Select the type of averaging.

LOG - The log of the power is averaged. (This is also known as video averaging.)

MAXimum - The maximum values are retained.

MINimum - The minimum values are retained.

RMS - The power is averaged, providing the rms of the voltage.

Factory Preset: RMS

Remarks: To use this command for E4406A, the appropriate mode should be selected with INSTRUMENT:SElect.

For PSA you must be in the Basic, cdmaOne, cdma2000, 1xEV-DO, W-CDMA, GSM, EDGE, NADC, or PDC mode to use this command. Use INSTRUMENT:SElect to set the mode.

Waveform—Resolution BW

```
[ :SENSe ] :WAVeform: BANDwidth | BWIDth [ :RESolution ] <freq>
```

```
[ :SENSe ] :WAVeform: BANDwidth | BWIDth [ :RESolution ] ?
```

Set the resolution bandwidth. This value is ignored if the function is auto-coupled.

Factory Preset: 100.0 kHz for NADC, PDC, cdma2000, W-CDMA, Basic, Service (E4406A)
500.0 kHz for GSM
2.0 MHz for cdmaOne

Range: 1.0 kHz to 8.0 MHz when
[:SENSe]:WAVeform: BANDwidth | BWIDth
[:RESolution]:TYPE GAUSSian

1.0 kHz to 10.0 MHz when
[:SENSe]:WAVeform: BANDwidth | BWIDth
[:RESolution]:TYPE FLATtop

Remarks: To use this command for E4406A, the appropriate mode should be selected with INSTRUMENT:SElect.

For PSA you must be in the Basic, cdmaOne, cdma2000, 1xEV-DO, W-CDMA, GSM, EDGE, NADC, or PDC mode to use this command. Use INSTRUMENT:SElect to set the mode.

Bandwidths > 6.7 MHz will require a slight increase in measurement time.

Waveform - Query Actual Resolution Bandwidth

```
[ :SENSe ] :WAVeform: BANDwidth: RESolution ] :ACTual ?
```

Due to memory constraints the actual resolution bandwidth value may vary from the value entered by the user. For most applications the resulting difference in value is inconsequential but for some it is necessary to know the actual value; this query retrieves the actual resolution bandwidth value.

Remarks: To use this command for E4406A, the appropriate mode

should be selected with INSTRUMENT:SElect.

For PSA you must be in the Basic, cdmaOne, cdma2000, 1xEV-DO, W-CDMA, GSM, EDGE, NADC, or PDC mode to use this command. Use INSTRUMENT:SElect to set the mode.

History: E4406A:
Version A.05.00 or later

Waveform—Resolution BW Filter Type

```
[ :SENSE ] :WAVEform:BANDwidth | BWIDth [ :RESolution ] :TYPE  
FLATtop | GAUSSian
```

```
[ :SENSE ] :WAVEform:BANDwidth | BWIDth [ :RESolution ] :TYPE?
```

Select the type of Resolution BW filter that is used. This is an Advanced control that normally does not need to be changed.

FLATtop - a filter with a flat amplitude response, which provides the best amplitude accuracy.

GAUSSian - a filter with Gaussian characteristics, which provides the best pulse response.

Factory Preset: GAUSSian

Remarks: To use this command for E4406A, the appropriate mode should be selected with INSTRUMENT:SElect.

For PSA you must be in the Basic, cdmaOne, cdma2000, 1xEV-DO, W-CDMA, GSM, EDGE, NADC, or PDC mode to use this command. Use INSTRUMENT:SElect to set the mode.

Waveform—Decimation of Waveform Display

```
[ :SENSE ] :WAVEform:DECimate [ :FACTor ] <integer>
```

```
[ :SENSE ] :WAVEform:DECimate [ :FACTor ] ?
```

Set the amount of data decimation done on the IQ data stream. For example, if 4 is selected, three out of every four data points will be thrown away. So every 4th data point will be kept.

Factory Preset: 1

Range: 1 to 4

Remarks: To use this command for E4406A, the appropriate mode should be selected with INSTRUMENT:SElect.

For PSA you must be in the Basic, cdmaOne,

cdma2000, 1xEV-DO, W-CDMA, GSM, EDGE, NADC, or PDC mode to use this command. Use INSTRument:SElect to set the mode.

Waveform—Control Decimation of Waveform Display

[:SENSe] :WAVeform:DECimate:STATe OFF|ON|0|1

[:SENSe] :WAVeform:DECimate:STATe?

Set the amount of data decimation done by the hardware in order to decrease the number of acquired points in a long capture time. This is the amount of data that the measurement ignores.

Factory Preset: OFF

Remarks: To use this command for E4406A, the appropriate mode should be selected with INSTRument:SElect.

For PSA you must be in the Basic, cdmaOne, cdma2000, 1xEV-DO, W-CDMA, GSM, EDGE, NADC, or PDC mode to use this command. Use INSTRument:SElect to set the mode.

Waveform—Sweep (Acquisition) Time

[:SENSe] :WAVeform:SWEep:TIME <time>

[:SENSe] :WAVeform:SWEep:TIME?

Set the measurement acquisition time. It is used to specify the length of the time capture record.

Factory Preset: 2.0 ms

10.0 ms, for NADC, PDC

15.0 ms, for iDEN mode (E4406A)

Range: 1 μ s to 100 s

Default Unit: seconds

Remarks: To use this command for E4406A, the appropriate mode should be selected with INSTRument:SElect.

For PSA you must be in the Basic, cdmaOne, cdma2000, 1xEV-DO, W-CDMA, GSM, EDGE, NADC, or PDC mode to use this command. Use INSTRument:SElect to set the mode.

Waveform—Trigger Source

```
[ :SENSE ] :WAVEform:TRIGger:SOURce EXTernal [1] |  
EXTernal2 | FRAME | IF | IMMEDIATE | LINE | RFBURSt
```

```
[ :SENSE ] :WAVEform:TRIGger:SOURce?
```

Select the trigger source used to control the data acquisitions.

EXTernal 1 - front panel external trigger input

EXTernal 2 - rear panel external trigger input

FRAME - internal frame timer from front panel input

IF - internal IF envelope (video) trigger

IMMEDIATE - the next data acquisition is immediately taken (also called free run)

LINE - internal line trigger

RFBURSt - wideband RF burst envelope trigger that has automatic level control for periodic burst signals

Factory Preset: IMMEDIATE (free run), for Basic, cdmaOne, NADC, PDC mode

RFBURSt, for GSM, iDEN (E4406A) modes

Remarks: To use this command for E4406A, the appropriate mode should be selected with INSTRUMENT:SELECT.

For PSA you must be in the Basic, cdmaOne, cdma2000, 1xEV-DO, W-CDMA, GSM, EDGE, NADC, or PDC mode to use this command. Use INSTRUMENT:SELECT to set the mode.

TRIGger Subsystem

The Trigger Subsystem is used to set the controls and parameters associated with triggering the data acquisitions. Other trigger-related commands are found in the INITiate and ABORt subsystems.

The trigger parameters are global within a selected Mode. The commands in the TRIGger subsystem set up the way the triggers function, but selection of the trigger source is made from each measurement. There is a separate trigger source command in the SENSE:<meas> subsystem for each measurement. The equivalent front panel keys for the parameters described in the following commands, can be found under the **Mode Setup, Trigger** key.

Automatic Trigger Control

```
:TRIGger[:SEquence]:AUTO:STATE OFF|ON|0|1
```

```
:TRIGger[:SEquence]:AUTO:STATE?
```

Turns the automatic trigger function on and off. This function causes a trigger to occur if the designated time has elapsed and no trigger occurred. It can be used with unpredictable trigger sources, like external or burst, to make sure a measurement is initiated even if a trigger doesn't occur. Use TRIGger[:SEquence]:AUTO[:TIME] to set the time limit.

Factory Preset
and *RST Off for cdma2000, W-CDMA, NADC, PDC, 1xEV-DO

Front Panel
Access **Mode Setup, Trigger, Auto Trig**

Automatic Trigger Time

```
:TRIGger[:SEquence]:AUTO[:TIME] <time>
```

```
:TRIGger[:SEquence]:AUTO[:TIME]?
```

After the measurement is activated the instrument will take a data acquisition immediately upon receiving a signal from the selected trigger source. If no trigger signal is received by the end of the time specified in this command, a data acquisition is taken anyway. TRIGger[:SEquence]:AUTO:STATE must be on.

Factory Preset: 100.0 ms

Range: 1.0 ms to 1000.0 s
0.0 to 1000.0 s for cdma2000, W-CDMA, 1xEV-DO

Default Unit: seconds
Front Panel
Access **Mode Setup, Trigger, Auto Trig**

External Trigger Delay

```
:TRIGger[:SEquence]:EXTernal[1]|2:DElay <time>
:TRIGger[:SEquence]:EXTernal[1]|2:DElay?
```

Set the trigger delay when using an external trigger. Set the trigger value to zero (0) seconds to turn off the delay.

EXT or EXT1 is the front panel trigger input.

EXT2 is the rear panel trigger input.

Factory Preset: 0.0 s
Range: – 100.0 ms to 500.0 ms
Default Unit: seconds
Front Panel
Access: **Mode Setup, Trigger, Ext Rear (or Ext Front), Delay**

External Trigger Level

```
:TRIGger[:SEquence]:EXTernal[1]|2:LEvel <voltage>
:TRIGger[:SEquence]:EXTernal[1]|2:LEvel?
```

Set the trigger level when using an external trigger input.

EXT or EXT1 is the front panel trigger input

EXT2 is the rear panel trigger input

Factory Preset: 2.0 V
Range: – 5.0 to + 5.0 V
Default Unit: volts
Front Panel
Access: **Mode Setup, Trigger, Ext Rear (or Ext Front), Level**

External Trigger Slope

```
:TRIGger[:SEquence]:EXTernal[1]|2:SLOpe NEGative|POSitive
```

:TRIGger[:SEquence]:EXTernal[1|2]:SLOPe?

Sets the trigger slope of an external trigger input to either NEGative or POSitive.

EXT or EXT1 is the front panel trigger input.

EXT2 is the rear panel trigger input.

Factory Preset: Positive

Front Panel

Access: **Mode Setup, Trigger, Ext Rear (or Ext Front), Slope**

Frame Trigger Adjust

:TRIGger[:SEquence]:FRAME:ADJust <time>

Lets you advance the phase of the frame trigger by the specified amount. It does not change the period of the trigger waveform. If the command is sent multiple times, it advances the phase of the frame trigger more each time it is sent.

Factory Preset: 0.0 s

Range: 0.0 to 10.0 s

Default Unit: seconds

Front Panel

Access: None

Frame Trigger Period

:TRIGger[:SEquence]:FRAME:PERiod <time>

:TRIGger[:SEquence]:FRAME:PERiod?

Set the frame period that you want when using the external frame timer trigger. If the traffic rate is changed, the value of the frame period is initialized to the preset value.

Factory Preset: 250.0 μ s for Basic, cdmaOne

4.615383 ms, for GSM

26.666667 ms for cdma2000 and 1xEV-DO

10.0 ms (1 radio frame) for W-CDMA

90.0 ms for iDEN (E4406A)

20.0 ms with rate=full for NADC, PDC

40.0 ms with rate=half for NADC, PDC

Range: 0.0 ms to 559.0 ms for Basic, cdmaOne, GSM,

cdma2000, W-CDMA, 1xEV-DO

1.0 ms to 559.0 ms for iDEN (E4406A), NADC, PDC

Default Unit: seconds

Front Panel

Access: **Mode Setup, Trigger, Frame Timer, Period**

Frame Trigger Sync Source

:TRIGger[:SEQuence]:FRAMe:SYNC EXTFront|EXTRear|OFF

:TRIGger[:SEQuence]:FRAMe:SYNC?

Selects the input port location for the external frame trigger that you are using.

Factory Preset: Off

Remarks: You must be in the Basic, cdmaOne, EDGE (w/GSM), GSM, iDEN (E4406A), NADC, PDC, Service mode to use this command. Use INSTRument:SElect to set the mode.

Front Panel

Access: **Mode Setup, Trigger, Frame Timer, Sync Source**

History Changed firmware revision A.05.00.

Frame Trigger Synchronization Offset

:TRIGger[:SEQuence]:FRAMe:SYNC:OFFSet <time>

:TRIGger[:SEQuence]:FRAMe:SYNC:OFFSet?

Lets you adjust the frame triggering with respect to the external trigger input that you are using.

Factory Preset: 0.0 s

Range: 0.0 to 10.0 s

Default Unit: seconds

Remarks: You must be in the Basic, cdmaOne, GSM, EDGE, iDEN (E4406A), NADC, PDC, Service mode to use this command. Use INSTRument:SElect to set the mode.

History: Revision A.03.27 or later

Front Panel

Access: **Mode Setup, Trigger, Frame Timer, Offset**

Trigger Holdoff

`:TRIGger[:SEquence]:HOLDoff <time>`

`:TRIGger[:SEquence]:HOLDoff?`

Set a value of the holdoff time between triggers. After a trigger, another trigger will not be allowed until the holdoff time expires. This parameter affects all trigger sources.

Factory Preset: 0.0 s

20.0 ms for iDEN (E4406A)

10.0 ms for NADC or PDC

Range: 0.0 to 500.0 ms

Default Unit: seconds

Front Panel

Access: **Mode Setup, Trigger, Trigger Holdoff**

Video (IF) Trigger Delay

`:TRIGger[:SEquence]:IF:DElay <time>`

`:TRIGger[:SEquence]:IF:DElay?`

Set a value of the trigger delay of the IF (video) trigger (signal after the resolution BW filter).

Factory Preset: 0.0 s

Range: – 100.0 ms to 500.0 ms

Default Unit: seconds

Front Panel

Access: **Mode Setup, Trigger, Video (IF Envlp), Delay**

Video (IF) Trigger Level

`:TRIGger[:SEquence]:IF:LEvel <ampl>`

`:TRIGger[:SEquence]:IF:LEvel?`

Set the trigger level when using the IF (video) trigger.

Factory Preset: – 6.0 dBm for cdmaOne, GSM, EDGE, Basic, Service (E4406A), cdma2000, W-CDMA, 1xEV-DO
 – 20.0 dBm for iDEN (E4406A)
 – 30.0 dBm for NADC, PDC

Range: – 200.0 to 50.0 dBm

Default Unit: dBm

Front Panel
 Access: **Mode Setup, Trigger, Video (IF Envlp), Level**

Video (IF) Trigger Slope

`:TRIGger[:SEquence]:IF:SLOPe NEGative|POSitive`

`:TRIGger[:SEquence]:IF:SLOPe?`

Sets the trigger slope when using the IF (video) trigger, to either NEGative or POSitive.

Factory Preset: Positive

Front Panel

Access: **Mode Setup, Trigger, Video (IF Envlp), Slope**

RF Burst Trigger Delay

`:TRIGger[:SEquence]:RFBurst:DElay <time>`

`:TRIGger[:SEquence]:RFBurst:DElay?`

Set the trigger delay when using the RF burst (wideband) trigger.

Factory Preset: 0.0 μ s

Range: – 100.0 ms to 500.0 ms

Default Unit: seconds

Front Panel

Access: **Mode Setup, Trigger, RF Burst, Delay**

RF Burst Trigger Level

`:TRIGger[:SEquence]:RFBurst:LEvel <rel_power>`

`:TRIGger[:SEquence]:RFBurst:LEvel?`

Set the trigger level when using the RF Burst (wideband) Trigger. The

value is relative to the peak of the signal. RF Burst is also known as RF Envelope.

Factory Preset: – 6.0 dB

Range: – 25.0 to 0.0 dB
– 200.0 to 0.0 dB for NADC, PDC

Default Unit: dB

Front Panel

Access: **Mode Setup, Trigger, RF Burst, Peak Level**

RF Burst Trigger Slope

`:TRIGger[:SEQuence]:RFBurst:SLOPe NEGative|POSitive`

`:TRIGger[:SEQuence]:RFBurst:SLOPe?`

Set the trigger slope when using the RF Burst (wideband) Trigger.

Factory Preset: Positive

Remarks: You must be in the cdmaOne, cdma2000, W-CDMA mode to use this command. Use `:INSTrument:SElect` to set the mode.

Front Panel

Access: **Mode Setup, Trigger, RF Burst, Slope**

5 Concepts

This chapter provides details about the cdmaOne communications system, and explains how the various measurements are performed by the instrument. Suggestions for optimizing and troubleshooting your setup are provided, along with a list of related Agilent documents that are referenced for further information.

What Is the cdmaOne (IS-95) Communication System?

Code Division Multiple Access (CDMA) is a direct sequence spread-spectrum digital communications technique that was originally designed for military applications. The main advantages of CDMA over other types of communications schemes are:

- greater capacity than with other techniques
- immunity to signal loss and degradation in the presence of high broadband interference
- immunity to signal loss and degradation due to multipath, scatter, and fading
- power consumption of mobile stations is strictly minimized (by base station control)
- supports full 9600 baud capability for voice and data communications
- provides increased security

CDMA uses correlative codes to distinguish one user from another. Frequency division is still used, as is done with Frequency Division Multiple Access (FDMA) and Time Division Multiple Access (TDMA), but in a much larger bandwidth (1.25 MHz). CDMA uses a direct sequence spread spectrum technique that realizes increased capacity from 1:1 frequency reuse and sectored cells. The capacity limit is soft. That is, capacity can be increased with some degradation of the error rate or voice quality.

In cdmaOne, a single user's channel consists of a specific frequency combined with a unique code. Correlative codes allow each user to operate in the presence of substantial interference. The interference is the sum of all other users on the same cdmaOne frequency, both from within and without the home cell, and from delayed versions of these signals. It also includes the usual thermal noise and atmospheric disturbances. Delayed signals caused by multipath are separately received and combined in cdmaOne. One of the major differences in access, compared to a non-cdma system, is that any cdmaOne frequency can be used in all sectors of all cells. This is possible because cdmaOne is designed to decode the proper signal in the presence of high interference.

The cdmaOne communication system is defined in the following Electronics Industry Association (EIA) and Telecommunications Industry Association (TIA) documents:

TIA/EIA/

IS-95-A

Mobile Station - Base Station Compatibility Standard for Dual-Mode Wideband Spread Spectrum Cellular System

TIA/EIA-97-B Recommended Minimum Performance Standards for Base Stations Supporting Dual-Mode Wideband Spread Spectrum Cellular Mobile Stations

TIA/EIA-98-B Recommended Minimum Performance Standards for dual-Mode Wideband Spread Spectrum Cellular Mobile Stations

And the following American National Standards Institute (ANSI) documents:

J-STD-008 Personal Station-Base Station Compatibility Requirements for 1.8 to 2.0 GHz Code Division Multiple Access (CDMA) Personal Communications Systems

J-STD-018 Recommended Minimum Performance Requirements for 1.8 to 2.0 GHz Code Division Multiple Access (CDMA) Personal Stations

J-STD-019 Recommended Minimum Performance Requirements for Base Stations Supporting 1.8 to 2.0 GHz Code Division Multiple Access (CDMA) Personal Stations

Channel Power Measurement Concepts

Purpose

The Channel Power measurement is a common test used in the wireless industry to measure the total transmitted power of a radio within a defined frequency channel. This procedure measures the total power within the defined channel for cdmaOne. This measurement is applied to design, characterize, evaluate, and verify transmitters and their components or devices for base stations and mobile stations.

Measurement Method

The Channel Power measurement reports the total transmitted power within the channel bandwidth, 1.23000 MHz for the cdmaOne mode. The measurement acquires a number of points representing the input signal in the time domain. It transforms this information into the frequency domain using FFT and then calculates the channel power. The effective resolution bandwidth of the frequency domain trace is proportional to the number of points acquired for FFT. The fastest FFT process is achieved using a number of acquired points that is a power of 2 (for example: 64, 128, 512).

Since the measurement is optimized for speed and accuracy, you are permitted to change only the number of acquired data points in powers of 2, not the actual resolution bandwidth which is shown in gray. However, if absolute sweep time is required, it can be changed to the user's specific value at the expense of reduced speed. At no time will both sweep time and data points be set to manual because of conflicting parameter settings. This flexibility is available through the **Advanced** menu of the channel power measurement.

To improve repeatability, you can increase either the number of averages or the number of data points with longer time record length. The channel power graph is shown in the graph window, while the absolute channel power in dBm and the mean power spectral density in dBm/Hz are shown in the text window.

Modulation Accuracy (Rho) Measurement Concepts

Purpose

Rho is one of the key modulation quality metrics, along with EVM and code domain power. Rho is the ratio of the correlated power in a single coded channel to the total signal power. This is a simplified case of code domain power since this measurement is made on a single coded channel. This measurement takes into account all possible error mechanisms in the entire transmission chain including baseband filtering, I/Q modulation anomalies, filter amplitude and phase non-linearities, and power amplifier distortion. This provides an overall indication of the performance level of the transmitter of the UUT.

Measurement Method

This procedure measures the performance of the transmitter's modulation circuitry.

The instrument can perform base station and mobile measurements. In both cases the transmitter's modulated signal is compared to an ideal reference waveform. Rho values are in the range of 0 to 1. A value of 1 indicates perfect correlation to the reference (high modulation quality).

The cdmaOne base station standards require that transmitters have a Rho performance of 0.912 or greater.

When performing mobile testing with the Rho measurement, the phone must be placed in a test mode to modulate only the known short code sequences in the reverse link. The measurement will not work with a live phone call on which data is being modulated.

The following data are provided by the Rho measurement:

- Rho - modulation quality
- Time Offset - how well your transmitter's signal is time-aligned to system time
- Frequency Error - the frequency difference between your transmitter's actual center frequency and the frequency (or channel) that you entered
- Carrier Feedthrough - measures the performance of the I/Q modulator of your transmitter
- EVM - rms Error Vector Magnitude
- Mag Error - rms Magnitude Error
- Phase Error - rms Phase Error

Code Domain Measurement Concepts (Base Station Only)

Purpose

The code domain measurement displays the power for each of the 64 Walsh channels, relative to the total power inside a 1.23 MHz bandwidth centered at the Center Frequency. Each Walsh channel level is displayed as an individual vertical bar. Because this is a relative measurement, the unit of measure is dB (not dBm or watts). This allows a comparison of signal levels between the Pilot, Sync, Paging, and Traffic channels.

Measurement Method

This procedure measures the power, timing, and phase of the 64 Walsh channels in a single RF channel. The measurement method can be selected to either measure just code domain power, or to measure code domain power, timing, and phase. The measurement runs faster when measuring only code domain power.

Code Domain Phase

Code Domain Phase displays the phase error for each of the 64 Walsh channels relative to the Pilot channel. Displays above the zero reference in the center of the screen indicate that the Walsh channel leads the Pilot channel; displays below the zero reference in the center of the screen indicate that the Walsh channel lags the Pilot channel. Move the marker to read the phase for each individual channel.

Code Domain Timing

Code Domain Timing displays the time offset for each of the 64 Walsh channels relative to the Pilot channel which is Walsh code zero. Displays above the reference indicate that the Walsh channel leads the Pilot channel; displays below the zero reference indicate that the Walsh channel lags the Pilot channel. Move the marker to read the Timing for each individual channel

Time Offset

Time Offset indicates how well your transmitter's signal is time-aligned to system time. The displayed value takes into account the PN Sequence Offset Index of your transmitter that is entered using the **PN Offset** key

Frequency Error

Frequency Error is the frequency difference between your transmitter's actual center frequency and the frequency (or channel) that you entered.

Carrier Feedthrough

Carrier Feedthrough is used to measure the performance of the I/Q modulator of your transmitter. Extremely low values indicate a very good I/Q modulator. Higher values indicate potential problems with the I/Q modulator. If Carrier Feedthrough measures higher than approximately -20 dBc, there may be problems with the base station.

Avg AT	Average Active Traffic Power of all active Walsh channels. A Walsh channel is considered active if its power is above the value set by the Active Set Th key.
Max IT	Maximum Inactive Traffic power of all inactive Walsh channels.
Avg IT	Average Inactive Traffic power of any inactive Walsh channel.

Spur Close Measurement Concepts

Purpose

This procedure measures the spurious emissions in the transmit band relative to channel power in the selected channel. The unit under test is typically set for maximum output power. The measurement can be used when the unit under test is set for output power less than maximum, however the limits used might not be correct.

Measurement Method

The transmit band spectrum is measured in several frequency segments using resolution bandwidths as specified by the standard. The channel power (integrated power in a 1.23 MHz bandwidth) is measured first, and then used as a reference for the measurement limit lines. The spectrum, centered around the carrier as well as above and below the carrier, is then measured. For each spectrum segment, the measurement looks for the spectrum peak closest to the limit and reports it as the **Worst Spur**. The amplitude difference from peak to the limit line (Δ from Limit), the frequency difference from the peak to the center of the channel (Offset Freq), and the amplitude difference from the peak to the channel power (Δ from Carrier) are displayed. If the peak goes above the limit line, the display will indicate **FAIL**. If **Marker** is on, the active marker is placed at the worst spur of the displayed segment.

Table 5-1 Spurious Emission Limits When Transmitting

Band	Device	Offset Frequency	Limit
IS-95A	Base	>750 kHz	- 45 dBc/30 kHz
		>1.980 MHz	- 60 dBc/30 kHz
		outside channel's band but inside Tx band	- 13 dBm/30 kHz or - 60 dBc/30 kHz, whichever is smaller
		outside Tx band	- 13 dBm/100 kHz
	Mobile	>885 kHz	- 42 dBc/30 kHz
		>1.980 MHz	- 54 dBc/30 kHz
		outside channel's band but inside Tx band	- 54 dBm/30 kHz
		outside Tx band	- 13 dBm/100 kHz

Table 5-1 Spurious Emission Limits When Transmitting

Band	Device	Offset Frequency	Limit
J-STD-008	Base	>885 kHz	– 45 dBc/30 kHz
		≤1 MHz outside & adjacent to the channel's band	– 13 dBm/12.5 kHz or – 80 dBc/12.5 kHz, whichever is greater
		>1 MHz outside channel's band but inside Tx band	– 13 dBm/1 MHz or – 80 dBc/1 MHz, whichever is greater
		outside Tx band	– 13 dBm/1 MHz
	Mobile	>1.265 MHz	– 42 dBc/30 kHz
		≤1 MHz outside & adjacent to the channel's band	– 13 dBm/12.5 kHz
		>1 MHz outside channel's band but inside Tx band	– 13 dBm/1 MHz
		outside Tx band	– 13 dBm/1 MHz
IS-97D IS-98D Band Class 0 or 3	Base	765 kHz to 1.995 MHz	– 45 dBc/30 kHz
		1.995 MHz to 4.015 MHz	– 60 dBc/30 kHz at ≥33 dBm – 27 dBm/30 kHz at 28 dBm – 55 dBc/30 kHz at <28 dBm
		4.050 MHz to 14.000 MHz ^a	– 13 dBm/100 kHz Category A – 36 dBm/100 kHz Category B
	Mobile	900 kHz to 1.995 MHz	– 42 dBc/30 kHz or – 70.13 dBm/30 kHz whichever is greater
		1.995 MHz to 4.015 MHz	– 54 dBc/30 kHz or – 70.13 dBm/30 kHz, whichever is greater
		4.050 MHz to 14.000 MHz ^a	– 13 dBm/100 kHz Category A – 36 dBm/100 kHz Category B

Table 5-1 Spurious Emission Limits When Transmitting

Band	Device	Offset Frequency	Limit
IS-97D IS-98D Band Class 1 or 4	Base	900 kHz to 1.265 MHz	- 45 dBc/30 kHz
		1.265 MHz to 1.995 MHz	- 45 dBc/30 kHz or - 9 dBm/30 kHz, whichever is smaller
		1.995 MHz to 2.265 MHz	- 55 dBc/30 kHz at ≥33 dBm - 22 dBm/30 kHz at 28 dBm - 50 dBc/30 kHz at <28 dBm
		2.750 MHz to 4.500 MHz	- 13 dBm/1 MHz
		4.500 MHz to 14.000 MHz ^a	- 13 dBm/1 MHz Category A - 30 dBm/1 MHz Category B
	Mobile	1.265 MHz to 1.995 MHz	- 42 dBc/30 kHz or - 70.13 dBm/30 kHz, whichever is greater
		1.995 MHz to 4.015 MHz	- 50 dBc/30 kHz or - 70.13 dBm/30 kHz, whichever is greater
		4.050 MHz to 14.000 MHz ^a	- 13 dBm/1 MHz Category A - 30 dBm/1 MHz Category B

a. applicable if the measurement span is 10 MHz.

Spectrum (Frequency Domain) Measurement Concepts

Purpose

The spectrum measurement provides spectrum analysis capability for the instrument. The control of the measurement was designed to be familiar to those who are accustomed to using swept spectrum analyzers.

This measurement is FFT (Fast Fourier Transform) based. The FFT-specific parameters are located in the **Advanced** menu. Also available under basic mode spectrum measurements is an I/Q window, which shows the I and Q signal waveforms in parameters of voltage versus time. The advantage of having an I/Q view available while in the spectrum measurement is that it allows you to view complex components of the same signal without changing settings or measurements.

Measurement Method

The measurement uses digital signal processing to sample the input signal and convert it to the frequency domain. With the instrument tuned to a fixed center frequency, samples are digitized at a high rate, converted to I and Q components with DSP hardware, and then converted to the frequency domain with FFT software.

Troubleshooting Hints

Changes made by the user to advanced spectrum settings, particularly to ADC range settings, can inadvertently result in spectrum measurements that are invalid and cause error messages to appear. Care needs to be taken when using advanced features.

Waveform (Time Domain) Measurement Concepts

Purpose

The waveform measurement is a generic measurement for viewing the input signal waveforms in the time domain. This measurement is how the instrument performs the zero span functionality found in traditional spectrum analyzers.

Basic mode waveform measurement data may be displayed using either a Signal Envelope window, or an I/Q window which shows the I and Q signal waveforms in parameters of voltage versus time. The advantage of having an I/Q view available while making a waveform measurement is that it allows you to view complex components of the same signal without changing settings or measurements.

The waveform measurement can be used to perform general purpose power measurements in the time domain with excellent accuracy.

Measurement Method

The instrument makes repeated power measurements at a set frequency, similar to the way a swept-tuned spectrum analyzer makes zero span measurements. The input analog signal is converted to a digital signal, which then is processed into a representation of a waveform measurement. The measurement relies on a high rate of sampling to create an accurate representation of a time domain signal.

Adjacent Channel Power Ratio (ACPR) Measurement Concepts

Purpose

Adjacent Channel Power Ratio (ACPR), as it applies to cdmaOne, is the power contained in a specified frequency channel bandwidth relative to the total carrier power. It may also be expressed as a ratio of power spectral densities between the carrier and the specified offset frequency band.

As a composite measurement of out-of-channel emissions, ACPR combines both in-band and out-of-band specifications to provide useful figures-of-merit for spectral regrowth and emissions produced by components and circuit blocks without the rigor of performing a full spectrum emissions mask measurement.

To maintain a quality call by avoiding channel interference, it is important to measure and reduce any adjacent channel leakage power transmitted from a mobile phone. The characteristics of adjacent channel leakage power are mainly determined by the transmitter design, particularly the low-pass filter.

Measurement Method

This ACPR measurement analyzes the total power levels within the defined carrier bandwidth and at given frequency offsets on both sides of the carrier frequency. This measurement requires the user to specify measurement bandwidths of the carrier channel and each of the offset frequency pairs up to 5. Each pair may be defined with unique measurement bandwidths.

It uses an integration bandwidth (IBW) method that performs a time domain data acquisition and applies FFT to get a frequency domain trace. In this process, the channel integration bandwidth is analyzed using the automatically defined resolution bandwidth (RBW), which is much narrower than the channel bandwidth. The measurement computes an average power of the channel over a specified number of data acquisitions, automatically compensating for resolution bandwidth and noise bandwidth.

If **Total Pwr Ref** is selected as the measurement type, the results are displayed as relative power in dBc and as absolute power in dBm. If **PSD Ref** (Power Spectral Density Reference) is selected, the results are displayed as relative power in dB, and as absolute power in dBm/Hz.

Recommended Offset Frequencies and Reference Bandwidths

While the user sets the specific offsets and reference bandwidths, the

radio specifications recommend some common setups as shown in the following table. The offset frequency is titled as *Offset to Edge* in the measurement result window when Radio is set to IS-97D IS-98D. For example, if the measurement bandwidth is set to 30 kHz, the first offset center frequency can be 765 kHz and the offset to edge frequency can be 750 kHz.

Table 5-2 ACPR Setup Recommendation

Band	Test Device	Offset Frequency	Integration Bandwidth	Result Reference
cdmaOne IS-95A	Base	±750.0 kHz	30 kHz	PSD Ref
		±1.980 MHz	30 kHz	
	Mobile	±885.0 kHz	30 kHz	Total Power in 1.23 MHz
		±1.980 MHz	30 kHz	
cdmaOne J-STD-008	Base	±885.0 kHz	30 kHz	Total Power in 1.23 MHz
		±1.25625 MHz	12.5 kHz	
		±2.750 MHz	1.00 MHz	
	Mobile	±1.265 MHz	30 kHz	
		±1.750 MHz	1.00 MHz	
cdmaOne IS-97D IS98D Band Class 0 or 3	Base	±765.0 kHz	30 kHz	PSD Ref
		±1.995 MHz	30 kHz	
	Mobile	±900.0 kHz	30 kHz	Total Power in 1.23 MHz
		±1.995 MHz	30 kHz	
cdmaOne IS97D IS98D Band Class 1 or 4	Base	±900.0 kHz	30 kHz	Total Power in 1.23 MHz
		±1.265 MHz	30 kHz	
		±1.995 MHz	30 kHz	
		±2.750 MHz	1.00 MHz	
	Mobile	±1.265 MHz	30 kHz	
		±1.995 MHz	30 kHz	

Other Sources of Measurement Information

Additional measurement application information is available through your local Agilent sales and service office. The following application notes treat digital communications measurements in much greater detail than discussed in this measurement guide.

- Digital Modulation in Communications Systems - An Introduction
Application Note 1298
Part number 5965-7160E
- Understanding CDMA Measurements for Base Stations and Their Components
Application Note 1311
Part number 5968-0953E
- HPSK Spreading for 3GPP
Application Note 1335
Part number 5968-8438E
- cdma2000 - Mobile Stations
Application Note
Part number 5980-1237E
- cdma2000 - Base Stations
Application Note
Part number 5980-1303E
- 3GPP W-CDMA - Base Stations
Application Note
Part number 5980-1239E
- 3GPP W-CDMA - User Equipment
Application Note
Part number 5980-1238E
- Designing and Testing cdma2000 Base Stations
Application Note 1357
Part number 5980-1303E
- Optimizing Your GSM Network Today and Tomorrow
Application Note 1325
Part number 5980-2828EN
- Characterizing Digitally Modulated Signals with CCDF Curves
Application Note
Part number 5968-6875E
- E4406A Self-Guided Demo
Product Note
Part number 5968-7617E

Instrument Updates at www.agilent.com

These web locations can be used to access the latest information about the instrument, including the latest firmware version.

<http://www.agilent.com/find/psa>

<http://www.agilent.com/find/vsa>

6

Menu Maps

These menu maps are in alphabetical order by the front panel key label or oval cross-reference label. You can locate detailed information about each key/function at the page number listed in the figure title for each menu.

cdmaOne Measurement Key Flow

The key flow diagrams, shown in a hierarchical manner on the following pages, will help the user to grasp the overall functional relationships for the front-panel keys and the softkeys displayed at the extreme right side of the screen. The diagrams are:

- “ACPR Measurement Key Flow (1 of 2)” on page 359
- “Channel Power Measurement Key Flow” on page 361
- “Code Domain Measurement Key Flow (1 of 2)” on page 362
- “Mode Setup/Frequency Channel Key Flow (1 of 2)” on page 364
- “Modulation Accuracy (Rho) Measurement Key Flow” on page 366
- “Spectrum (Freq Domain) Measurement Key Flow (1 of 3)” on page 367
- “Spur Close Measurement Key Flow” on page 370
- “Waveform (Time Domain) Measurement Key Flow (1 of 2)” on page 371

Use these flow diagrams as follows:

- There are some basic conventions:

Meas Setup

An oval represents one of the front-panel keys.

I/Q Error (Quad View)

This box represents one of the softkeys displayed.

<Bot for EVM>

This represents an explanatory description on its specific key.

Avg Number 20 On|Off

This box represents one of the default condition softkeys displayed. Default conditions are shown as much as possible with underlined parameters or values displayed on those softkey labels.

- Follow the measurement diagram from left to right and top to bottom.
- A single softkey may allow multiple choices. For example; the **Device** softkey reveals two choices, **Base** or **Mobile**. The underlined choice is the current state of the instrument. To change choices, press the softkey one time.
- When entering a numeric value of **FREQUENCY**, for example, use the numeric keypad and terminate the entry with the appropriate unit selection from the softkeys displayed.
- When entering a numeric value of **Slot (Std)**, for example, use the numeric keypad and terminate with the **Enter** front-panel key.
- Instead of using the numeric keypad to enter a value, it may be easier to use the RPG knob or **Up/Down** keys.

Figure 6-1 ACPR Measurement Key Flow (1 of 2)

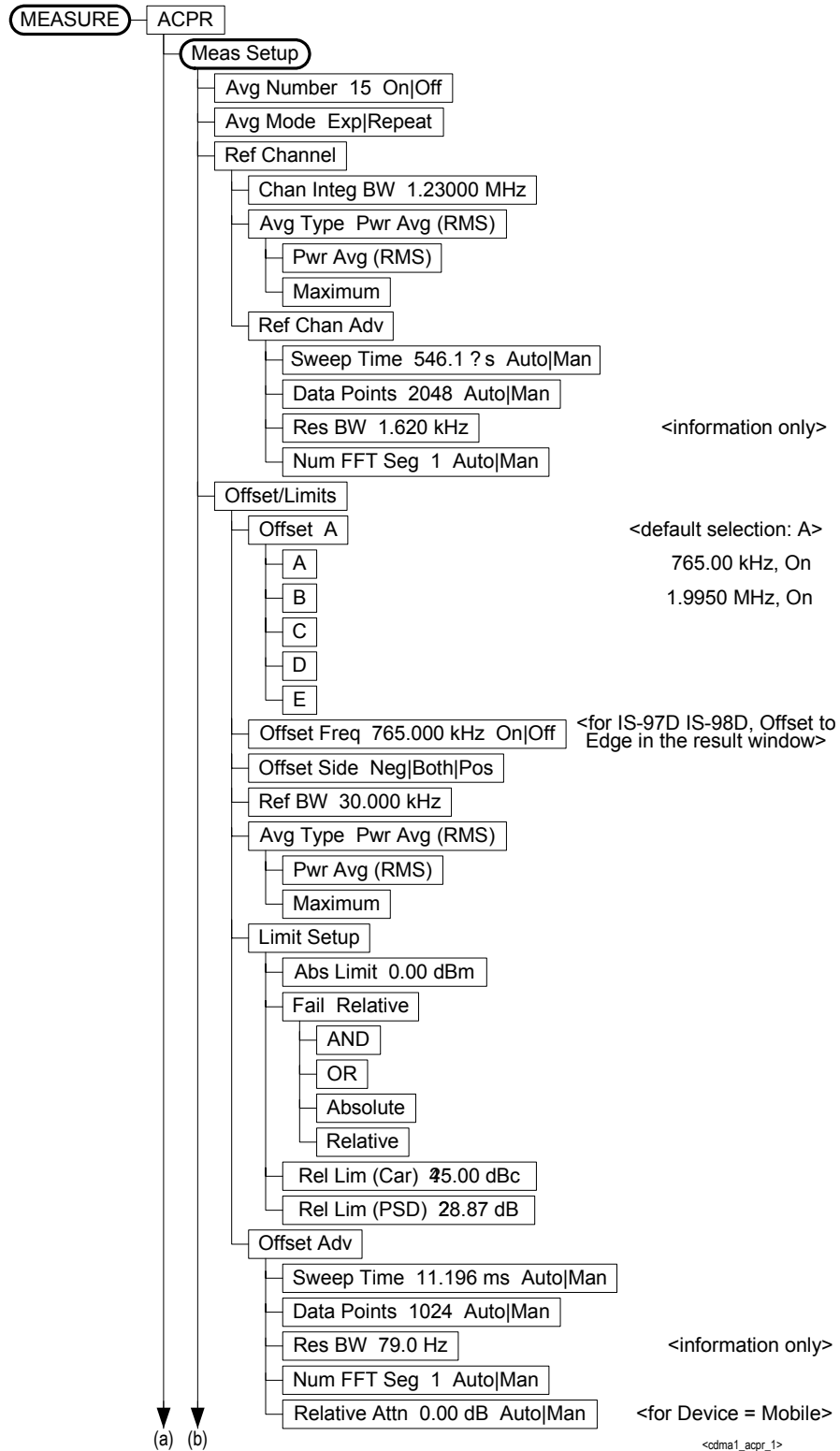

Figure 6-2 ACPR Measurement Key Flow (2 of 2)

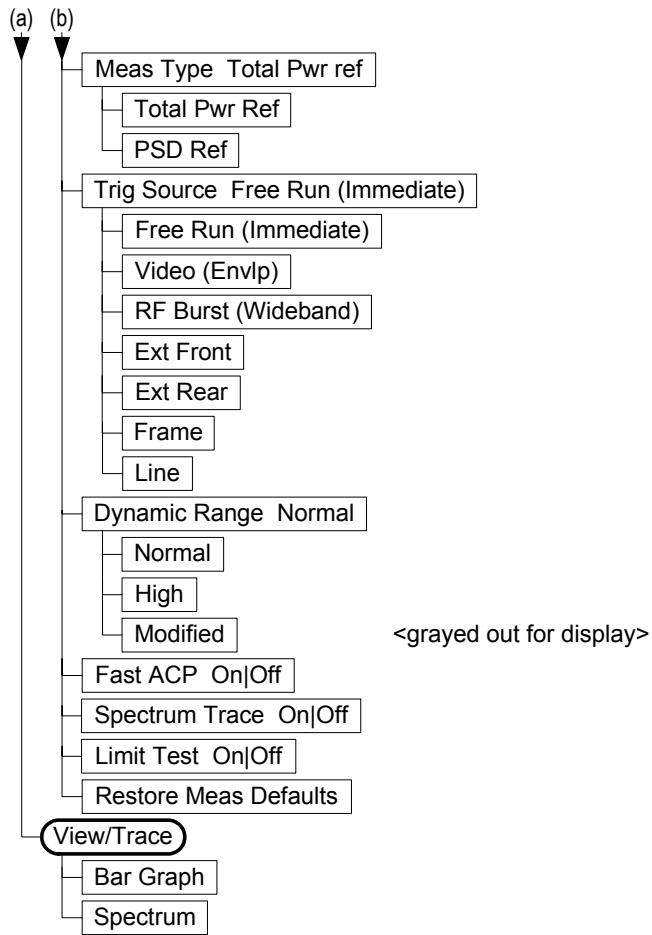
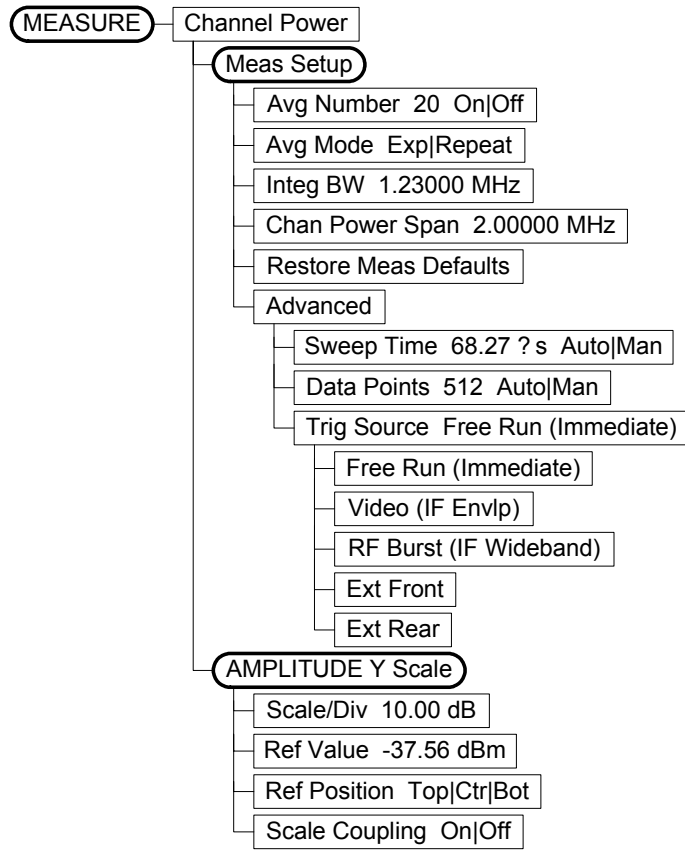
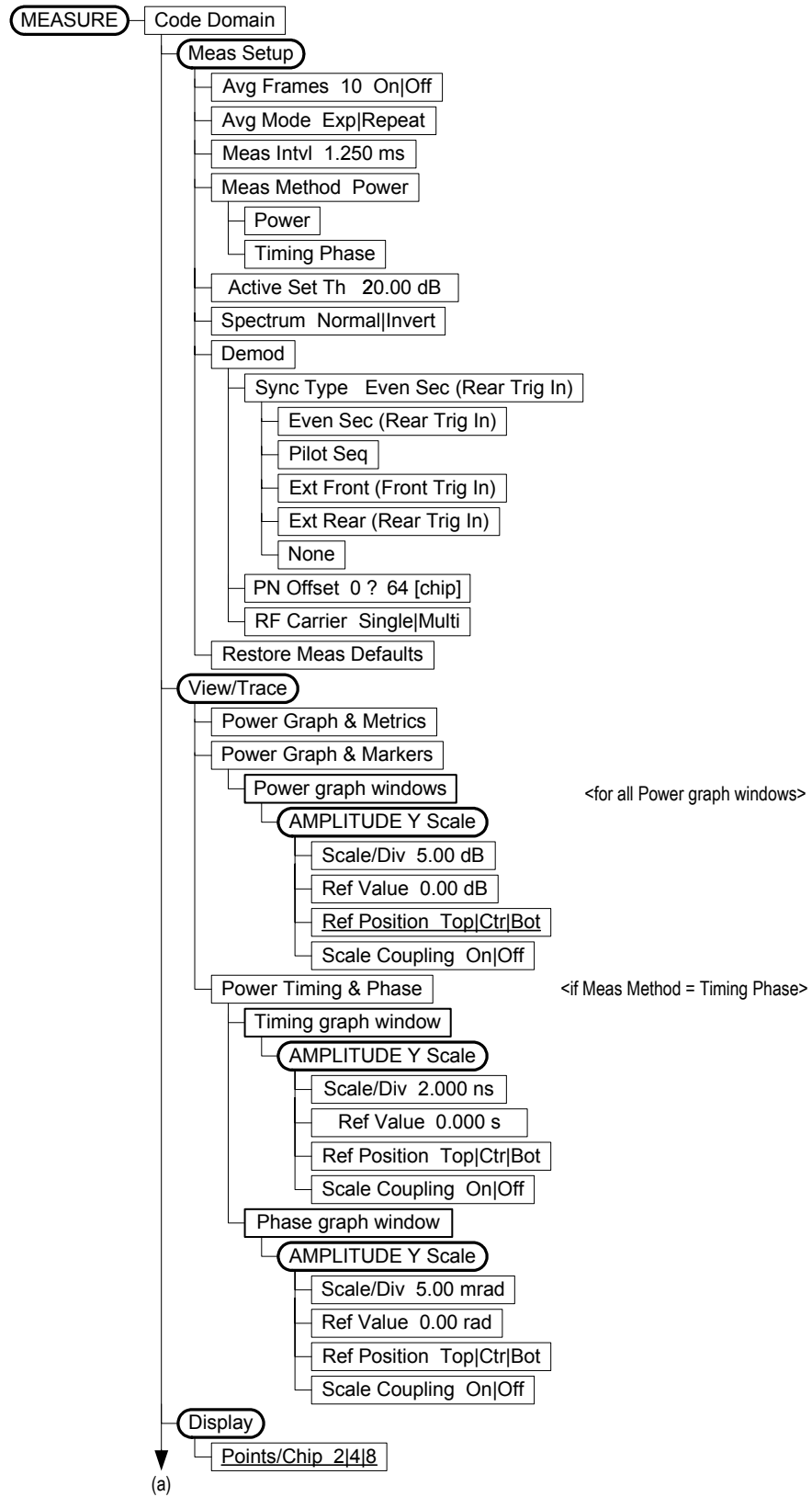

Figure 6-3 Channel Power Measurement Key Flow



<cdma1_chpwr_1>

Figure 6-4 Code Domain Measurement Key Flow (1 of 2)



(a)

<cdma1_cdp_1>

Figure 6-5 Code Domain Measurement Key Flow (2 of 2)

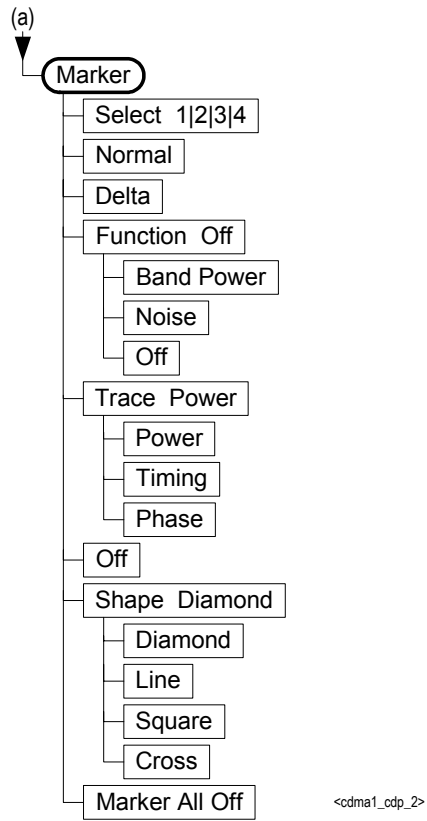

Figure 6-6 Mode Setup/Frequency Channel Key Flow (1 of 2)

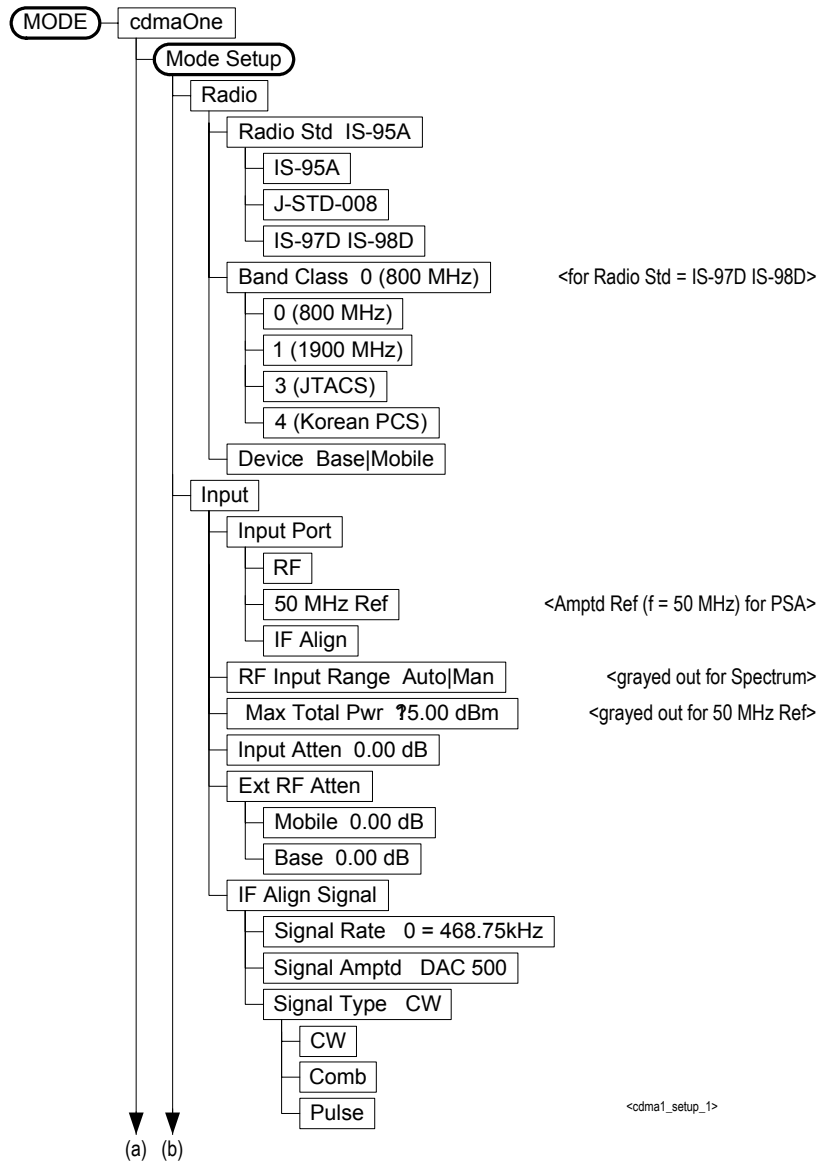
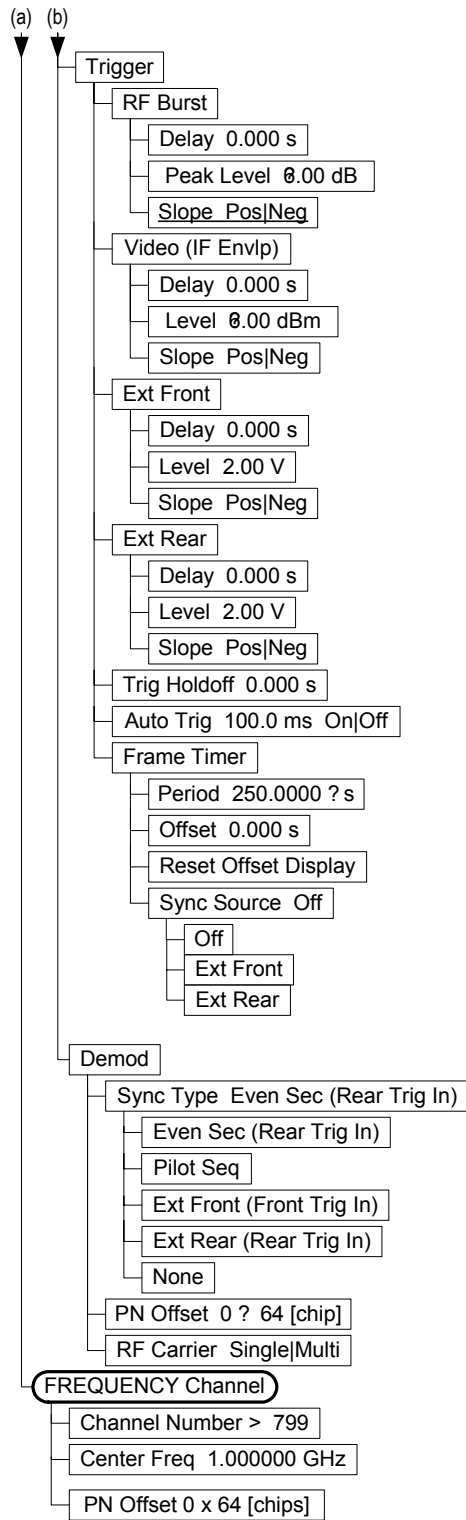
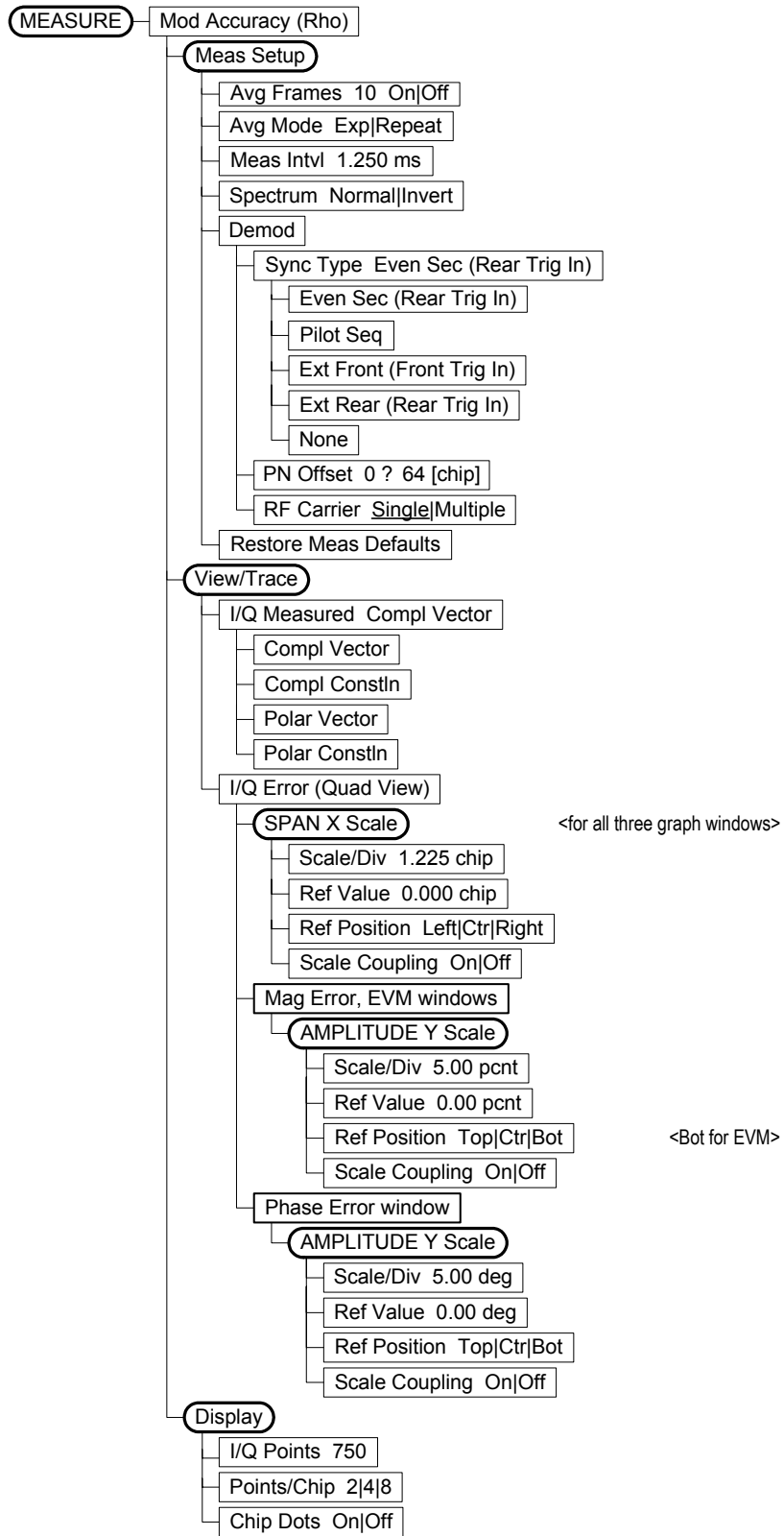

Figure 6-7 Mode Setup/Frequency Channel Key Flow (2 of 2)



<cdma1_setup_2>

Figure 6-8 Modulation Accuracy (Rho) Measurement Key Flow



<cdma1_rho_1>

Figure 6-9 Spectrum (Freq Domain) Measurement Key Flow (1 of 3)

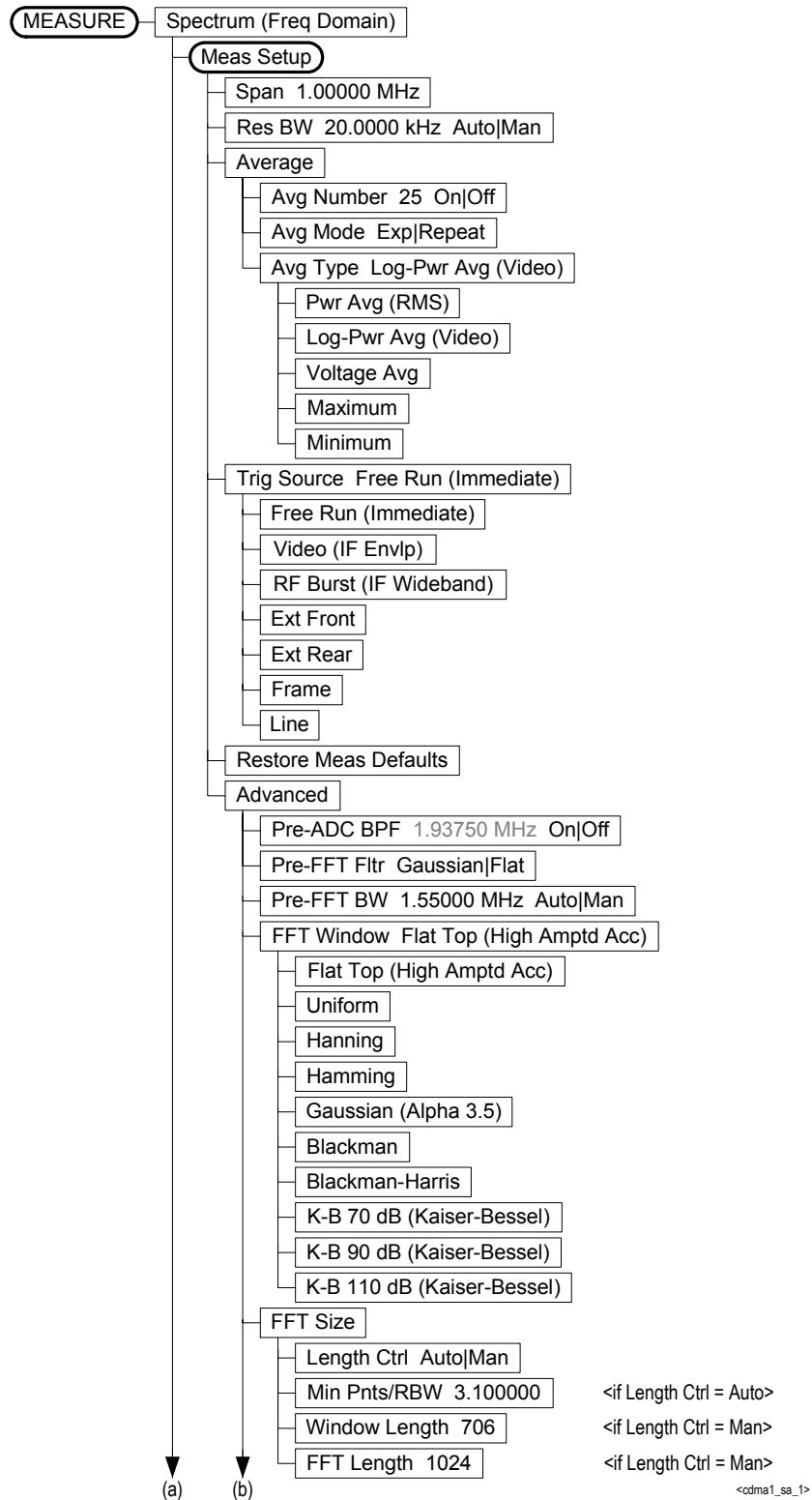

Figure 6-10 Spectrum (Freq Domain) Measurement Key Flow (2 of 3)

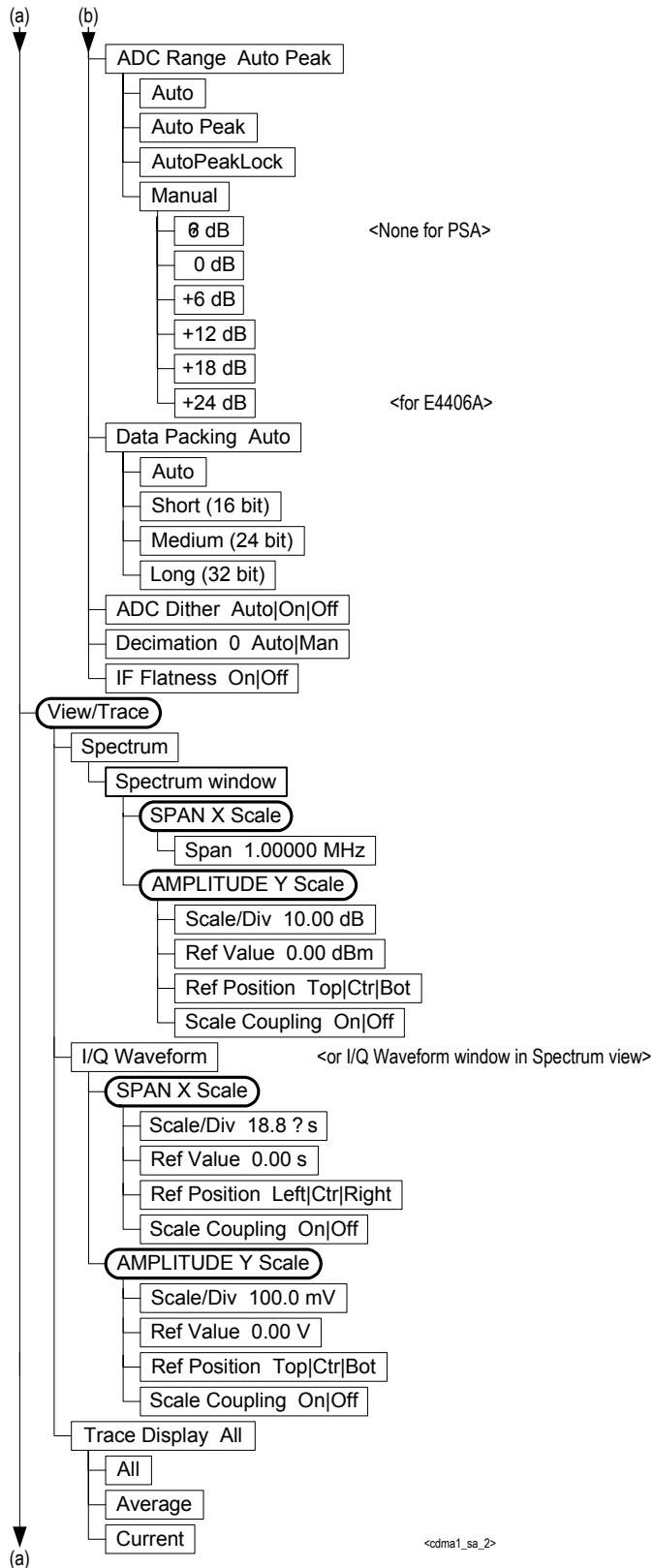

Figure 6-11 Spectrum (Freq Domain) Measurement Key Flow (3 of 3)

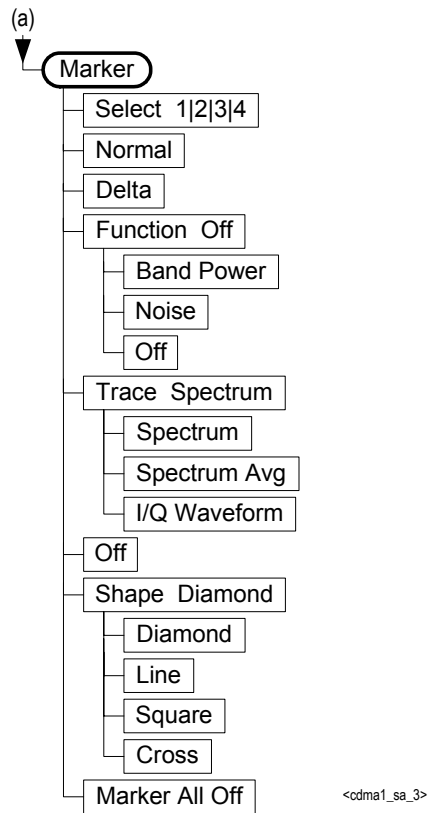

Figure 6-12 Spur Close Measurement Key Flow

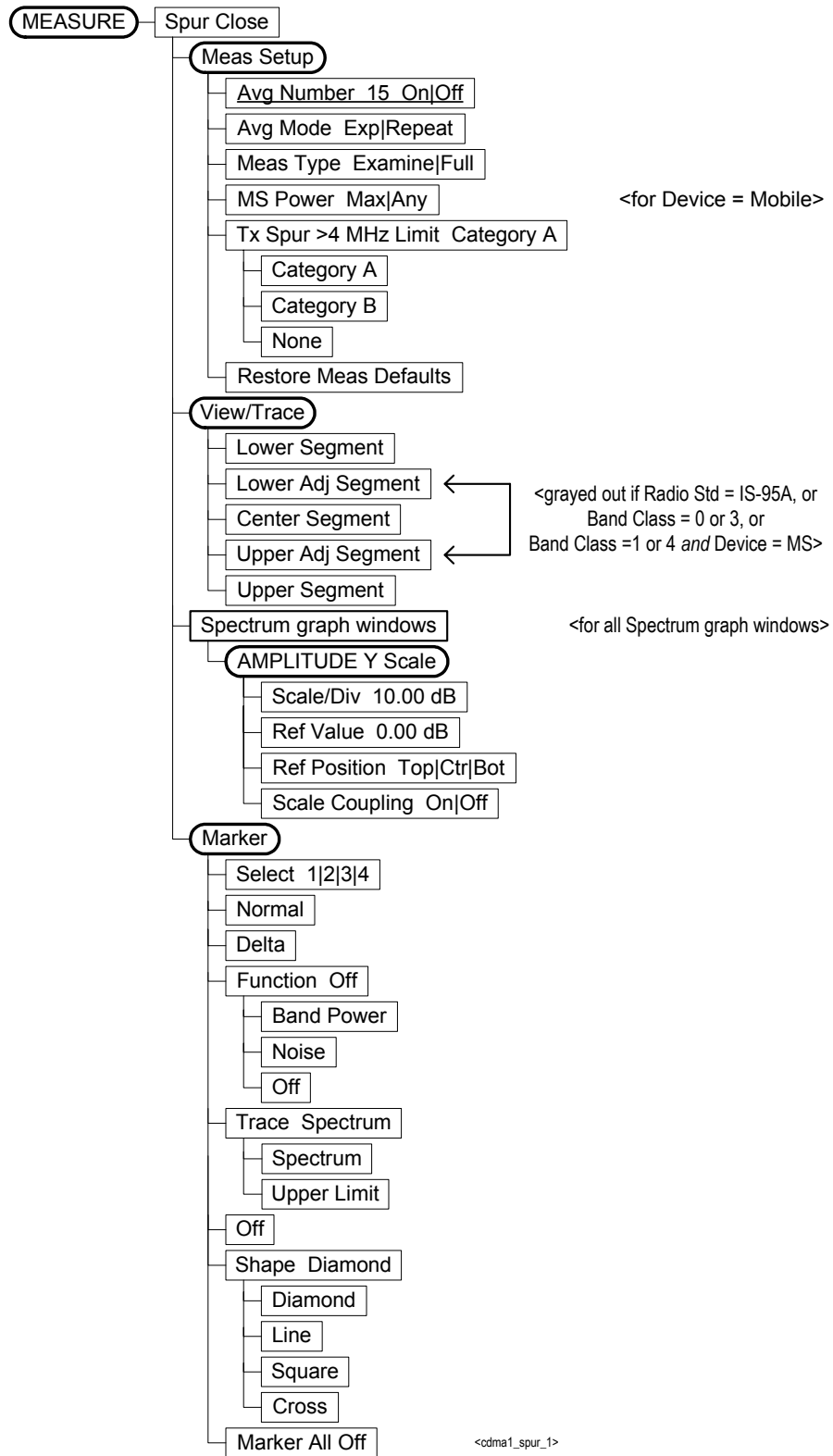

Figure 6-13 Waveform (Time Domain) Measurement Key Flow (1 of 2)

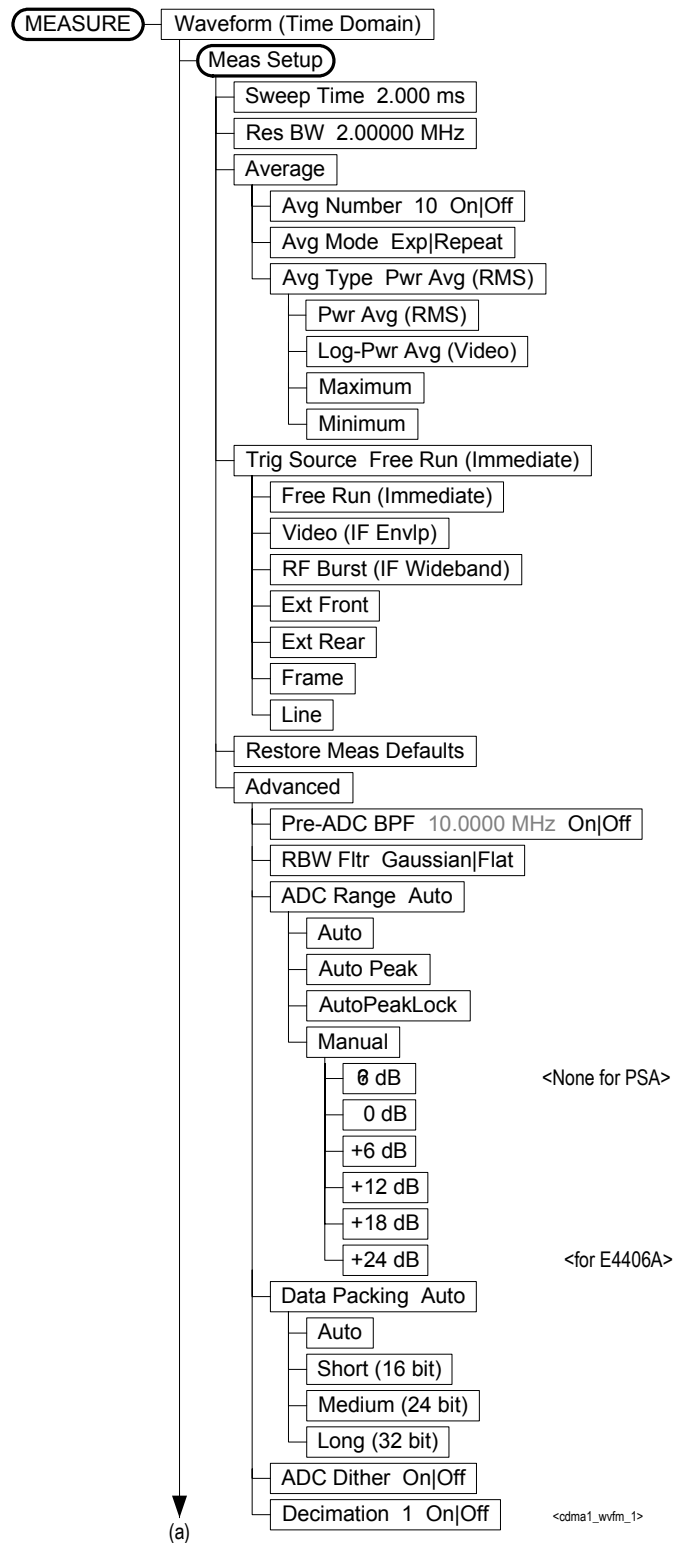
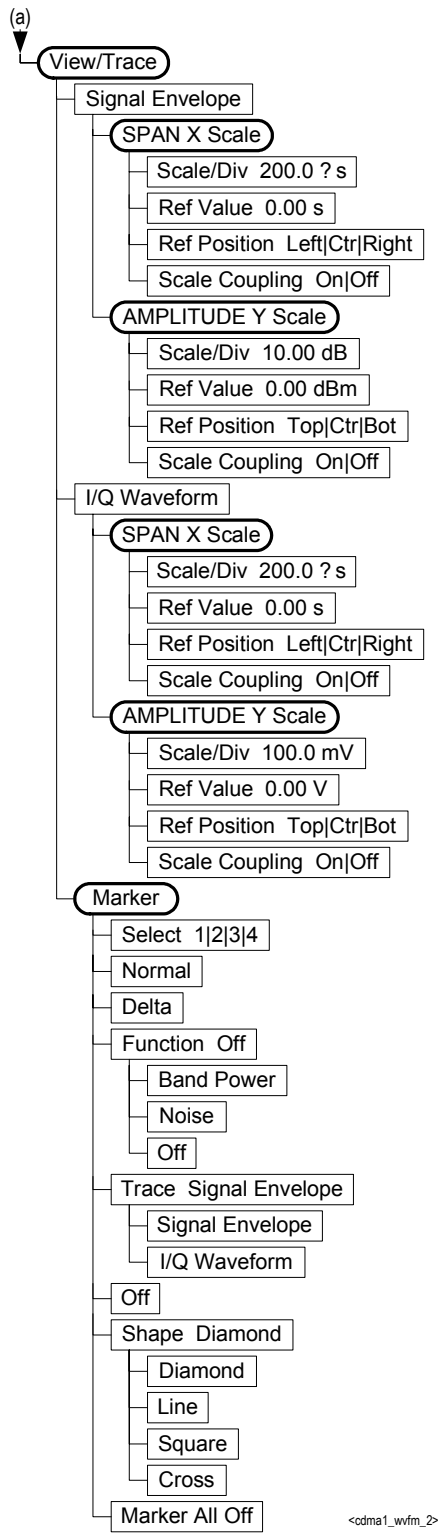

Figure 6-14 Waveform (Time Domain) Measurement Key Flow (2 of 2)



<cdma1_wfm_2>

A**ACP**

- averaging, 266, 271
- FFT, 269, 273, 274
- limit testing, 168
- offset frequencies, 271
- offset ref attenuation, 277, 278
- offset sideband choice, 281
- offset sweep time, 283, 288
- setting amplitude levels, 270
- testing, 269, 273, 274, 275, 276, 277, 278, 281, 283, 284, 286, 287, 288
- trigger source, 289
- view of data, 194

ACPR

- amplitude levels, 278, 280
 - averaging, 266, 271
 - measurement reference type, 104
 - offset frequencies, 274
 - resolution bandwidths, 272
 - sweep time, 288
 - swept mode res BW, 287
 - testing, 269, 273, 274
 - testing choices, 266, 271, 275, 276, 281, 282, 283, 287, 288, 290
 - view/trace selection, 106
- acquisition packing
 WAVEform, 326
- active channel threshold value, 293
- active license key, 27
 how to locate, 27
- ADC Corr key, 124, 145
- ADC Dither key
 spectrum measurement, 129
- ADC dithering
 SPECTrum, 312
 WAVEform, 326
- ADC filter
 WAVEform, 326
- ADC range
 SPECTrum, 313
 WAVEform, 327
- ADC Range key
 spectrum measurement, 128
- ADC ranging function
 automatic control, 149
 automatic peak control, 149
 automatic peak lock, 149
 manual control, 149
- adjacent channel power
 dynamic range, 268

- adjacent channel power
 measurement, 265, 269, 273, 274
- adjacent channel power ratio
 measurement, 218, 265
 See also ACPR
- Advanced menu
 spectrum, 127
 waveform
 waveform
 advanced settings, 148

advanced menu

- ADC dither, 149
 - ADC ranging function, 149
 - decimation, 149
 - number of data points, 109
 - pre-ADC bandpass filter, 148
 - resolution bandwidth, 109
 - resolution bandwidth filter, 149
 - sweep time, 109
 - trigger source, 109
- amplitude
 input range, 305
 maximizing input signal, 305
- amplitude Y scale
 reference position, 110, 115, 116, 121, 122
 reference value, 110, 115, 116, 121, 122
 scale coupling, 110, 115, 116, 121, 122
 scale per division, 110, 115, 116, 121

Analog Filter key, 124, 146**applications**

- currently available, 209
 - applications, selecting, 209, 211
- ARIBT53, 307, 308
- ASCII data format, 205
- attenuation
 setting, 305
- averaging
 ACP, 265, 266
 ACPR, 265, 266
 CDPower, 292
 CHPower, 295, 296
 CSPur, 301, 302
 modulation accuracy (rho), 309
 SPECTrum, 314, 315
 transmit band spurs, 291, 328
 WAVEform, 328, 329

B**bandwidth**

- ACPR, 267

- CHPower, 296
- SPECTrum, 318, 319
- WAVEform, 330, 331

base station

- loss correction, 300
- base station testing, 307
- basic mode, 89
- binary data order, 205
- Block Size key, 145
- burst trigger
 level, 339
- byte order of data, 205

C

- captured data block size
 (wideband IF), 145
- captured data sample rate
 (wideband IF), 145
- carrier selection, 307
- CDMA
 PN offset number, 294
- CDMA measurement, 242, 243, 265, 292, 295, 301, 308
- CDMA standards, 307, 308
- cdma2000
 ACP measurement, 270, 275, 276, 286, 287
 trigger source, 310
- cdma2000 measurement, 218, 244, 265
- cdmaOne
 ACP measurement, 270, 275, 276, 284, 286, 287
 trigger source, 310
- cdmaOne measurement, 218, 226, 244
- CDPower
 active set threshold value, 293
 measurement method, 293
 selecting spectrum type, 293
 sweep time, 294
- changing
 instrument settings, 265
- channel power
 advanced menu, 344
 amplitude Y scale, 110
 changing display, 110
 channel bandwidth, 344
 power spectral density, 344
 time record length, 344
- channel power measurement
 See also CHPower
- channel power measurement, 242, 295
- Choose Option key, 26
- CHPower
 number of points, 297

Index

- sweep time, 298
 - trigger source, 299
 - CKOR, 307, 308
 - close spurs measurement, 243, 301
 - See also CSPur
 - code domain
 - marker function
 - delta reading, 117
 - marker function, 117
 - marker selection, 116
 - normal reading, 116
 - off, 117
 - shape selection, 117
 - trace with marker, 117
 - marker functional markers off, 117
 - code domain power measurement, 226, 292
 - See also CDPower
 - code domain power measurement method, 293
 - code, programming
 - compatibility across PSA modes, 163, 165
 - compatibility, PSA series versus VSA, 166
 - commands
 - compatibility across PSA modes, 163, 165
 - CONFigure, 215
 - FETCh, 215
 - MEASure, 214
 - PSA series versus VSA
 - compatibility, 166
 - READ, 216
 - compatibility, programming
 - across PSA modes, 163
 - PSA series versus VSA, 166
 - CONFigure command use, 213
 - CONFigure commands, 215
 - continuous vs. single
 - measurement mode, 207
 - control measurement commands, 207
 - correction
 - base station loss, 300
 - mobile station loss, 300
 - corrections
 - wideband ADC corrections, 124, 145, 146
 - current measurement, 193
 - current measurement, query, 217
 - curve fit the data, 179
- D**
- data
 - querying, 169, 179
 - data block size, 145
 - data decimation, 319
 - WAVEform, 331, 332
 - data format, 205
 - data from measurements, 213
 - Data Packing
 - spectrum measurement, 129, 149
 - data sample rate, 145
 - Decimation
 - spectrum measurement, 129
 - decimation
 - SPECTrum, 319
 - decimation of data
 - WAVEform, 331, 332
 - default states, 36, 93
 - default values, setting remotely, 215
 - deleting an
 - application/personality, 21
 - delta markers, 185
 - display
 - spectrum window, 195, 196, 202, 203
 - tiling, 194
 - trace, 197
 - window tile, 194
 - zoom, 195
 - display ACP data, 194
 - display commands, 194
 - dithering of ADC
 - WAVEform, 326
 - dithering the ADC, 312
 - dynamic range
 - adjacent channel power, 268
- E**
- even second synchronization, 325
 - external trigger
 - delay, 335
 - level, 335
 - slope, 336
- F**
- FETCh command use, 213
 - FETCh commands, 215
 - FFT
 - SPECTrum, 320, 321, 322
 - FFT bandwidth, SPECTrum, 316, 317, 318
 - FFT Length key, 125, 128
 - FFT Size menu, 124, 128
 - FFT Window key., 124, 127
 - filter
 - gain setup (wideband), 123, 145
 - setup (wideband), 123, 145
 - type (wideband), 145
 - Filter Alpha key, 123, 145
 - Filter BW key, 123, 145
 - Filter Type key, 123, 145
 - Flat Top key, 123, 145
 - format, data, 205
 - frame trigger adjustment, 336, 337
 - frame trigger period, 336
 - frame trigger sync mode, 337
 - frequencies offset
 - ACP, 271
 - frequency
 - carrier setting, 307
 - frequency span
 - CHPower, 297
 - SPECTrum, 323
- G**
- Gaussian key, 123, 145
- I**
- I and Q waveform view
 - I or Q waveform window, 139
 - I waveform window, 158
 - Q waveform window, 158
 - I or Q waveform window
 - amplitude Y scale, 139
 - reference position, 139
 - reference value, 139
 - scale coupling, 139
 - scale per division, 139
 - span X scale
 - reference position, 137, 155
 - reference value, 137, 155
 - scale coupling, 138, 155
 - scale per division, 137, 155
 - I origin
 - I/Q polar window, 155, 156, 159
 - I Origin key, 138, 139
 - I waveform window
 - amplitude Y scale, 158
 - reference position, 159
 - scale coupling, 159
 - scale per division, 158
 - I/Q data output, 89
 - I/Q data results, 259, 262
 - I/Q error graphs
 - EVM graph
 - amplitude Y scale, 120, 121
 - magnitude error graph
 - amplitude Y scale, 120, 121
 - span X scale
 - reference position, 121
 - reference value, 120
 - scale coupling, 121
 - scale per division, 120

- I/Q Polar view
 - waveform measurement, 155, 159
 - I/Q polar view
 - I/Q polar window, 138, 139, 155, 159
 - I/Q polar window
 - amplitude Y scale, 139
 - I/Q scale per division, 138, 139
 - Q Origin, 138, 139
 - I origin, 155, 156, 159
 - I/Q scale per division, 155, 156, 159
 - Q origin, 155, 156, 159
 - span X scale, 138, 139
 - I Origin, 138, 139
 - I/Q scale per division
 - I/Q polar window, 155, 156, 159
 - I/Q Scale/Div key, 138, 139
 - I/Q waveform view
 - I/Q waveform window, 158
 - I/Q waveform window, 155
 - amplitude Y scale, 158
 - reference position, 159
 - reference value, 158
 - scale coupling, 159
 - scale per division, 158
 - iDEN
 - ACP measurement, 270, 275, 276, 286, 287
 - iDEN offset frequencies, 271
 - iDEN trigger source, 289
 - IF BW key, 145
 - IF filter
 - gain setup, 123, 145
 - setup, 145
 - type, 145
 - IF Flat Corr key, 124, 146
 - IF Flatness
 - advanced spectrum feature, 129
 - IF path filter
 - alpha, 123, 145
 - bandwidth, 123, 145
 - setup, 123
 - type, 123
 - IF Path key, 127, 148
 - IF setup, 123, 145
 - IF trigger delay, 338
 - IF trigger level, 338
 - IF trigger slope, 339
 - initial signal connection, 36
 - initiate measurement, 207, 208
 - input
 - external attenuator, 95
 - attenuation for BTS tests, 95
 - attenuation for MS tests, 95
 - IF alignment signal, 95
 - signal amplitude, 95
 - signal rate, 95
 - signal type, 95
 - input attenuator, 95
 - input port, 94
 - 50 MHz reference, 94
 - rf, 94
 - maximum total power, 94
 - RF input range, 94
 - input attenuation, 305
 - input port
 - 50 MHz reference, 94
 - IF align, 94
 - input port selection, 304
 - input power
 - maximum, 305
 - range, 305
 - Install Now key, 26
 - Installing and Obtaining a license key, 25
 - installing measurement personalities, 21
 - instrument configuration, 209
 - internal reference selection, 304
 - IQ port selection, 304
 - IS-95A, 307, 308
 - IS-95B, 307, 308
 - IS-95C, 307, 308
- J**
- JSTD8, 307, 308
- L**
- Length Ctrl key, 124, 128
 - Length key, 125, 128
 - license key
 - obtaining and installing, 25
 - limit line testing, 169, 217
 - limit testing
 - ACP, 168
 - NADC, 168
 - PDC, 168
 - linear envelope view
 - linear envelope window, 157
 - phase window, 158
 - linear envelope window, 155
 - amplitude Y scale, 157
 - reference position, 157
 - reference value, 157
 - scale coupling, 158
 - scale per division, 157
 - linear spectrum window
 - amplitude Y scale
 - reference position, 138
 - reference value, 138
 - scale coupling, 138
 - scale per division, 138
 - span, 137
 - loading an application/personality, 21
- M**
- major functional keys, 33
 - making measurements, 213
 - markers, 181
 - assigning them to traces, 186
 - maximum, 184
 - minimum, 185
 - off, 186
 - trace assignment, 190, 191
 - turn off, 184
 - type, 185
 - valid measurement, 181
 - value, 191
 - value of, 184
 - x-axis location, 190, 191
 - y-axis, 191
 - maximum value of trace data, 179
 - mean value of trace data, 179
 - Meas Time key, 144
 - MEASure command use, 213
 - MEASure commands, 214
 - measure setup
 - restore measurement defaults, 104, 109, 127, 148
 - measurement
 - adjacent channel power, 265
 - adjacent channel power ratio, 265
 - channel power, 108, 295, 344
 - close spurs, 301
 - code domain power, 292
 - markers, 181
 - modulation accuracy (rho), 308
 - query current, 193
 - spectrum (frequency domain), 312
 - waveform (time domain), 326
 - measurement modes
 - currently available, 209
 - selecting, 209, 211
 - measurement reference type
 - spectral power density
 - reference, 104
 - total power reference, 104
 - measurement setup
 - advanced menu, 109
 - averaging mode, 100, 108, 125, 146
 - exponential, 100, 108, 125, 146
 - averaging number, 100, 108, 125, 146
 - averaging type, 125, 147

- log power average (video), 126, 147
- maximum voltage average, 126, 147
- minimum voltage average, 126, 147
- power average (rms), 125, 147
- voltage average, 126, 147
- channel power span, 108
- integration bandwidth, 108
- time averaging number, 126, 147
- measurements
 - adjacent channel power ratio, 218
 - channel power, 242
 - close spurs, 243
 - code domain power, 226
 - CONF/FETC/MEAS/READ commands, 213
 - control of, 207
 - getting results, 213
 - modulation accuracy, 244
 - query current, 217
 - setting default values remotely, 215
 - single/continuous, 207
 - spectrum (frequency domain), 259
 - waveform (time domain), 262
- measuring I/Q data, 259, 262
- measuring in the time domain, 87
- Min Pts in RBW key, 124, 128
- minimum value of trace data, 179
- missing options, 21
- mobile station
 - loss correction, 300
- mobile station testing, 307
- modulation accuracy (composite rho)
 - correlated power, 345
 - modulation quality, 345
 - rho, 345
- modulation accuracy (rho)
 - measurement, 308
- See also RHO
- modulation accuracy measurement, 244
- N**
- NADC
 - offset frequencies, 271
 - trigger source, 289
- NADC measurement, 265
- normal marker, 185
- O**
- offset frequencies, 284
 - ACP, 271
- Option 122 wideband selection, 127, 148
- options
 - loading/deleting, 21
- options not in instrument
 - memory, 21
- P**
- packing
 - SPECTrum, 312
- pass/fail test, 169, 217
- PDC
 - offset frequencies, 271
 - trigger source, 289
- PDC measurement, 265
- personalities
 - currently available, 209
 - selecting, 209, 211
- personality options not in instrument, 21
- phase graph
 - amplitude Y scale, 116
- phase inversion, 293
- phase window, 155
 - amplitude Y scale, 158
 - reference position, 158
 - reference value, 158
 - scale per division, 158
- PKOR, 307, 308
- PN offset number setting, 294
- points/measurement
 - CHPower, 297
- pre-ADC bandpass filter
 - SPECTrum, 317
- Pre-ADC BPF key
 - spectrum measurement, 127
- pre-FFT bandwidth, SPECTrum, 316, 317, 318
- Pre-FFT BW key, 127
- Pre-FFT Fltr key, 127
- preset, 36
 - factory defaults, 36
- preset states, 36, 93
- procedure
 - using the waveform measurement, 87
- programming
 - compatibility among PSA modes, 163, 165
 - compatibility, PSA series versus VSA, 166
- PSA series versus VSA (programming compatibility), 166
- Q**
- Q origin
 - I/Q Polar window, 155, 159
 - I/Q polar window, 156, 159
- Q Origin key, 138, 139
- Q waveform window
 - amplitude Y scale, 158
 - reference position, 159
 - reference value, 158
 - scale coupling, 159
 - scale per division, 158
- query data, 169, 179
- R**
- Raised Cosine Key, 123, 145
- READ command use, 213
- READ commands, 216
- real number data format, 205
- rear panel external trigger
 - delay, 335
 - slope, 336
- reference, selecting internal, 304
- Res BW key
 - spectrum measurement, 123
 - waveform measurement, 145
- restart measurement, 208
- results, waveform measurement, 352
- return data, 169, 179
- RF input, selection, 304
- RHO
 - spectrum type, 310
 - sweep time, 310
- RMS of trace data, 179
- Root Nyquist key, 123, 145
- RRC (root raised cosine) key, 123, 145
- S**
- Sample Rate key, 145
- sampling trace data, 179
- selecting the
 - wideband/narrowband path, 127, 148
- set up the wideband IF, 123, 145
- signal envelope view
 - signal envelope window, 157
- signal envelope window, 155
 - amplitude Y scale, 157
 - reference position, 157
 - reference value, 157
 - scale coupling, 157
 - scale per division, 157
- single vs. continuous
 - measurement mode, 207
- span

- CHPower, 297
- selecting IF path, 127, 148
- SPECTrum, 323
- Span key
 - spectrum measurement, 123
- SPECTrum
 - acquisition packing, 312
 - ADC range, 313
 - data decimation, 319
 - FFT length, 320
 - FFT resolution BW, 321
 - FFT window, 322
 - FFT window delay, 321
 - frequency span, 323
 - sweep time, 323, 324
 - trigger source, 324
- spectrum
 - all traces, 137, 155
 - averaged trace, 137, 155
 - changing views, 65, 132
 - current trace, 137, 155
 - I signal trace, 137, 155
 - next window selection, 132
 - Q signal trace, 137, 155
 - span X scale, 137
 - trace display, 137, 155
 - view/trace, 65, 132
 - zoom a window, 132
- Spectrum (Frequency Domain)
 - key, 123, 351
- spectrum (frequency domain)
 - measurement, 259, 312
 - See also SPECTrum
- spectrum measurement
 - basic mode, 89
 - method, 351
 - results, 63, 132
- spectrum measurement display, 195, 196, 202, 203
- spectrum phase
 - CDPower, 293
- spectrum type
 - RHO, 310
- spur close
 - amplitude Y scale, 60, 143
 - reference position, 60, 143
 - reference value, 60, 143
 - scale coupling, 60, 143
 - scale per division, 60, 143
 - using markers, 60, 144
- standard deviation of trace data, 179
- standard, selecting for CDMA, 307, 308
- start measurement, 207, 208
- state
 - changing, 265
- sweep time
 - CDPower, 294
 - RHO, 310
 - SPECTrum, 323, 324
 - WAVEform, 332
- Sweep Time key, 144
- synchronization
 - CDMA, 325
- T**
- test limits, 169, 217
 - NADC, 168
 - PDC, 168
- threshold value, CDPower, 293
- tile the display, 194
- time averaging, 126, 147
- time domain measurement, 262, 326
- time domain measurements, 144, 352
- trace data
 - processing, 179
- trace display, 197
- trace format, 205
- trace names for markers, 186
- trace/view selection
 - magnitude & phase graph view, 80, 153
- transmit band spurs - averaging
 - state, 291, 328
- trigger, 96
 - auto time, 334
 - automatic trigger, 97
 - burst level, 339
 - commands, 334
 - delay, 96, 335
 - delay, IF, 338
 - external, 335, 336
 - external front input, 96
 - external rear input, 96
 - frame adjustment, 336, 337
 - frame period, 336
 - frame sync mode, 337
 - frame timer, 97
 - offset, 97
 - period, 97
 - reset offset display, 97
 - synchronizing source, 97
 - holdoff, 338
 - level, 96, 335
 - level, IF, 338
 - on/off, 334
 - RF burst signal, 96
 - slope, 97, 336
 - slope, IF, 339
 - SPECTrum, 324
 - timeout, 334
- trigger holdoff, 97
- trigger source, 126, 147
 - external front input, 126, 148
 - external rear input, 127, 148
 - frame clock, 127, 148
 - free run (immediate), 126, 147
 - line, 127, 148
 - RF burst (wideband), 126, 148
 - video (IF envelope), 126, 148
 - video (envelope) signal, 96
 - WAVEform, 333
- trigger measurement, 207, 208
- trigger source
 - ACP, 289
 - Rho, 310
- triggering
 - CHPower, 299
- triggering setup help, waveform measurement, 87
- U**
- Uninstall Now, 28
- uninstalling measurement
 - personalities, 21
- V**
- view ACP data, 194
- view commands, 194
- view/trace
 - I/Q waveforms, 66, 134
 - linear spectrum and phase graphs, 66, 134
 - spectrum graph, 65, 132
- view/trace selection
 - I and Q Waveform view, 154
 - I and Q waveform view, 139
 - I/Q polar waveform view, 82, 154
 - I/Q waveform graph window, 65, 133
 - I/Q Waveform view, 81, 153
 - linear envelope and phase view, 80, 152
 - Spectrum I/Q Waveform view, 65, 133
 - spectrum linear
 - linear spectrum window, 137, 138
- viewing the time domain, 87
- VSA versus PSA series
 - (programming compatibility), 166
- W**
- WAVEform
 - acquisition packing, 326

Index

- ADC dithering, [326](#)
 - ADC filter, [326](#)
 - ADC range, [327](#)
 - data decimation, [331](#), [332](#)
 - sweep time, [332](#)
 - trigger source, [333](#)
 - waveform
 - changing displays, [155](#)
 - I and Q waveform view, [158](#)
 - I/Q waveform view, [158](#)
 - linear envelope view, [158](#)
 - method, [352](#)
 - resolution bandwidth, [145](#)
 - results, [78](#)
 - span X scale, [155](#)
 - sweep time, [155](#)
 - using markers, [159](#)
 - Waveform (Time Domain) key, [352](#)
 - Waveform (Time Domain) Key Menus, [144](#)
 - waveform (time domain)
 - measurement, [262](#), [326](#)
 - See also WAVEform
 - waveform measurement, [87](#), [144](#)
 - basic mode, [89](#)
 - display, [159](#)
 - I/Q Polar view, [155](#), [159](#)
 - results, [78](#)
 - WB ADC Dither key, [124](#), [146](#)
 - W-CDMA
 - ACP measurement, [270](#), [275](#), [276](#), [286](#), [287](#)
 - trigger source, [310](#)
 - W-CDMA (3GPP) measurement, [218](#), [226](#), [244](#)
 - W-CDMA (Trial & ARIB)
 - measurement, [218](#), [226](#), [244](#)
 - W-CDMA measurement, [265](#)
 - Wideband Advanced key, [123](#), [145](#)
 - wideband filter alpha, [123](#), [145](#)
 - wideband filter bandwidth, [123](#), [145](#)
 - wideband filter type, [145](#)
 - Wideband Filtering key, [123](#), [145](#)
 - wideband IF
 - advanced settings, [124](#), [145](#), [146](#)
 - wideband IF data block size, [145](#)
 - wideband IF data sample rate, [145](#)
 - wideband IF filter type, [123](#)
 - Wideband IF Gain key, [123](#), [145](#)
 - Wideband IF Setup key, [123](#), [145](#)
 - wideband path selection, [127](#), [148](#)
 - Window Length key, [125](#), [128](#)
- Z**
- zero span measurement, [262](#), [326](#)
 - zoom the display, [195](#)